



2010  
WATER  
SPECIFICATIONS

# **TABLE OF CONTENTS**

## **INTRODUCTION**

### **SECTION 100 - GENERAL INFORMATION**

**Page**

101.	General Requirements - Use of this Document	100-1
102.	Approval By Other Government Agencies	100-2
103.	List of Commonly Used Terms	100-2
104.	List of Acronyms	100-3
105.	Appeals	100-4
106.	Insurance Requirements (3 <sup>rd</sup> Party)	100-4

---

### **SECTION 200 - PLANS**

201.	Water Pressure Flow Test	200-1
202.	Preliminary Plan Requirements	200-2
203.	Construction Plans	200-2
204.	Erosion and Sedimentation Control Plan	200-8
205.	Plan Approval	200-9
206.	Revisions to Approved Plans	200-9
207.	Approval By Other Government Agencies	200-9
208.	Relocation of Existing Water and Sewer Infrastructure	200-10
209.	Easement Acquisition and Utility Encroachment Permits	200-10

---

### **SECTION 300 - DESIGN CRITERIA**

301.	General	300-1
302.	Water Supply (All Water Supply Systems)	300-1
303.	Water Main Extension Requirements	300-2
304.	Minimum Water Main Sizes	300-2
305.	Water Main Sizes	300-3
306.	Fire Protection	300-3
307.	Sprinkler Systems	300-5
308.	Disconnection of Wells	300-5
309.	Location of Water Lines and Fixtures	300-5
310.	Fire Line Metering Requirements	300-10
311.	Water Pump Stations	300-12
312.	Water Mains on Private Roads	300-12
313.	Separation Between Water Main and Sanitary Sewer Mains	300-13

---

### **SECTION 400 - MATERIALS FOR WATER LINE CONSTRUCTION**

401.	General	400-1
402.	Water Main	400-1
403.	Fire Hydrants	400-2
404.	Valves and Accessories	400-3
405.	General Requirements	400-10

---

## **SECTION 500 - CONSTRUCTION METHODS**

501.	Excavation General	500-1
502.	Erosion and Sedimentation Control	500-1
503.	Clearing and Grubbing	500-2
504.	Trench Excavation	500-2
505.	Rock Excavation	500-5
506.	Subgrade and Bedding	500-6
507.	Installation of Water Main	500-7
508.	Backfilling Trenches	500-9
509.	Thrust Restraint for Pressure Lines	500-10
510.	Setting Fire Hydrants	500-11
511.	Setting Valves and Fittings	500-12
512.	Marking Location of Valves and The End of The Main	500-13
513.	Placing of Steel Casing Pipe	500-13
514.	Connection to the Existing Authority Water System	500-14
515.	Interruption of Water Supply During Construction	500-14
516.	Railroad Crossings	500-15
517.	Highway Crossings	500-15
518.	Stream Crossings	500-16
519.	Replacement of Pavement	500-17
520.	Location and Protection of Existing Underground Utilities	500-19
521.	Clean-Up	500-19
522.	Grassing	500-20
523.	Standard Detailed Drawings	500-21
525.	Barricades	500-21
526.	Fences	500-21
527.	Rip-Rap	500-21

---

## **SECTION 600 - INSPECTION, TESTING AND ACCEPTANCE**

601.	Inspection	600-1
602.	Water System Testing	600-2
603.	Acceptance	600-6
604.	"As-Built" Record Drawings	600-7

---

## **SECTION 700 – CROSS-CONNECTION CONTROL PROGRAM**

Cross-Connection Control Program

---

## SECTION 800 - STANDARD DETAILS

	<b><u>STANDARD DETAIL NO.</u></b>
Typical Water Main At Cul-De-Sac	W701
Typical Fire Hydrant Installation	W702
3/4" Water Meter Location (For Subdivisions)	W703
Residential Water Meter Installation	W704
Meter Box For 5/8" or 1" Meter	W705
Standard Jumbo Cast Iron Meter Box	W706
House Service Installation	W707
Detector/Water Meters and Vault	W710
Water A&V Release Valve Assembly	W711
Typical Road Crossing	W712
Concrete Blocking for Bends	W713
Concrete Blocking for Tees and Plugs	W714
Concrete Blocking - Vertical Bends - Upward Thrust	W715
Concrete Blocking - Vertical Bends - Downward Thrust	W716
Concrete Thrust Collar	W717
Typical Valve Installation	W718
Concrete Valve Marker	W719
Blow-Off Assembly	W720
Typical Street Cut Repair	W721
Typical Driveway Cut Repair	W722
Turn Lane Relocation Detail	W723
Water Line Maintenance Sign	W724
New Project Plan Approval Sheet	W725
Utility Placement Detail With Curb	W726A
Utility Placement Detail Without Curb	W726B
New Project Requirement Detail	W727
Sample Certificate of Liability Insurance	W728
"Call Before You Dig" Detail	W729
General Notes for Water Main Construction	W730
Sample Easement for Water Main	W731

# SECTION 100 - GENERAL INFORMATION

## 101. GENERAL REQUIREMENTS - USE OF THIS DOCUMENT

- 1.) This document is subject to periodic revision to meet changing requirements for materials, fire and safety regulations, environmental regulations, etc. At the beginning of a project, users should verify that they have the latest edition.
- 2.) This document is intended to convey the general design and construction requirements for a typical project. It also lists specific Cherokee County Water and Sewerage Authority requirements relating to plan review, inspection, testing and acceptance of facilities. It is not intended as a substitute for site-specific engineering and construction techniques. Individual project conditions may require variances from the provisions in this document in which case such variances should be noted in the plans and other data submitted by the project design professional for the Authority's approval.
- 3.) The Standard Details in **Section 800** are complementary to the Specifications written herein. If the developer or designer notes any discrepancies or desires an interpretation of a specification, they should submit their question to the Authority in writing for a decision by the Authority or the Authority's representative.
- 4.) Failure by the Authority or the Authority's plan review representative to notice any deviations from the Authority's Standards during the plan review process does not alleviate the Developer's responsibility to adhere to the Standards.
- 5.) The Developer must submit six (6) paper copies of Construction Plans, plus the electronic data on disc, as outlined in these specifications, to the Authority for review.
- 6.) An approved set of construction plans stamped by the Authority must be kept onsite at all times by the Contractor.
- 7.) The Authority shall be notified by the Developer or his contractor before construction begins, and at the various stages in construction as required by the Authority. The Authority shall be given a minimum of 4 days advance notice before an inspection is needed. **See Section 515 regarding notifying the public about interruption of the water supply during construction.**

- 8.) Contractors performing utility construction must be licensed in accordance with State of Georgia law and local ordinances and approved by the Authority. They shall maintain liability insurance to the minimum requirements of the Authority. **(See Detail W727 for a sample of the Certificate of Liability Insurance to be submitted.)** They should be completely familiar with the procedures and contract requirements associated with this type of project. Unsatisfactory work will cause a contractor to not be approved for future work.
- 9.) The Developer is responsible for replacing any and all water and/or sewer facilities which are damaged by the Developer and any of his Contractors and any Builder working at the project site. Water and sewer facilities include but are not limited to service lines, meters, meter boxes, valves, valve boxes, valve markers, fire hydrants, and manholes.

## **102. APPROVAL BY OTHER GOVERNMENT AGENCIES**

No part of the approval process is intended to relieve the Developer of the responsibility to comply with minimum standards of the Cherokee County Water & Sewerage Authority, Georgia Department of Natural Resources, E.P.A., E.P.D., N.R.C.S., Georgia Department of Transportation, Cherokee County Engineering Department, U.S. Army Corps of Engineers or other appropriate regulatory agency.

## **103. LIST OF COMMONLY USED TERMS**

"Authority" shall mean the Cherokee County Water and Sewerage Authority.

"Contractor" shall mean the individual, firm or corporation undertaking the execution of the Work under the terms of the contract and acting through its agents and employees.

"Developer" shall mean the individual, firm or corporation financing the execution of the Work.

"Engineer" shall refer to the engineer appointed by the Authority as representatives of the Authority and to its properly authorized agents.

"General Manager" shall refer to the General Manager of the Cherokee County Water and Sewerage Authority.

"Chief Inspector" shall refer to the Chief Inspector of the Cherokee County Water and Sewerage Authority.

"Owner" shall refer to the Cherokee County Water and Sewerage Authority.

"Plans" shall refer to those drawings that show the character and scope of the work and shall include all drawings identified in the contract documents.

"Shall" and "Will" are mandatory; "May" is permissive.

"Specifications" and "Standards" shall refer to the Water Main Standards of the Cherokee County Water and Sewerage Authority.

"Work" of the contractor shall include all labor, material, equipment, skills, transportation, tools, machinery, and other equipment and things useful and necessary to complete the contract.

#### **104. LIST OF ACRONYMS**

ASTM: American Society for Testing and Materials

AWWA: American Water Works Association

DIP. Ductile Iron Pipe

DOT: Georgia Department of Transportation

EPA: United States Environmental Protection Agency

EPD: Georgia Department of Natural Resources, Environmental Protection Division

CCWSA: Cherokee County Water and Sewerage Authority

HDPE: High Density Polyethylene

NRCS: National Resource Conservation Service

OSHA: United States Dept. of Labor, Occupational Safety and Health Administration

PVC: Polyvinyl Chloride

RCP: Reinforced Concrete Pipe

VCP: Vitrified Clay Pipe

## **105. APPEALS**

Any requirement that is outlined in these specifications may be modified or revoked by a majority vote of the full membership of the Cherokee County Water and Sewerage Authority.

Persons wishing to file an appeal must submit a written request to the Authority prior to the Agenda date for the next Authority meeting stating the nature of the request to be made. If the request is not made prior to the Agenda date, it will be considered at the following regularly scheduled meeting of the Authority. Please contact the Authority's office for information regarding the deadline date to be included on the agenda.

## **106. INSURANCE REQUIREMENTS**

### **Cherokee County Water And Sewerage Authority**

**3<sup>rd</sup> Party Contractor Hold-Harmless Agreement,  
Insurance, Indemnity, and Additional Insured**

---

#### **3<sup>rd</sup> Party Contractor**

Contractor's Liability Insurance: Contractor shall maintain at its sole cost and expense such insurance as will fully protect it and Cherokee County Water And Sewerage Authority (et al), CCWSA's officials, directors, officers, employees, agents, and volunteers from incidents, accidents, and claims for bodily injury and property damage which may arise from operations under this Contract; whether such operations are performed by Contractor or by any Subcontractor directly employed or retained by either.

#### **INDEMNITY AND INSURANCE**

##### **Commercial Insurance**

1. Workers' Compensation Insurance in compliance with the applicable Workers' Compensation Act(s) of the state(s) wherein the work is to be performed or where jurisdiction could apply in amounts required by statutes.
2. Employer's Liability Insurance, with limits of liability of not less than \$1,000,000 for each accident/disease.



3. General Liability Insurance, including contractual liability insurance, explosion and underground collapse (XCU), product and completed operations, personal and advertising injury, damage to rented premises (each occurrence \$100,000), medical expense (any one person \$5,000), fire damage (\$50,000), and any other type of liability for which this Contract applies with limits of liability of not less than \$1,000,000 each occurrence / \$1,000,000 annual aggregate. General Liability Insurance must be written on an “occurrence” form and must apply on at least a per “project” basis.

#### Property Insurance

The Contractor assumes sole responsibility for loss or damage to its property and hereby releases CCWSA and its officials, directors, officers, employees, agents, and volunteers from loss or damage to Contractor and its employee’s tools, equipment, goods, machinery, materials, and supplies.

#### Conditions

The aforementioned insurance policies shall contain a provision that coverages afforded under such policies shall not expire, be canceled or altered without at least thirty (30) days prior written notice to CCWSA’s Risk Management Department. Except for insurance coverages relating to Workers’ Compensation and Employer’s Liability, the foregoing insurance policies shall include an endorsement making Cherokee County Water And Sewerage Authority an Additional Insured under such policies and a clause that insurance is on a primary and non-contributory basis. A copy of the endorsement and clause are to be provided to CCWSA’s Risk Management Department. Certificates of Insurance showing that such coverages are in force shall be filed under this Contract by the Contractor.

The Certificate(s) of Insurance shall also contain a statement as follows:

“This/These certificate(s) of insurance conform(s) to all terms and conditions (including coverage of the indemnity agreement) contained in Contract with Cherokee County Water And Sewerage Authority.”

Such certificates and notices are to be sent to:

**Cherokee County Water And Sewerage Authority  
Attn: Risk Management Department  
391 West Main Street  
Canton, GA 30114**

with a copy to:

**Cherokee County Water And Sewerage Authority  
Attn: Special Projects Department  
583 Cokers Chapel Road  
Ball Ground, GA 30107**

Non-Limitation on Contractor's Liability

The obligations for Contractor to procure and maintain insurance shall not be construed to waive or restrict other obligations and it is understood that insurance in no way limits liability of the Contractor or limits the liability of Contractor whether or not same is covered by insurance.

The Contractor further understands and agrees that any damages, that the Cherokee County Water And Sewerage Authority deems to be a result of said contract work, whether made directly by the Contractor or a Subcontractor thereof, is the sole responsibility of the Contractor and will be repaired, replaced, or recompensed according to specifications in place at the time of discovery.

Insurance Form and Duration

All of the insurance herein specified shall be written on a form acceptable to CCWSA and shall be A.M. Best Company rated B+ 8 or better.

Indemnity

The Contractor agrees to protect, defend, indemnify, save and hold harmless Cherokee County Water And Sewerage Authority, its officials, directors, officers, employees, agents, and volunteers from and against any and all claims, demands, losses, costs, and expenses, and from and against all liability, awards, judgments, and decrees, of whatever nature for any and all damage to property of others and of the parties hereto, their officials, directors, officers, employees, agents, and volunteers, and of whatever nature for any and all injury or injuries (including death) to any person or persons including the officials, directors, agents, employees, agents, and volunteers of the party hereto, arising or in any way growing out of any of the acts or omissions whether of the Contractor, the Contractor's officials, directors, officers, employees, agents, and volunteers or of any tier of the Subcontractor, the tier's officials, officers, directors, employees, agents, and volunteers in connection with the performance of the work under this Contract.

This hold-harmless agreement must be signed and submitted to the CCWSA's Risk Management Department prior to commencement of work.

\_\_\_\_\_  
Contractor

Date

\_\_\_\_\_  
CCWSA Representative

Date

## SECTION 200 - PLANS

### 201. WATER PRESSURE FLOW TEST

- 1.) Flow test are required for rezoning and prior to submittal of construction plans, the flow test results will be considered valid for twelve (12) months from the date of the test. To schedule a flow test, contact the Special Projects Coordinator at (770) 479-1813 Ext. 249.
- 2.) Water pressure flow test must be run on any existing Authority water line to determine the adequacy of water supply for the project. The test shall consist of fire hydrant flow test and a twenty-four (24) hour pressure test.

Test information shall consist of:

- A.) Static Pressure and Elevation of Static Gauge
- B.) Recorded Flow in GPM and Residual Pressure
- C.) Maximum Elevation in Development
- D.) Available Flow at Maximum Elevation with 20 PSI Residual Pressure
- E.) Twenty-four (24) hour pressure chart

An adequate supply of water for the proposed project must be available prior to the approval of any construction plans unless an exception is granted by the Authority.

- 3.) All projects which have flow test / pressure chart test results showing static pressures of less than 35 psi will require a special design study to be completed and submitted to the Authority for approval to insure that no problems will be encountered during peak demand periods. This study must be approved by the Authority before any construction plans will be approved.
- 4.) Flow and pressure tests will be conducted by the Authority or a representative of the Authority in the area of the proposed development. These tests shall be paid for by the Developer prior to the performance of tests at the rate then in effect as established by the Authority. This fee shall be paid by the Developer along with the initial submittal of preliminary plans as described above. Plans shall not be stamped or approved until the flow test is completed.

## **202. PRELIMINARY PLAN REQUIREMENTS**

### **Preliminary Plans**

- 1.) Preliminary plans shall include the portion of the county tax maps highlighting the land to be developed, the type of development, the number of units, the tie-in location and the general plan for water supply. The plans shall also include the name, address and telephone number of the Developer or his representative. Questions relating to adequate fire protection, multiple feeds, water supply and proposed location of connection(s) should be resolved at this stage before proceeding with detailed planning. The submittal for preliminary review must include all land to be developed although the land is to be developed in several phases or units. Adequacy determinations of the existing water supply system will be made for the entire project.
- 2.) Developer/Land Owner must submit a set of preliminary plans for any proposed project to the **Special Projects Coordinator** prior to submitting the construction plans.

## **203. CONSTRUCTION PLANS**

- 1.) The Developer must then submit six (6) paper copies of Construction Plans, plus the electronic data on disc, as outlined in these specifications, to the Authority for review. Plans and other submittals shall be delivered to the Authority's G.P.S. Department. Construction plans must be submitted to the Authority's G.P.S. Department for review and comments. All plans for water main projects shall bear a suitable title showing the name of the project. Plans shall show the scale in feet, the north arrow, date, the name of the design professional, the design professional's signature and his registration stamp. All design professionals preparing construction plans and specifications must be registered in the State of Georgia as a professional engineer or a registered land surveyor. If the project requires a water line extension of more than 500 feet to reach the project, a registered professional engineer must design and stamp the line extension. The cover sheet shall include the Owner's/Developer's name, address, telephone number, and fax number, plus the design professional's name, address, telephone number, and fax number. The cover sheet shall also include the funding source if state or federally funded, and a detailed project location map. The cover sheet shall also show the numbers of the tax map and parcel in bold letters.

The plans shall be clear and legible. They shall be drawn to a scale which will permit all necessary information to be plainly shown. Plans shall be submitted on 22" x 34" drawing sheets and shall be submitted concurrently in an "Autocad" drawing electronic format. A sheet index shall be provided, as well as a legend of symbols used.

Horizontal locations shall be referenced to Georgia State Plane Coordinates (West Zone feet). Vertical locations shall be shown referenced to Mean Sea Level. Reference all horizontal locations to the NAD83/94 (latest adjustment) datum and reference all vertical locations to the NAVD88 datum. All orthometric locations shall be referenced to Geoid 99/03. All points are subject to verification by the Cherokee County Water & Sewerage Authority. Water line locations shall be shown on plans and submitted in ASCII

Text or EXCEL electronic format for each point. The Developer shall provide ASCII or EXCEL spread sheet files for coordinate data. (comma delimited). Each Point I.D. (Valves, Water Main, etc...) shall be show at the correct location on the printed plans. Water Mains along County or State Roads and cross country shall be located at 50' intervals (ground and top of pipe). If Water Main is within the development and maintains a constant distance behind curb and constant depth, locate at all transitions (vertical and horizontal). All fittings, tees and bends, valves, and air release valves shall also be located. All vertical locations shall be finished ground and top of pipe. The Contractor shall place a vertical piece of 2" diameter P.V.C. pipe on top of the pipe at all bends, tees, fittings, valves, elevation transitions, horizontal transitions and every 50' along the length of the water main (County or State Roads and cross country) for the purpose of enabling the surveyor/engineer to locate the water main for "As-Builts". The Contractor will then be responsible for removing the vertical P.V.C. sections after the as-built locations have been verified by the Authority. The ground, top of pipe, top of fitting and top of valve elevation of shall be located. The size and material of all pipes, valves and fittings shall be recorded. All electronic point data shall include

- a.) Point ID (see CCWSA staff)
- b.) Northing
- c.) Easting
- d.) Ground Elevation
- e.) Top of Pipe, Valve or Hydrant Elevation
- f.) Point Description (Pipe, Fitting or Valve Type and Size)

Construction Plans shall consist of the following:

- A.) Site plan showing the water layout only with project name, streets, street names, topography with contour lines at two foot intervals, location map, lot layout (if subdivision) or building location (multi-family, commercial or industrial site), land lots, district and north arrow. Lot numbers shall run in consecutive order and there shall be no duplicate lot numbers within the project. Note if any other utilities are existing. Plan scale shall be a minimum of 1"=100'. Both the Construction Plans and "As-Builts" shall show station numbers along the alignment plus call out the specific stations of all features such as tees, crosses, fire hydrants, bends, etc. along with the Point I.D. Match lines shall be provided where necessary.
- B.) Proposed pipe materials, sizes, lengths and alignment.

- C.) Proposed service lateral locations.
- D.) Location, type and size of water valves and air release valves (to be installed at highest points of system).
- E.) Thrust blocks where used.
- F.) Fire hydrant locations.
- G.) Water system materials.
- H.) Location and sizes of existing water lines surrounding project, with nearest line valve in each direction from proposed connection.
- I.) Detail of connection to existing water lines.
- J.) Proposed meter sizes and locations.
- K.) Detailed plan of fire line meters, detector meters, compound meters, backflow preventers, etc. if applicable.
- L.) Any other items incidental to the proposed system.
- M.) Details of special water line installations such as stream crossings, elevated lines on piers, bridges, pipe bedding, special highway crossings, railroad crossings, etc.
- N.) Show all right-of-way widths, easement widths and pavement widths.
- O.) Plan and profile sheets shall be prepared with a horizontal scale of 1"=50' and a vertical scale of 1"=10'. These scales also apply to any profile view of sanitary sewers.
- P.) Bench marks and control points shall be shown on the plan sheets. Horizontal and vertical coordinate data shall be provided for each bench mark and control point. The vertical datum used shall be the elevation above mean sea level.
- Q.) A sheet index shall be provided, as well as a legend of symbols used.
- R.) Each plan sheet should include a note stating "The Contractor must call the Utilities Protection Center "Call Before You Dig" telephone number (1-800-282-7411) four days before starting any excavation.
- S.) All construction plans submitted for review of revisions requested by the Authority must list each revised item with a cloud around the revised area on the plan sheet and must identify which reviewing authority requested the revision.
- T.) Each set of construction plans shall include a reproduction of the following information (**Detail W725**) from the Utilities Protection Center:

**DETAIL W725**

**COLOR CODES  
FOR  
UTILITY LOCATING**

**RED**      ELECTRIC

**YELLOW**      GAS-OIL

**ORANGE**      TELEPHONE/CATV

**BLUE**      WATER

**GREEN**      SEWER

**IF YOU DIG GEORGIA**

**CALL US FIRST !**

1-800-282-7411

*It's The Law !*

**Utilities Protection Center, Inc.**

**THREE WORKING DAYS  
BEFORE  
YOU DIG GEORGIA  
CALL**

**Utilities Protection  
Center, Inc.**



**1-800-282-7411**

***It's The Law !***

The General Notes for Water System Construction shown on the following pages (**Detail W726**) shall be included in each set of plans.

## **DETAIL W730 – PAGE 1 of 3**

### CHEROKEE COUNTY WATER AND SEWERAGE AUTHORITY POTABLE WATER SYSTEM CONSTRUCTION GENERAL NOTES

1. All potable water system construction must follow the current Cherokee County Water and Sewerage Authority Water Main Standards.
2. All water mains shall be ductile iron pipe, except where the Construction Manager approves otherwise. Ductile iron pipe shall be thickness Class 50, designed in accordance with AWWA C150 and manufactured in accordance with AWWA C151. All ductile iron pipe shall have an outside bituminous coating per AWWA C151 and an inside standard cement lining with bituminous seal coat per AWWA C104. All references to AWWA standards shall mean latest revisions published.
3. All line valves shall be marked by concrete valve markers and by a "V" cut into the curbing, with the point of the "V" aimed at the valve.
4. A concrete valve marker is to be placed directly above the plug on all dead-end water mains.
5. Information regarding underground utilities on these plans is not guaranteed as to accuracy or completeness. Prior to beginning work, the Contractor shall request a field location through the utilities protection center and any utility owners thought to have facilities in the area. The Contractor shall promptly compare these field-marked locations with the project plans and then notify the Designer of any anticipated problems or need for contract changes. It is the Contractor's responsibility to excavate or cause the utility owner to excavate for the purpose of determining exact elevations or locations at utility crossings and other critical locations well in advance of the work under this contract. Damage to existing utilities resulting from the Contractor's negligence shall be repaired at the Contractor's expense.
6. All service lines under pavement shall be encased in Schedule 40 PVC casing with a minimum diameter of 2", extending a minimum of 3 feet beyond the pavement and/or sidewalk on each side of the road. 2" services shall be encased in 4" PVC casings. All water service laterals 2" and smaller shall be Type K copper tubing with compression fittings as specified in the Water Standards.
7. Concrete thrust blocking shall be placed at all bends, tees, valves, reducers and all other fittings. Prior to blocking, fittings shall be wrapped with polyethylene film.
8. The Developer/Contractor shall meet with the Chief Inspector at least 24 hours before beginning construction. The Contractor shall notify the Chief Inspector or his designated representative by 8:30 a.m. of each workday when work is scheduled unless authorized otherwise.
9. Water mains shall be installed so that the top of the pipe is a minimum of four feet below final grade, four feet below the edge of the pavement, or four feet below the ditch paralleling the road, whichever is deepest.
10. Contractor shall place a vertical piece of 2" PVC pipe on top of the water main at all tees, bends, fittings, elevation transitions, and every fifty feet along the length of the main for the purpose of collecting elevation data for record drawings. The top of the 2" PVC shall be capped or taped to prevent dirt and other debris from clogging the 2" pipe before the depth can be measured.
11. All fittings and valves are to be mechanical joint with retainer glands unless otherwise approved. Retainer glands shall be EBAA Mega-Lug or approved equal.



## **DETAIL W730 – PAGE 2 of 3**

12. Type 4 bedding is required at all restrained pipe installations.
13. Contractor must show proof of insurance in the amount specified by the CCWSA.
14. All backflow preventer devices are to be tested by a CCWSA approved tester. A list of testers is available from the CCWSA. Any tester not on the list is subject to approval by the CCWSA. Contact Mr. Greg Long with the CCWSA for more information.
15. All meters, backflow preventers and double detector check valve assemblies are to be purchased from the CCWSA.
16. A horizontal separation of at least 10 feet is required between existing or proposed water mains and existing or proposed sanitary sewer lines.
17. A vertical separation of at least 18 inches is required where a water main crosses an existing or proposed sanitary sewer line. A full joint of water main is required to be centered at the sanitary sewer line crossing.
18. No portion of this project is being constructed on or near an existing landfill, abandoned landfill, or any other site used for waste disposal.
19. Potable water and sanitary sewer structures are not allowed within a dam. Utility pipelines and structures must be a minimum of 30 feet outside the toe of slope of the dam.
20. Hydrant flow tests are valid for one year and only apply to a single phase of this project.
21. Existing County roads shall not be open cut unless permission is granted by the Cherokee County Department of Public Transportation.
22. Plan approval is valid for 12 months without beginning construction. Plans shall be subject to beginning the process of review and approval if 12 months expire prior to the start of construction.
23. Record drawings of water and sanitary sewer facilities are required to be submitted to the CCWSA upon completion of the project.
24. If construction plans are stamped for a full project, and then the Developer revises the plans to build the development in phases, no construction or field inspection will be allowed to begin until the revised, phased plans are re-approved and stamped for the phased construction.
25. If an existing water main is to be paved over by a new entrance or accel/decel lanes, the water main is to be abandoned and replaced with a new DIP water main located five feet or more behind the new back of curb.
26. New water mains installed along County or State roads, within 80 feet of steel gas main crossings, or in any wetland areas must be encased in polyethylene tubing (Polywrap 8 mil).
27. All streams and protective buffers shall be crossed in accordance with current County and State regulations.
28. Fire hydrants shall be designed to be placed within 200 feet of new entrances, in all cul-de-sacs, and

at every proposed intersection.

**DETAIL W730 – PAGE 3 of 3**

29. New fire hydrants shall be Mueller Super Centurion 250, M&H AWWA C502 Style 129 Traffic Model, or US Pipe Metropolitan 250 Model 94. All hydrants shall be rated for 250 psi working pressure and shall be equipped with a 5¼" valve opening, two 2½" hose nozzles and one 4½" pumper nozzle.
30. Inside of steel casings, pipe joints shall be restrained using Fast-Grip gaskets or approved equal.
31. All new water mains must pass leakage testing and disinfection testing witnessed by a CCWSA representative before a project is released and accepted.
32. All water meter vaults and DDCV assembly vaults are to be located off of the road right-of-way in a permanent easement dedicated to the CCWSA. The easement shall be dimensioned to be 10 feet off each corner of the vault. Smaller domestic use meters adjacent to a DDCV assembly can be located within the 10 foot spacing between the vault and the edge of the easement.
33. Inside of developments with curb and gutter, the Contractor shall cut a "V" into the top of the curb for all water valves (line valves and hydrant valves) with the point of the "V" aimed at the valve. The Contractor shall also cut a "W" in the top of the curb above all water service laterals.
34. The report stating the results of the hydrant flow test and the 24 hour pressure recording chart shall be shown within the plans for this project.

## **204. Erosion and Sedimentation**

- 1.) The provisions of the Erosion and Sedimentation Act of 1975 (O.C.G.A. 12-7-1 et seq.), as amended, shall govern all land disturbing activities as relates to construction performed. The Cherokee County Water & Sewerage Authority is not delegated enforcement powers for enforcing the provisions of the Erosion and Sediment Control Act of 1975.
- 2.) The Georgia Soil and Water Conservation Commission has taken provisions of ACT 599 and published a **MANUAL FOR EROSION AND SEDIMENT CONTROL IN GEORGIA**, 2000 Edition (or any more current edition as they are published). Sewer construction plans and specifications shall include appropriate segments of this manual. Developers, Engineers, Design Professionals and Contractors performing work in Cherokee County are responsible for acquiring a copy and using the best practical methods contained therein to control the erosion and sedimentation of the construction site in conformance with the intent of ACT 599. Copies may be purchased from the Georgia Soil And Water Conservation Commission, P.O. Box 8024, Athens, Georgia 30603. For additional information, call the Commission at 706-542-3065.
- 3.) The erosion control plan must be approved by Cherokee County Engineering and the Natural Resource Conservation Service (N.R.C.S.). As stated in Section 102.5, the approval of the plan included in the N.R.C.S. Report of Technical Review must be attached to the initial submittal of construction plans.

## **205. PLAN APPROVAL**

No work shall begin until plan approval is received from the Authority. The CCWSA General Manager or his designated representative shall have final approval of the preliminary plans, construction plans and final plans. If a discrepancy occurs between the approved plans and the Water Main Standards, the Standards shall be the superseding document. The General Manager of the Authority or his designated representative may modify or cause to be modified any plans that he believes are in the best interest and future integrity of the Authority.

## **206. REVISIONS TO APPROVED PLANS**

- 1.) When any deviations from approved plans are proposed, the Chief Inspector shall be notified for authorization. Revised plans should be submitted as soon as possible to the Chief Inspector. Minor changes not affecting water system operation may be allowed in the field during construction by the Chief Inspector. The Chief Inspector shall have authority as to what constitutes a minor or major change. "As-Built" drawings and the required electronic data on disc shall be furnished to the Authority at the completion of construction.
- 2.) Any section or unit must be built in accordance with the plans. If the Developer decides to phase a section off, a new set of plans showing the phase change will have to be resubmitted and approved.

## **207. APPROVAL BY OTHER GOVERNMENT AGENCIES**

**No part of the plan approval process is intended to relieve the developer of the responsibility to comply with the minimum standards of the Cherokee County Water & Sewerage Authority, Georgia Department of Natural Resources, EPA, EPD, NRCS, Georgia Department of Transportation, Cherokee County, or other appropriate regulatory agency.**

## **208. RELOCATION OF EXISTING WATER AND SEWER FACILITIES**

All existing water or sewer facilities that have to be relocated, as might occur at roadway entrances, easements, elevation changes, etc., will be relocated by the Developer's Contractor at the Developer's expense. The Authority will inspect all such work prior to acceptance.

## **209. EASEMENT ACQUISITION AND UTILITY ENCROACHMENT PERMITS**

- 1.) It shall be the responsibility of the Developer to obtain any off-site easements required to connect the project to the existing water system. Easements will be conveyed to the Cherokee County Water and Sewerage Authority for all facilities which are to be conveyed to the Authority. This process must be started early enough to allow construction of the water mains before any building construction is to begin. No building permits, water meter or sewer tap applications shall be issued until off-site water mains and sewers have been constructed and accepted. This condition shall override any provision for speed up of house starts such as furnishing a bond to guarantee completion of the streets and other appurtenances. A sample water main easement agreement is included at the end of **Section 200**.
- 2.) Easement drawings shall be prepared for work outside the development prior to approval of the water system plans. The drawings shall be of a size suitable for legal recording and shall be prepared by a Registered Land Surveyor. The drawing must be clear and legible for printing. The drawing shall be at a reasonable scale and shall not be a reduced copy of the plan sheet. The drawing will show property lines, the name of property owners with the length of line encroaching on each property owner, size of line, width of permanent and construction easement, scale of drawing, north arrow, land lot and district numbers, and a tie to the nearest land lot corner. Any streets or other existing easements shall also be shown. Easement agreements referencing these drawings shall be prepared and attached to the drawings, signed by the property owners, and recorded at the Cherokee County Clerk of Superior Court's office. A copy of the recorded easement agreement shall be provided to the Authority before the Construction Plans are approved and stamped.
- 3.) All easements shall allow adequate room to construct the water main and appurtenances. Permanent easements shall be a minimum of 20 feet wide. Wider easements shall be required where water lines are deeper than normal. The maximum cross-slope of the permanent easement shall be 10%.

**Return to:**  
Cherokee County Water & Sewerage Authority  
1957 Authority Drive  
Woodstock, Georgia 30189  
Attn: Jeffery Hooper  
**State of Georgia**  
**County of Cherokee**

**Grant of Easement**  
**Water Line/Main**

This grant of easement made this \_\_\_\_\_ day of \_\_\_\_\_, 20\_\_\_\_\_, from \_\_\_\_\_ of the State of Georgia, and County aforesaid, hereinafter called Grantor, to **CHEROKEE COUTY WATER AND SEWERAGE AUTHORITY**, a Political Subdivision of the State of Georgia, herein called the Grantee.

**WITNESSETH**, the Grantor for and in consideration of the sum of \$1.00 and other valuable considerations in hand paid, at and before the sealing and delivery of these presents, does grant bargain, sell, and convey unto Grantee an easement and perpetual right-of-way over, upon, through, under and/or across the property of the Grantor in Land Lot \_\_\_\_\_, of \_\_\_\_\_ District, 2<sup>nd</sup> Section, Cherokee County, Georgia, and being a strip of land more particularly described and shown on the plat attached hereto as Exhibit "A" and entitled \_\_\_\_\_ (Subdivision Name, Phase, Unit, and or Pod, \_\_\_\_\_ Lot Number \_\_\_\_\_) made a part hereof showing the dimensions and location of this easement. The permanent easement covered by this instrument is \_\_\_\_\_feet wide, with the permission to use an additional \_\_\_\_\_feet wide during construction. The easement begins and ends where the said pipeline enters and leaves the property line as indicated above, and totals approximately \_\_\_\_\_ feet in length.

The easement covered by this instrument is for the purpose of a water line/main and utility installation together with the right to go upon said land to install said water line and installations with the continuous right from time to time to go in and upon said right of way and to construct, install, operate, maintain, inspect, reconstruct, repair, renew, and replace therein the pipeline and other installations as may be necessary; also the right to clear, keep clear, remove and dispose of all undergrowth, trees and other obstructions, objects and structures on said right of way, which are inconsistent with the rights of the Grantee and which may interfere with or endanger the construction, operation and maintenance of said water line/main and other installations; also the right of ingress and egress to and from said right of way over roads, if any, existing at the time for such ingress and egress, for the purpose of constructing, operating, maintaining, repairing, renewing, replacing said water line/main and installations. Said right of way easement may be used by the owners of said land, or their assigns, provided such use is not inconsistent with the rights sought to be condemned and further that such use does not interfere with, injure or endanger said water line/main and other installations and the construction, repairing, renewal and replacement thereof and the uses for the purposes hereinbefore stated.

The Grantor does hereby covenant that they are lawfully seized and possessed of the real estate above described, that Grantor does have good and lawful right to convey the said property, and said property is free from all encumbrances, and that they will forever warrant and defend title thereto against the lawful claims of all persons whomsoever.

IN WITNESS WHEREOF, said GRANTOR hereunder set his hand and affixed his seal on the date written above.

**WITNESS**

**GRANTOR(S)**

\_\_\_\_\_  
Witness (printed name)

\_\_\_\_\_  
Grantor (printed name)

\_\_\_\_\_  
Witness (Signature)

\_\_\_\_\_  
Grantor (Signature)

\_\_\_\_\_  
Grantor (Printed Name)

\_\_\_\_\_  
Grantor (Signature)

**CCWSA ACCEPTANCE**

Sworn to and subscribed before me  
this the \_\_\_ day of \_\_\_\_\_ 20 \_\_\_\_.

\_\_\_\_\_  
CCWSA Representative (Printed Name)

\_\_\_\_\_  
Notary Public (SEAL)

\_\_\_\_\_  
CCWSA Representative (Signature)

# SECTION 300 – WATER MAIN DESIGN CRITERIA

## 301. GENERAL

The criteria listed herein is not intended to cover all aspects of design, but rather to mention the basic guidelines and those particulars that are required by the Cherokee County Water and Sewerage Authority.

## 302. WATER SUPPLY (ALL WATER SUPPLY SYSTEMS)

Residential water supply for domestic use shall be in accordance with the following table and provide a minimum pressure of twenty (20) psi:

### INSTANTANEOUS WATER DEMANDS FOR RESIDENTIAL AREAS

<u>TOTAL NUMBER OF RESIDENCES OR UNITS SERVED</u>	<u>GPM PER RESIDENCE</u>	<u>TOTAL NUMBER OF RESIDENCES OR UNITS SERVED</u>	<u>GPM PER RESIDENT</u>
5	8.0	90	2.1
10	5.0	100	2.0
20	4.3	150	1.6
30	3.8	200	1.3
40	3.4	300	1.2
50	3.0	400	0.9
60	2.7	500	0.8
70	2.5	750	0.7
80	2.2	1,000	0.6

Exceptions may be made when deemed necessary by the Authority. Demand for other than residential to be determined for each specific development.

Residential developments that exceed 150 lots shall have an additional water connection to the existing C.C.W.S.A. water system at each additional entrance.

## 303. WATER MAIN EXTENSION REQUIREMENTS

- 1.) All specifications required by the Authority and by the Georgia Department of Natural Resources must be met by the Developer.
- 2.) Developers are required to extend all mains along their entire property frontage if the existing main is adjacent to the proposed development. The size of the main will be set in accordance with Section 304.

- 3.) If an existing main must be extended to serve a particular development, the Developer will be required to pay all of the initial costs, including but not limited to contract prices, testing fees, engineering fees, etc.
- 4.) In certain circumstances, the Authority may require a larger pipe size to be installed than is required by these standards, and the cost of this over sizing may be funded by the Authority. The developer may be required to pay all of the initial costs. If the purpose of the over sizing is to improve service to existing customers or part of the Authority's master plan for a network of large mains to transfer water around the County, the Authority may enter into negotiations with the Developer to provide funding for the betterment.

#### **304. MINIMUM WATER MAIN SIZES**

- 1.) **Any system, whether served from an existing Authority water main or otherwise, shall have a minimum size of 8 inch pipe installed. Actual sizes may be larger depending on the size required to meet the demand of the proposed development and/or the Authority's master water plan.**
- 2.) Where a water main extension from an existing Authority water main is required along an existing public right-of-way or future supply route, the size of pipe to be used will be either 8", or a size equal to the existing Authority main (if 8" or larger), or the size required to meet the demand of the development, whichever pipe size is largest. In accordance with the C.C.W.S.A.'s Master Water Supply Plan, the Authority may require a larger pipe size to be installed than is required by this standard. The cost of this over sizing may be funded by the Authority, in accordance with the Line Extension Policy (Section 303).

#### **305. WATER MAIN SIZES**

- 1.) **Multi-Family:** Water mains to be no less than 8" in diameter.
- 2.) **Large Shopping Centers, Malls, etc.:** Water mains to be no less than 8" in diameter.
- 3.) **Commercial Areas With Less Than 200,000 Sq. Ft.:** Water mains to be no less than 8" in diameter.
- 4.) **Motels, Light Industry and Schools:** Water mains to be no less than 8" in diameter.
- 5.) **Commercial areas with 200,000 sq.ft. or more, Heavy Industry, Large/Tall Buildings:** Water mains to be no less than 10" in diameter.
- 6.) **Single Family:** Single family residential developments shall use a minimum of 8 inch water mains; larger size mains dependent on demand.



### **306. FIRE PROTECTION**

- 1.) Minimum flows in GPM with 20 psi residual pressure by type of development are recommended as follows:
  - a.) Multi-family: 750 GPM for 30 minutes
  - b.) Shopping Centers: 750 GPM for 30 minutes
  - c.) Motels, Light Industry and Schools: 750 GPM for 30 minutes
  - d.) Heavy Industry, Large/Tall Buildings (Warehouses, Office Buildings, Institutional): 1000 GPM for 45 minutes
  - e.) Residential: 500 GPM for 30 minutes

The Authority may require these recommended flow / duration quantities prior to development of property.

- 2.) Fire hydrants will be required as set forth in these specifications where a proposed system is to be served from an existing Authority water main or in any case where the Authority is to accept a new system for ownership and operation.
- 3.) Fire Protection - Hose Lay  
Hose lay distance is defined as being measured along the route a piece of fire apparatus must travel in laying a fire hose from the fire to the fire hydrant.
- 4.) All plans for development must meet all applicable fire protection codes.
- 5.) All requirements for design criteria and material and construction specifications must be met to secure a permit from the Department of Natural Resources for construction.
- 6.) Spacing of fire hydrants shall be as follows:

**Multi-family:**

- a.) Fire hydrants shall be spaced not more than 500 feet apart with additional fire hydrants located as necessary to permit all portions of buildings to be reached by hose lays of not more than 300 feet in length.

**Shopping Centers, Malls, etc:**

- b.) Fire hydrants shall be spaced not more than 300 feet apart so all portions of buildings can be reached by hose lays of not more than 300 feet in length.

**Motels, Light Industry and Schools:**

- c.) Fire hydrants shall be spaced not more than 500 feet apart so all portions of buildings can be reached by hose lays of not more than 300 feet in length.

**Heavy Industry, Large/Tall Buildings:**

- d.) Fire hydrants shall be spaced not more than 300 feet apart so any portion of the building can be reached by hose lays of not more than 300 feet in length.

**Single Family:**

- e.) Single family residential developments shall have a maximum spacing of 1,000 feet between fire hydrants (500 feet hose lay). Fire hydrants shall typically be located at all intersections and at the end of the line on all cul-de-sacs.

**Water Line Extensions Along Existing Roads/Highways:**

- f.) Fire hydrants spaced not more than 1000 feet apart
- g.) No installation requiring fire hydrants shall have spacing greater than 1000 feet apart as measured along the main supply line.
- h.) Fire hydrants shall be required at the end of all dead-end lines such as those installed in cul-de-sacs.
- i.) Fire hydrants shall be located on the back side of the right-of-way.
- j.) Fire hydrants shall typically be located at all intersections.
- k.) Fire hydrants shall be located at or within 200 feet of the main entrance to the development.

7.) Fire lines shall be metered per Section 310.

8.) Any vault that has a fire department connection must have a fire hydrant on the CCWSA water main side of the vault.

**307. SPRINKLER SYSTEMS**

All in-house sprinkler systems shall have a double check detector assembly equipped with a by-pass meter assembly to monitor low flow. All in ground sprinkler systems shall have a double check backflow preventer. See Section 400.14

**308. DISCONNECTION OF WELLS**

All wells in developments which supply water to distribution are to be disconnected. It shall be the Developer's responsibility to fill, plug, and seal the wells in such a manner which meets the requirements of the Georgia E.P.D. rules for safe drinking water.

**309. LOCATION OF WATER LINES AND FIXTURES**

**1.) Existing County Roads**

On existing roads, water mains shall be located on the South and West side of the road, within five feet of the edge of the right-of-way whenever possible. Water mains shall be installed so that the top of the pipe is a minimum of four feet below final grade, four feet below the edge of the pavement, or four feet below the ditch paralleling the road, whichever is deepest. Permission must be granted by the Authority to vary from this requirement. Fire hydrants on existing roads shall be located as near to the right-of-way as practical or as required by the Cherokee County D.O.T. Fire hydrants shall be located between the water line and the right-of-way. All water mains located within county right-of-way shall be polywrapped.

## 2.) Existing State or Federal Highways and Roads

On existing state or federal highways and roads, water mains shall be located on the South and West side of the road whenever possible, and within five feet of the edge of the right-of-way. Water mains shall be installed so that the top of the pipe is a minimum of four feet below final grade, four feet below the edge of the pavement, or four feet below the ditch paralleling the road, whichever is deepest. Permission must be granted by the Georgia D.O.T. and the Authority to vary from this requirement. Fire hydrants on existing state or federal roads shall be located as near to the right-of-way as practical or as required by the Georgia Department of Transportation. Fire hydrants shall be located between the water line and the right-of-way. All water mains located within State or Federal Highways and Roads right-of-way shall be polywrapped.

## 3.) New Streets in Subdivisions

Water mains on new streets in subdivisions shall be located on the South and West sides of the streets, five feet from the back of the curb. Water mains shall be installed so that the top of the pipe is a minimum of four feet below final grade, four feet below the edge of the pavement, or four feet below the ditch paralleling the road, whichever is deepest. Permission must be granted by the Authority to vary from this requirement. Fire hydrants on new streets shall be located between the water main and the right-of-way and as near to the right-of-way as practical. **The construction of the water main shall not begin until the rough grading is completed and all curbing is installed.**

## 4.) Service Laterals

Service laterals shall be located with a minimum bury equal to that of the main line within the right-of-way and shallowing to a bury of 12 inches at the water meter location. Service line size shall be 1" for single residential service and 1" for double residential service. All long side services for single-family residential shall be encased in 2" PVC pipe. All long side services for developments other than single-family residential shall be encased in 4" P.V.C. pipe. All P.V.C casings for long side services shall be a minimum of 2" in diameter. The contractor shall install the appropriate size service saddle and corporation stop at the main, service laterals and curb stops in meter boxes. For double residential services, the contractor shall provide a cut-off valve on the service on the water main side of the service tee, the service tee, all necessary bends and the curb stops in the meter boxes. The cut-off valve on the service shall be buried without a valve box.

If a 3" meter is used for the development, the Developer must install 4" D.I.P. from the main to the meter, and then utilize a 4" x 3" reducer at the meter. The Authority will not accept 3" service material.

Any portion of service lateral located under pavement shall be encased in P.V.C. pipe, extending a minimum of 3' beyond the edge of pavement and/or sidewalk on both sides of the road. Copper tubing shall be used for all services. A "W" shall be sawed into the curb where each service tap is made for permanent location.

At all common areas within residential or other developments, the Developer shall include in the water plans a water service and meter at the edge of the street right-of-way.

#### **5.) Within Commercial Developments**

Water mains within commercial, multi-family, industrial, office/institutional or school developments shall be installed so that the top of the pipe is a minimum of four feet below final grade, four feet below the edge of the pavement, or four feet below the ditch paralleling the road, whichever is deepest. Permission must be granted by the Authority to vary from this requirement.

#### **6.) Water Valves**

Valves less than 16" shall be gate valves. Valves 16" and larger in diameter shall be butterfly valves. Water valves at intersections shall be located behind the curb or edge of pavement. As a general rule, at intersections, the number of valves shall equal the number of streets leaving the intersection. (In other words, 4 valves where two roads cross and 3 valves where one road tees into another road.) The Authority may require valves in excess of this requirement if the water system layout warrants additional valves.

The maximum spacing of line valves shall be 1,000 feet. The Authority may require closer spacing in high-density urban areas and subdivisions. Generally, the Authority will require a main line valve at every fire hydrant as a minimum. The required spacing shall be at the discretion of the Authority based on individual development circumstances. Unless at an intersection, line valves shall be located at fire hydrants. Concrete valve markers are required at all line valves and at the end of every dead-end line.

All fire hydrants shall be provided with a 6" gate valve between the water main and the hydrant. Wherever possible, the gate valve for a hydrant shall be connected to the main by using a locked hydrant tee. Wherever possible, the Developer shall connect the gate valve to the hydrant by using a locked hydrant adapter or anchor coupling. When connections using locked hydrant fittings are not feasible, the connections shall be rodded together.

All valves shall be provided with valve boxes. Each valve box shall have a concrete collar. These collars must be a minimum of 3 1/2" thick. They shall be square and sized 24" x 24". Pre-cast collars may be used, provided that they are grouted in place to the valve box. The box is to be flush with or a maximum of 1" above the finished grade. The edge of the valve box is to be 1/2" above the edge of the concrete collar.

**7.) Gate Valves and Line Plug**

A gate valve and a minimum of 36 linear feet of pipe shall be provided at the end of all lines for phased developments, and at locations where the water main may be extended in the future for water system improvements. The end of the line shall be provided with a M.J. plug and a thrust collar. A valve marker will be placed directly above the plug.

**8.) Air Release Valves**

Air release valves shall be located where appropriate as determined by the design professional responsible for the water system design. All A.R.V. locations are subject to the approval of the Authority. In general, within subdivisions, A.R.V.'s are not necessary as long as services are located at the water main high points. Valve markers are required at each A. & V. assembly.

**9.) Road Crossings**

At all road crossings, the water main shall be encased in steel casing. The water main inside the casing shall be restrained with "Field Lok" or "Fast-Grip" gaskets. The ends of the casing shall be sealed with brick to secure the position of the main. Steel casings shall be sized as follows:

<u>Water Main Diameter</u>	<u>Steel Casing Diameter</u>
6"	12"
8"	12"
10"	16"
12"	18"
16"	24"
20"	30"
24"	36"

**10.) Ductile Iron Pipe**

Ductile iron pipe shall be required for all water mains, except where the General Manager approves otherwise.

### **11.) Polyethylene Encasement**

Ductile iron water mains shall be provided with black polyethylene encasement whenever the water main either crosses or is in close proximity to a steel gas main. Ductile iron water mains shall be provided with black polyethylene encasement whenever the water main is installed along a county, state or federal road ways. Ductile iron pipe installed in low-lying damp areas and in areas where anode beds are known to exist shall also be provided with polyethylene encasement. The length of the encasement shall be in accordance with D.I.P.R.A. recommendations. The reviewing engineer and the Authority shall have final authority over the required length of the encasement during the plan review process.

### **12.) Easements**

Water mains that are located off the right-of-way shall have a minimum 20 feet wide permanent easement. The maximum cross-slope of the permanent easement shall be 10%. See Section 209 regarding the requirements for water line easements.

### **13.) Acceleration / Deceleration Lanes**

Where applicable, if an acceleration lane or a deceleration lane is to be constructed and will cover or encroach over existing non-DIP water mains, it is the Developer's responsibility to relocate the existing main out from under the proposed pavement and replace the existing main with ductile iron pipe. (See Detail W720)

### **14.) Dams**

Gravity sewer lines may be placed at the toe of the slope of the dam, but not in the slope. Pressurized force mains and water mains shall not be closer than 20 feet to the toe of a dam.

## **310. FIRE LINE METERING REQUIREMENTS**

- 1.) All double check detector assembly, compact fire line assembly, or factory mutual fire line meters as required shall be purchased from the CCWSA. Installation will be the responsibility of the Developer under the supervision of the Authority's inspector.
- 2.) All existing un-metered fire service systems having private fire hydrants, hand hose connections, or sprinkler heads on private property are required to have an underwriter approved double check detector assembly, compact fire line assembly, or factory mutual fire line assembly with the proper backflow device installed as part of the fire service system.

- 3.) Persons making applications for new fire service connections with private fire hydrants, hand hose connections, or sprinkler heads will be required to have an underwriter approved double check detector assembly, compact fire line assembly, or factory mutual fire line assembly with the proper backflow device installed as part of the fire service system.
- 4.) The Contractor shall install a curb stop that can be locked in the ON or Off position on all 2" and smaller DCDA connections.
- 5.) When unauthorized (i.e., non-fire fighting water and/or water use without prior notification and approval of the Authority) is used through the detector meter, the customer will be notified and given sixty(60) days to repair the leak or flow problem. If the meter continues to show usage after the next sixty(60) day reading cycle the customer will then be charged an illegal hook-up fee determined by the Authority. The Authority will then determine if a compact fire line assembly or factory mutual fire line meter will need to be installed. If the repair is not made within the given time, this will result in notification to the fire district office and possible disconnection of fire protection water service until corrective action is taken and approved by the Authority.
- 6.) If the normal usage of the development is such that the service meter required to serve the development is larger than 2", the Authority shall require that the Developer install an 8" or larger compact fire line meter assembly and vault to serve both the normal usage and the fire line needs of the development. If the normal usage of the development is such that a 2" meter or smaller can be used to serve the development, the Developer will be allowed to use a 2" or smaller meter for the normal usage and a detector meter assembly on the fire line.
- 7.) When unauthorized water is used through a detector meter in three or more billing periods in one calendar year, it shall be replaced with a factory mutual fire line meter. Unauthorized use of water is defined as non-fire fighting water and/or water use without prior notification and approval of the Authority.

The regular monthly fire service standby charge shall be continued for fire service installations having a detector or factory mutual fire line meter. The water that is measured by the detector meter will be billed at five times the normal water charge. If the services of legal council are required to collect bills, the cost of council shall be added to the billing.

- 8.) The detector meters on the backflow preventers shall be Sensus ¾" meters equipped with a Touch Read Pit Lid Register compatible with the Authority's meter reading equipment.
- 9.) All domestic water supplies must be metered with a proper meter.

- 10.) Installation of detector meters or factory mutual fire line meters as required will be the responsibility of the Developer under supervision of the Authority's inspectors.
- 11.) The Authority shall have the right to cut off water service to buildings whose owners refuse to comply with these provisions upon proper notification of sixty (60) days.

### **311. WATER PUMP STATIONS**

Where pump stations are required to serve a development, the Developer's design professional shall prepare and submit detailed plans, specifications and calculations for the Authority's review. Design requirements shall be discussed in the preliminary stages of plan review. Each case shall be reviewed individually, and the Authority shall retain the right to require changes to the pump station design or materials at the Authority's discretion.

### **312. WATER MAINS ON PRIVATE ROADS**

The Authority will accept for ownership water mains installed along roadways that are not dedicated for public use (i.e., are without public right-of-way) if the property owners will dedicate a permanent easement to the Authority.

### **313. PROTECTION OF WATER SUPPLY AND OTHER UTILITIES**

- 1.) The Cherokee County Water and Sewerage Authority has an established Cross-Connection Program to prevent the entry of contaminants or pollutants into any area of the potable water supply through the control of cross connections. It is illegal to introduce any substance into or to have any cross connections with the potable water supply. There shall be no physical connection between a public or private potable water supply system and a sanitary sewer which would permit the passage of any sewage or polluted water into the potable water supply.

#### **2.) Separation between Water Main and Sanitary Sewer Mains**

Whenever possible, water mains should be laid at least 10 feet horizontally from any existing or proposed sanitary sewer main. Should conditions prevent a separation of 10 feet, the lines shall be laid in separate trenches. In either case, the elevation of the invert of the water main shall be at least 12 inches above the crown of the sewer. These distances are measured edge to edge.



When water mains cross over sewer mains, the water main shall be laid so that the invert of the water main shall be at least 18" above the crown of the sewer. The two pipes shall be installed such that a full length of pipe will be centered over the crossing so that all joints will be separated as much as possible. Ductile iron pipe shall be installed for both mains.

In the rare circumstance when the 18" clearance between the water and sewer mains cannot be maintained, the D.I.P. mains shall be installed as described in the paragraph above with the joints as far apart as possible, plus both mains shall be placed in casing for a distance of 10 feet on each side and grout each end of casing.

# **SECTION 400 - MATERIALS FOR WATER LINE CONSTRUCTION**

## **401. GENERAL**

All materials used in the work including equipment shall be new and unused materials of a reputable U.S. Manufacturer conforming to the applicable requirements of these Specifications, and no materials shall be used in the work until they have been approved by the Authority. Any reference to a AWWA, ANSI or other such specification shall mean the latest revision published.

## **402. WATER MAIN**

### **1.) Ductile Iron Pipe**

Ductile iron pipe shall be thickness Class 50, designed in accordance with AWWA C150 - latest revision and manufactured in accordance with AWWA C151 - latest revision. Ductile iron pipe shall have an outside bitumastic coating per AWWA C151 - latest revision. It shall have an inside standard cement lining with bituminous seal coat per A.W.W.A. C104 - latest revision.

Pipe Joints - except where restrained, flange, or mechanical joints are specified, straight pipe joints shall be push on, rubber gasket type such as Fastite or alternate acceptable to the Authority conforming to A.W.W.A. C111-latest revision. Pipe shall be in 18' to 20' nominal lengths with standard deflection pipe sockets. Where restrained joints are shown, the joints shall be "Flex-Ring" type as made by American Ductile Iron Pipe, TR Flex as made by U.S. Pipe or alternate acceptable to the Authority.

Where river crossing pipe is required, the pipe shall be "Flex-Lok Boltless Ball Joint Pipe" as manufactured by American Pipe or alternate acceptable to the Authority. Where specified, flanged pipe shall meet AWWA C151 specifications and be used with fittings meeting AWWA C110 or AWWA C153.

Certificates of conformance with the foregoing specifications shall be furnished with each lot of pipe supplied.

## **2.) Copper Tubing for Water Service Laterals**

Service lateral pipe shall be copper service pipe, type K, soft temper, seamless copper tubing, conforming to ASTM B-88, latest revision. Compression joints will be used.

Service line size shall be 1" for single residential service and 1" for double residential service. Service line size shall be 1" minimum for all other types of developments. All service lines smaller than four inches in diameter shall be copper. Service lines four inches in diameter and larger shall be ductile iron.

## **3.) P.V.C. Casing for Services**

Long side service lines shall be bored and encased in P.V.C. pipe. PVC casing pipe used for long-side services shall be schedule 40 and a minimum of 2" in diameter for residential developments and 4" in diameter for all other type developments.

## **4.) Casing Pipe**

Casing pipe, where required under the street, shall be smooth steel pipe conforming to A.S.T.M. Designation A-139, Grade B, electric fusion welded steel pipe. The pipe shall have a minimum yield strength of 35,000 psi. The exterior and interior of the pipe shall have a bismastic varnish coating. Minimum wall thickness: 0.250" or as required by the D.O.T. or other governing body having jurisdiction over the crossing.

## **5.) Ductile Iron Pipe Fittings**

Fittings shall be ductile iron and furnished in accordance with AWWA C110 or AWWA C153, latest revisions, and shall be a minimum of 350 psi pressure class rating. Joints shall be mechanical joint with retainer glands conforming to AWWA C111, latest revision, except where approved otherwise by the Authority. Cement mortar lining conforming to AWWA C104 or fusion-bonded epoxy coating conforming to AWWA C116 shall be furnished for fittings.

### **403. FIRE HYDRANTS**

All fire hydrants shall comply in all respects with Authority Standards and shall be designed and manufactured to comply with the latest revision of AWWA C502. The hydrants shall be designed for 250 pounds working pressure. The hydrants shall be of simple design, easy to operate, effectively and positively drained and protected from damage by freezing, and convenient for repairing and replacing parts.

Hydrants shall be equipped with one 4-1/2" diameter pumper nozzle and two 2-1/2" diameter hose connections, which shall have threads meeting the latest requirements of the State Fire Insurance Commission. Hydrants shall have a safety flange on the barrel and a safety coupling on the valve stem to prevent damage to barrel and stem in case of traffic accident. Safety coupling shall be set 2" to 6" above the finish grade. Hydrants shall be Mueller Company's Super Centurian traffic model, M&H Style 129 traffic model, or U.S. Pipe Metropolitan 250, Model 94.

The connection at the base of the hydrant shall be mechanical joint with ductile iron retainer gland for 6" ductile iron pipe. The valve opening shall meet the requirements of the AWWA Specifications for a 5-1/4" hydrant. The valve, valve seat and inner working parts shall be easily accessible. The height from the surface of the ground to the bottom of the hose nozzle shall be no less than 24". Each hydrant shall be neatly painted with a red reflecting paint.

Each hydrant shall be tested to 200 psi. The first test shall be made with the valve closed. The second test shall be made with the main valve open but all nozzles closed. While the test is being carried on, the hydrant shall be subjected to a hammer test. Any hydrant showing defects by leakage, sweating, or otherwise shall be rejected. The barrel and all parts shall withstand these tests. These tests shall be made in the field after the hydrants are installed.

Leads from the main line to the fire hydrant shall use 6" ductile iron pipe and shall have a 6" gate valve between the main line and fire hydrant. The valve shall be connected to the main line by using a locked hydrant tee, equal to American Pipe model A-10180 or alternate acceptable to the Authority. Retainer glands or steel rods must be used to insure adequate connection of fire hydrant to valve. When the hydrant is close enough to the valve to allow its use, the hydrant shall be connected to the valve by using an anchor coupling acceptable to the Authority.

## **404. VALVES AND ACCESSORIES**

### **1.) Gate Valves**

Valves 16" and smaller shall be gate valves. The valves shall be of non-rising stem design, and have an iron body, bronze mounted, resilient seated, meeting all requirements of AWWA C509 or AWWA C515. All interior ferrous surfaces of valves shall have a fusion-bonded epoxy coating meeting the requirements of AWWA C550. Valves shall be designed for a minimum working pressure of 250 psi and shall have 2" square operating nuts, except in meter vaults where handwheels shall be installed. Valves for pipe smaller than 4" in diameter shall have handwheels suitable for use inside standard valve boxes. Valves shall open when turned counter-clockwise.

Valves sized 2" through 12" shall be Mueller Co. A-2360 with mechanical joints or alternate acceptable to the Authority. 16" valves shall be Mueller Co. A-2361 with mechanical joints or alternate acceptable to the Authority. Mechanical joints shall be fitted with retainer glands. Where flange joints are used, flanges must meet the requirements of AWWA C115, latest revision.

### **2.) Butterfly Valves**

Valves 16" and smaller shall be gate valves. Valves larger than 16" in diameter shall be butterfly valves. All butterfly valves shall be bubble-tight closing at the rated pressure with flow in either direction, and shall be satisfactory for applications involving throttling service and frequent operations or operations after long periods of inactivity. Valves shall meet the full requirements of AWWA C504, latest revision, for 250 psi working pressure and shall be suitable for above ground or buried service.

All interior ferrous surfaces of valves shall have a fusion-bonded epoxy coating meeting the requirements of AWWA C550. Valve bodies shall be equipped with integrally cast mechanical joint ends meeting AWWA C111, latest revision. Mechanical joints shall be furnished with retainer glands.

Butterfly valves installed underground shall come equipped with a manual operator. This manual operator shall be of the traveling nut, self-locking type and shall be designed to hold the valve in any intermediate position between fully open and fully closed without creeping or fluttering. Operators shall be equipped with mechanical stop-limiting devices to prevent over travel of the disc in the open and closed positions.

Valves shall open when turned counter-clockwise. Operators shall be fully enclosed and designed for buried operation.

### **3.) Valve Boxes**

Valves boxes for valves shall be approved standard cast iron adjustable shaft boxes having a minimum shaft diameter of 5-1/4". The casing shall be coated with two coats of bitumastic paint.. The lids of all boxes shall bear the word "Water" or the letter "W". Boxes shall be Vulcan Pattern VVB-4 or alternate acceptable to the Authority.

### **4.) Air and Vacuum Relief Valve Assemblies**

The valve shall be a combination air/vacuum- double orifice automatic air release valve with 2" connection to the pipe line. The valve shall be of one-piece body design. The internal parts shall have a small orifice within tripod for small air discharge and a big orifice within bonnet of base housing for main air discharge and allow air to enter in the event of a vacuum condition. The material of the body and the flow shall be Delrin (Poloximethylene,POM). The valve sealing is rubber made of EPDM. The valve shall have a protection cap of PE. Air and vacuum valves shall be manufactured by H-TEC or alternate acceptable to the Authority. Valves shall be a minimum of 1 inch.

Gate valves between water main and air release valve shall be bronze, solid wedge with screw connection equal to Jenkins Company Figure 370 or alternate acceptable to the Authority. Meter box shall be equal to the DFW Style D-1200 or alternate acceptable to the Authority.

### **5.) Tapping Sleeves**

Tapping sleeves for existing water mains sized 4" through 12" in diameter for 8" and smaller taps can be either an American Flow Control Series 2800 or a Ford Stainless Style FAST Tapping Sleeve or alternate acceptable to the Authority. The stainless steel FAST style shall only be used in cases where the normal working pressure is less than 125 PSI and the tap is 8" in diameter or smaller. Where the normal working pressure exceeds 125 PSI or the tap is larger than 8" in diameter, the sleeve shall be an American Flow Control Series 2800 or alternate acceptable to the Authority. Both types of sleeves shall have a flanged connection to the tapping valve.

Tapping sleeves for existing water mains sized larger than 12" in diameter shall be an American Flow Control Series 1004 or alternate acceptable to the Authority. The sleeve shall be mechanical joint type with a flanged connection to the tapping valve. It shall be capable of withstanding a working pressure of 250 psi for the pipe size and type shown.

### **6.) Tapping Valves**

Tapping valves shall be American Flow Control Series 2500, mechanical joint by flanged ends, 250 psi, or alternate acceptable to the Authority.

## **7.) Pipe Connection Couplings**

Pipe connections between new pipe and existing pipe shall be made with Dresser Style 90 long steel couplings for pipe sizes 2" and below; for pipe sizes above 2", M.J. solid sleeves (long style) shall be used. Spacer rings must be used at all solid sleeve locations. A spacer ring is defined as a short section of pipe cut to fit into the gap between the two plain ends of pipe at the sleeve location. Field joints shall be made to insure permanently tight joints under all reasonable conditions of expansion, contraction, shifting, etc.

## **8.) Curb Stops**

All metal parts of curb stops shall be made of bronze. The stops shall be Ford B43-332W with padlock wings or alternate acceptable to the Authority for copper service pipe. The cock shall be operated with a combined cap and tee and shall open when turned counter-clock wise. The stop shall be compression joint inlet with meter swivel nut outlet.

## **9.) Service Line Couplings**

Service line pipe couplings shall be compression style Ford C44 or alternate acceptable to the Authority. Branch connection shall be 1" x 3/4" x 3/4" Ford Y44-243 or alternate acceptable to the Authority. A cut-off valve (such as a Ford B44-444 Curb Stop) shall be installed on the water main side (the 1" side) of the wye and shall be buried without a valve box.

Female compression adapters shall be a Mueller-H-15451 or alternate acceptable to the Authority.

Male compression adapters shall be a Mueller-H-15428 or alternate acceptable to the Authority.

## **10.) Corporation Cocks**

Corporation stops shall have AWWA tapered threaded inlet and compression joint outlet connection for copper service pipe. All metal parts of the stop assembly shall be made of bronze. The stop shall be operated with a tee head and shall open when turned counter-clockwise. Corporation stops for copper service line pipe outlets shall be Ford FB1000 or alternate acceptable to the Authority.

## **11.) Electric Conductive Wire**

Where PVC pipe is allowed to be installed, electric conductive wire shall be placed in the trench one foot above the pipe. The tracer wire shall be 12 gauge, plastic coated copper wire suitable for this purpose. Foil tape will not be acceptable.

## 12.) Meter Boxes for Single Family Residential (Subdivisions)

Meter boxes shall be the "Rome" type of meter box as manufactured by Russell Foundry and Mfg. Co. in Alabama and shall be of cast iron, oval shape and have minimum inside dimensions of 19 inches by 10 inches and shall be at least 11 ½ inches deep. Lids shall fit snugly. Lids shall be banded together with a steel strapping and painted with black asphaltic paint before shipping. The combined weight of the box and lid shall be not less than 60 lbs.

The lid shall be of cast iron and shall be designed to rest firmly on the seat inside the box and over-hang to prevent dirt from falling into the seat. The lid shall be easily removed and replaced.

## 13.) Service Saddles – Double Strapped

Double strapped service saddles are required for services 2-1/2" and smaller in diameter and shall be Ford F202 double strap clamps suitable for use with ductile iron or PVC pipe or alternate acceptable to the Authority. (See Section 404.5 regarding the requirements for 4" and larger diameter taps.)

If a 3" meter is used for the development, the Developer must install 4" DIP from the main to the meter, and then utilize a 4" x 3" reducer at the meter. The Authority will not accept 3" service material.

## 14.) Meters and Backflow Preventers

**All meters shall be purchased from CCWSA.** All meters 2" and smaller will be installed by the authority in boxes located at the edge of the right-of-way. All meters 3" and larger will be installed by the Developer under the supervision of the Authority's inspector. All meters 3" and larger shall be in vaults located at the edge of the street right-of-way or proper easement shall be provided. No meter will be set until the meter set fee is paid and a building permit issued for the lot requesting service. Services shall be sized and located as shown in the **Detail-W724**. All meters must register in gallons and programmed to read in thousand gallon units.

All meters must be installed with at least 5 times the pipe diameter of straight pipe the same size as meter on the inlet and outlet side to permit proper calibration.

All 3" and larger meters shall be a Sensus Omni Meter or Sensus compact fire line assembly equipped with an ICE register programmed to read in thousand gallon units. Each register shall be equipped with a Touch Read Pit Lid Register compatible with the Authority's meter reading equipment.

All meter installed inside vaults must be level parallel, vertical, and horizontal to the



meter vault.

A 4 foot number 57 stone gravel bed and or a positive drain shall be required underneath all vaults for drainage. All bedding must be level for proper functioning of the meter.

Stand-on –pipe supports are required underneath the meter and wheel valves for support of the weight.

All openings or holes in the vault will be required to be enclosed with concrete and made water tight.

**15.) Polyethylene Tubing For Ductile Iron Pipe**

Where required by the Authority, polyethylene encasement tubing shall be manufactured of virgin polyethylene material conforming to the requirements specified in AWWA C105, Section 4.1.1 for linear, low density polyethylene film. The polyethylene film shall have a minimum thickness of 8 mil. Black polywrap shall be used for water mains and green polywrap shall be used for sewer force mains.

**16.) Valve Markers**

One concrete valve marker shall be furnished and set at each line valve. The marker shall be made of 3,000 PSI concrete, and shall be four feet (4') long and 4" on each side, with two #3 reinforcing bars as shown on the detailed drawings.

The markers shall be set an even number of feet between the center line of the valve and the center line of the aluminum disc in the top of the marker, and the distance in feet between the valve and marker shall be stamped in the marker at the time of setting.

**17.) Valve Box Collars**

Each valve box shall have a concrete collar. These collars must be a minimum of 3 1/2" thick. They shall be square and sized 24" x 24". Precast collars may be used, provided that they are grouted in place to the valve box. The box is to be flush with or a maximum of 1" above the finished grade. The edge of the valve box is to be 1/2" above the edge of the concrete collar.

**18.) Concrete for Thrust Blocks and Thrust Collars**

Concrete for thrust blocks and thrust collars shall have a minimum compressive strength of 3,000 PSI at 28 days.

**19.) Subgrade Stabilizer Stone**

Stabilizer for subgrade shall be either approved crushed stone or gravel, uniformly graded from 1/4" to 3/4" in size.

**20.) Retainer Glands**

Retainer glands for mechanical joints shall be EBAA Mega-Lug or alternate acceptable to the Authority.

**21.) Locked Fire Hydrant Tee And Adapter**

Locked fire hydrant tees shall be American A-10180 or alternate acceptable to the Authority. Locked hydrant adapter (anchor coupling) shall be American A-10895 or alternate acceptable to the Authority.

**22.) "Fast-Grip" Gaskets**

Inside of all casings and wherever else required by the Authority, DIP water main joints shall be slip joint restrained by using American Pipe "Fast-Grip" gaskets, U. S. Pipe "Field-Lok" gaskets or alternate acceptable to the Authority.

**23.) Nitrile (NBR) Gaskets**

In areas where underground fuel storage tanks are located or are known to have been located and as directed by the Authority, the D.I.P. water main joints shall use American Pipe "Nitrile (NBR)" (Acrylonitrile Butadiene) gaskets or alternate acceptable to the Authority.

**405. GENERAL REQUIREMENTS**

Any pipe, solder or flux used in the installation or repair of the water lines shall be lead-free. Pipes and fittings shall not contain more than 8.0% lead and solder and flux shall not contain more than 0.2% lead.

## **SECTION 500 - CONSTRUCTION METHODS**

### **501. EXCAVATION GENERAL**

It is the responsibility of the General Contractor, any subcontractor, their employees, and inspectors of job sites to observe all safety regulations. Deficiencies in safety measures noted should be immediately reported to the Contractor's superintendent, so that immediate corrective measures can be taken by the Contractor. It is, however, the Contractor's responsibility to conform to all safety regulations and practices as pertain to his construction site. The Contractor shall contact the U.S. Department of Labor, Occupational Safety and Health Administration (OSHA), Region IV, Atlanta, Georgia for any assistance needed to complying with the appropriate regulations.

All unsuitable excavated material must be properly disposed of in a manner acceptable to the Authority and in a manner that will not adversely affect the environment.

It shall be expressly understood that these Standards are for the installation of all underground water mains and appurtenances. All work shall conform to the applicable provisions of the AWWA Specifications of latest revision except as otherwise specified herein.

### **502. EROSION AND SEDIMENTATION CONTROL**

All erosion and sedimentation control methods shall be in compliance with the State, Federal and Local regulations, the Manual for Erosion Control in Georgia and the EPD requirements regarding the NPDES Storm Water Monitoring permit.

The Contractor shall designate one individual to be responsible for the implementation and maintenance of erosion and sedimentation controls on a 24-hour, everyday basis. The Contractor shall furnish the Authority the individual's name, address, and 24-hour telephone number. This information shall be updated as is necessary.

### **503. CLEARING AND GRUBBING**

Areas for water system construction shall be cleared and grubbed. All trees, shrubs, stumps, brush, paving and other waste material must be removed from the site.

On water line extensions to the development, the road right-of-way shall be cleared to the width necessary for trenching and pipe laying operations. All stumps and roots within the trench dimensions shall be grubbed to such depths and widths as will enable the trenching to be done. The trees, brush, stumps and other debris from clearing shall be removed from the site. No trees or stumps shall be pushed beyond the right-of-way or buried nor shall any timber beyond the right-of-way be damaged. The Contractor shall remove only such trees on or along the work as the Chief Inspector permits, and shall carefully protect all other trees adjacent to the work. The Contractor shall not permit excavating machinery or trucks to scrape the bark or tear the limbs from the trees, nor connect ropes or guy cables to them.

### **504. TRENCH EXCAVATION**

- 1.) It is the responsibility of those installing water mains and related appurtenances to conform to OSHA regulations, 29 CFR Part 1926, Subpart P, Paragraph 1926.650 through 1926.653 during trench excavation. OSHA publications are available to assist the Contractor in having a safe construction site (i.e. **Excavating and Trenching Operations**, 1995(Revised), OSHA 2226). Publications from OSHA can be obtained by contacting OSHA Publications Distribution, Washington, D.C. The Authority assumes no liability nor responsibility for unsafe trench conditions.
- 2.) Trenches shall have a minimum width of twelve (12) inches plus the diameter of the outside of the bell of the water main and the depth thereof shall be such that the water mains shall be installed so that the top of the pipe is a minimum of four feet below final grade, four feet below the edge of the pavement, or four feet below the ditch paralleling the road, whichever is deepest. Permission must be granted by the Authority to vary from this requirement. Maximum trench width at the top of the pipe shall not be more than the outside diameter of the bell plus two feet. The sides of the trench above the pipe shall be sloped or benched as necessary to maintain stability. Minimum pipe cover shall be as shown on the approved plans.
- 3.) Pipe trenches shall be straight and true to grade and in the location shown on the plans. Trenches shall be dug so that the pipe can be laid to the alignment and depth required, and the trench shall be of such width and shall be braced and drained so that the workmen may work therein safely and efficiently. No chocking under the pipe will be permitted. All joints shall be as specified herein. Excavation must be made under the bell of each pipe so that the entire length of the pipe will lie uniformly on the bottom of the trench and the pipe weight shall not rest on the bells.

- 4.) Trenches shall be free of water during the work. Whenever water is present in the trench, it shall be removed in a manner satisfactory to the Authority and enough backfill shall be placed on the pipe to prevent floating. Any pipe that has floated shall be removed from the trench and relaid later during dry conditions. No pipe shall be laid in wet trench conditions that preclude proper bedding, or on frozen trench bottom, or when, in the opinion of the Authority, the trench conditions or the weather are unsuitable for proper installation.

The Contractor shall do all necessary pumping or bailing, build all drains and do all other work necessary at his own expense to keep the trenches clear of water during the progress of the work. No structure shall be built or pipe shall be laid in water, and water shall not be allowed to flow over or rise upon any concrete, masonry or pipe until the same has been inspected and the concrete or joint material has thoroughly set. All water pumped, bailed or otherwise removed from the trench or other excavation shall be conveyed in a proper manner to a suitable place of discharge where it will not cause injury to the public health or to public or private property or to work completed or in progress, or to the surface of the streets or cause any interference with the use of same by the public.

- 5.) All changes in grade shall be made gradually. At points of interference with storm sewers and cross drains on D.O.T. right-of-way, the pipe will be run under the conflicting utility unless the water main can be installed above the storm sewer while maintaining both the required one foot separation and the required cover specified in section **504.2** above. Where the water main crosses beneath a storm sewer, there shall be a minimum of 12" clearance between the main and the storm sewer.
- 6.) In laying pipe across water courses, the top of the water main or casing shall be a minimum of three feet below the creek or river bed. Three feet of cover shall be maintained over water mains crossing ditches or depressions of any kind. Railroad crossings shall be installed according to American Railway Engineering Association requirements.
- 7.) Where necessary, the line shall be lowered at valves so that the top of the valve stem is approximately three feet below the finished grade. The trench shall be deepened to provide a gradual approach to all low points of the line.

- 8.) No excavation shall be made under highways, streets, alleys or private property until satisfactory arrangements have been made with the State, City, County or owners of the property to be crossed. All excavated material shall be placed so as to not interfere with public travel on the streets and highways along which the lines are laid. All work shall be performed to cause the least possible inconvenience to the public. Adequate temporary bridges or crossings shall be constructed and maintained where required to permit uninterrupted vehicular and pedestrian traffic. Not more than 100 feet of trench shall be opened on any line in advance of pipe laying. The Chief Inspector shall have the right to limit the amount of trench open at any one time to less than 100 feet if he believes the reduced limits are necessary.
- 9.) All excavations shall be adequately guarded with barricades and lights in compliance with all OSHA, Cherokee County and Georgia Department of Transportation requirements so as to protect the public and workers from hazard.
- 10.) When possible, all crossings of paved highways or driveways shall be made by boring or jacking the pipe under the pavement and shall be done in such manner as not to damage the pavement or sub-grade, unless the casing or pipe is in solid rock, in which case the crossing shall be made by the open cut method, wet bore or by tunneling.

Wherever streets, roads, or driveways are cut, they shall be immediately backfilled and compacted after the pipe is laid and shall be maintained in first-class condition as passable at all times until repaved. Backfilling, compaction, dressing and clean-up shall be kept as close to the line laying crew as is practical, and negligence in this feature of the work will not be tolerated.

Streets, sidewalks, parkways, and other public and private property disturbed in the course of the work shall be restored to as near as original condition as possible or better in a manner satisfactory to the Authority.

- 11.) In excavation and backfilling and laying pipe, care must be taken not to remove or injure any water, sewer, gas or other pipes, conduits or other structures without an order from the Designer. When an obstruction is encountered, the Contractor shall notify the Designer who will have the Owners of the obstruction adjust same or make necessary changes in grade and/or alignment to avoid such obstruction. Any house connection, drains or other structures damaged by the Contractor shall be repaired immediately.
- 12.) All excavation shall be placed on one side of the trench, unless permission is given by the Authority to place it on both sides. Excavation materials shall be so placed as not to endanger the work and so that free access may be had at all times to all parts of the trench and to all fire hydrants or water valve boxes, etc.

- 13.) Excavations adjacent to existing or proposed buildings and structures, or in paved streets or alleys shall be adequately protected by the use of trench boxes, sheathing, shoring and bracing to support the sides of the excavation and to prevent cave-ins of the excavation, or the undermining or subsequent settlement of adjacent structures or pavements. Underpinning of adjacent structures shall be done when necessary to maintain structures in safe condition.
- 14.) Construction occurring around active sewer systems shall be done in such a way so as to prevent the passage of wastewater onto the ground. Absolutely no wastewater shall be allowed to spill onto the ground.

**505. ROCK EXCAVATION**

Wherever rock is encountered in the excavation, it shall be removed by suitable means. Drilling and blasting operations shall be conducted with due regard for the safety of persons and property in the vicinity and in strict conformity with requirements of all ordinances, laws and regulations relative to the handling, storing and use of explosives. The Developer is fully responsible for filing for and acquiring any blasting permits which may be required by those agencies with such jurisdiction. Before blasting, the Contractor shall cover the excavation with heavy timbers and mats in such a manner as to prevent damage to persons or the adjacent property. Rock excavation near existing pipelines or other structures shall be conducted with the utmost care to avoid damage. The Contractor shall be wholly responsible for any damage resulting from blasting, and any injury or damage to structures or property shall be promptly repaired by the Contractor to the satisfaction of the Authority and property owner.

Rock in trenches shall be excavated over the horizontal limits of excavation and to depths as follows:

<u>Size of Pipeline, Inches</u>	<u>Depth of Excavation Below Bottom of Pipe, Inches</u>
4 and Less	4
4 to 6	6
8 to 18	8
18 to 30	10
Over 30	12

The space below grade for pipe lines shall then be backfilled with subgrade stabilizer or other approved bedding material and compacted.

In rock excavation, the backfill from the bottom of the trench to one foot above the top of the pipe shall be finely pulverized soil, free from rocks and stones. The rest of the backfill shall not contain over 50% broken stone, and the maximum sized stone placed in the trench shall not exceed two inches (2") in diameter. Excess rock and fragments of rock larger than 2" in diameter shall be loaded and hauled to disposal. If it is necessary, in order to comply with these specifications, selected backfill shall be borrowed and hauled to the trenches in rock excavation. Sides of the trench shall be trimmed of projecting rock that will interfere with backfilling operations. Rock excavation by blasting shall be at least 75 feet in advance of pipe laying.

## **506. SUBGRADE AND BEDDING**

The bottom of the trench shall be accurately cut to grade so that the pipe will have a longitudinal bearing on undisturbed soil for the full length of the pipe, except for such distances that are necessary for bell holes.

If the soil at the bottom of the trench is in such condition that it cannot be properly shaped or graded, due to the hardness of the soil and in all cases where rock or shale is encountered at sub-grade, the trench shall be refilled with suitable backfill material to the required sub-grade elevation, thoroughly tamped with mechanical tampers and shaped to fit the outside of the pipe as specified in the preceding paragraph. Wherever water is encountered in conjunction with the additional sub-grade excavation, the backfill shall consist of sub-grade stabilizer stone.

In the event that a trench is excavated below grade, the Contractor shall refill the trench to the proper grade with suitable, thoroughly compacted material. Allowable soils shall be dry course-grained soils ranging from well-graded gravel-sand mixtures with little or no fines to clayey sands and sand-clay mixtures with appreciable amounts of fines. All soil materials shall have 100% passing a 1-1/2 inch sieve and a maximum of 55% passing a no. 200 sieve. The maximum volume change allowable shall be 15%. Allowable soils shall be Class I and Class II as defined in Section 810, of the Georgia Department of Transportation Specifications for the Construction of Roads and Bridges.

All gravel or crushed stone used for Class "C" bedding shall have a gradation equal to or smaller than #57 stone in order to limit the void area, and all the material must pass a 1-1/2 inch sieve. Where sand or other acceptable soil is used, it shall be spread over the trench bottom, compacted to at least 90% maximum density and shaped before placing the pipe; after the pipe is placed, additional material shall be compacted under the haunches and for the full trench width as described above.



## **507. INSTALLATION OF WATER MAIN**

Pipe and accessories shall at all times be handled with care to avoid damage. Proper and suitable tools and equipment for the safe and convenient handling and laying of pipe shall be used. Whether moved by hand, skidways or hoists, material shall not be dropped or bumped. Great care shall be taken to prevent the pipe from being damaged, particularly the cement lining on the interior of ductile iron pipe. Each joint of pipe shall be unloaded opposite or near the place where it is to be laid in the trench. All pipe shall be carefully examined for cracks and other defects. All such material that is defective in manufacture, has been damaged in transit, after delivery or in installation, shall be removed from the job site and replaced with new material.

All pipe shall be laid straight, true to line and grade. Bell and coupling holes shall be dug in the trench and the pipe shall have a continuous bearing with the trench bottom between bell or coupling holes. No shimming or blocking up of the pipe shall be allowed. When the work is not going on, all pipe openings shall be securely closed by the insertion of the proper size plug and caulking so that dirt and debris will not be washed into the pipe in case of rain. The inside of the pipe shall be clean and free of trash and dirt, and if necessary a swab or brush shall be used to clean the pipe before lowering it into the trench. All pipe and fittings shall be kept clean until completion of the work.

Water mains shall be joined by "push-on" joints using elastomeric gaskets to affect the pressure seal. The spigot end of the pipe and the inside of the bell shall be thoroughly cleaned and the gasket inspected to see that it is properly placed; Lubricant shall be applied to the spigot end of the pipe and it shall be inserted into the bell of the adjoining pipe to the stop mark on the pipe, and the assembly shall be made as recommended by the pipe manufacturer. Lubricant used must be non-toxic and supplied or approved for use by the pipe manufacturer.

Restrained joints shall be provided where specified on the approved plans and shall be of the type specified in the Section 400 of these specifications. Assembly shall be in accordance with the manufacturer's recommendations. While the typical bedding required for water mains is Type 3, all restrained pipe and bends shall have Type 4 bedding.

Water shall not be allowed to run or stand in the trench before the trench has been backfilled. The Contractor at no time shall open up more trench than his available pumping facilities are able to dewater.

Where allowed by the Authority, PVC water mains shall be installed in accordance with the requirements of ASTM D 2774, latest revision. Where PVC pipe is installed, electric conductive wire shall be placed in the trench one foot above the pipe.

Ductile iron water mains shall be wrapped in black polyethylene tubing where required by the Authority. Polyethylene tubing shall be installed in accordance with AWWA C105, Method A, latest revision.

At changes in direction of the main and at other points shown on the plans or directed by the Engineers, the line shall be adequately blocked with concrete or restrained in some other manner approved by the Authority. The Chief Inspector shall be notified by the Contractor before blocking is placed. Prior to blocking any joint or fitting with concrete, that joint or fitting shall be wrapped with polyethylene film in such a manner that the concrete will not stick directly to the pipe but that the load bearing capacity of the blocking will not be affected.

For water mains, the Contractor shall place a vertical piece of 2" diameter PVC pipe on top of the pipe at all bends, fittings, valves, elevation transitions and every 50' along the length of the water main for the purpose of enabling the surveyor to determine the water main elevation for "As-Builts". The Contractor will then be responsible for removing the vertical PVC sections after the as-built locations have been verified by the Authority. The PVC shall be capped by approved method to prevent trash from entering the PVC prior to the depth being measured.

## **508. BACKFILLING TRENCHES**

- 1.) Backfill material shall consist of fine, loose earth containing sufficient but not excessive moisture content for thorough compaction. Material that is too dry for adequate compaction shall receive a prior admix of sufficient water to secure adequate moisture content. Material having excessive water content shall not be placed at any time. Backfill material shall be free of large clods, stones, vegetable matter, debris, and other objectionable material. All unsuitable excavated material and excess material must be properly disposed of in a manner that will not adversely affect the environment.

After the pipe has been laid, backfilling shall be done in two (2) distinct operations. In general, all backfill beneath, around and to a depth of twelve (12") inches above the top of the pipe shall be placed by hand in four (4") inch layers for the full width of the trench and thoroughly compacted by hand with vibratory equipment. The remainder of the backfill shall be placed in 6" layers and compacted to the top of the trench, either by pneumatic hand tamps, hydro-tamps, or other approved methods. Care shall be taken so that the pipe is not laterally displaced during backfilling operations. The backfill lifts shall be placed by an approved method in accordance with that hereinafter specified. Backfill materials shall be the excavated materials without bricks, stone, or corrosive materials.

- 2.) Backfill under permanent concrete or bituminous pavement or floors and as elsewhere specified or indicated on the plans shall be approved bank-run sand or compacted graded aggregate free from large stones and containing not more than ten percent (10%) by weight of loam or clay. This backfill shall be compacted to ninety-five percent (95%) as determined by the Standard Proctor test from pipe bedding to one foot above the pipe, and the remainder of the trench up to the concrete trench cap shall be compacted to one hundred percent (100%) as determined by the Standard Proctor test. Mechanical vibrating equipment shall be used to achieve the required compaction.
- 3.) Backfill under gravel or crushed stone surfaced roadways and surface treated type bituminous roadways shall be the approved suitable excavated material placed as described above for the full depth and width of the trench. Backfill shall be free from large stones and contain not more than ten percent (10%) by weight of loam or clay. This backfill shall be compacted to ninety-five percent (95%) as determined by the Standard Proctor test from pipe bedding to one foot above the pipe, and the remainder of the trench shall be compacted to one hundred percent (100%) as determined by the Standard Proctor test. Mechanical vibrating equipment shall be used to achieve the required compaction.
- 4.) Backfill in unpaved areas shall be compacted with mechanical vibrating equipment to ninety percent (98%) as determined by the Standard Proctor Test. Backfill material from pipe bedding to ground surface shall be excavated earth free from large stones and other debris.
- 5.) Where sheeting is used in connection with the work, it is in no case to be withdrawn before the trench is sufficiently filled to prevent damage to banks, road surfaces, adjacent pipes, adjacent structures or property. When the removal of sheeting endangers adjoining improvements, it will be left in place.
- 6.) All costs of compaction testing shall be the responsibility of the Developer.

## **509. THRUST RESTRAINT FOR PRESSURE LINES**

### **1.) Reaction Blocking**

- a.) Underground piping laid around curves and at all unsupported changes of direction, all tees, wyes, crosses, plugs and other like fittings shall be solidly and properly blocked with high early strength concrete against solid earth to take the reaction of the main pressure and to prevent lateral movement of the pipe or fittings when under pressure. Concrete for reaction blocking shall be Class A concrete and shall have a minimum compressive strength of 3,000 psi at twenty-eight (28) days. The Contractor shall allow the concrete to set up for a minimum of four hours before backfilling. The blocking, unless otherwise shown, shall be so placed that the pipe and fitting joints will be accessible for repair.

- b.) Reaction blocking shall be constructed in conformance with the Standard Detail Drawings for Reaction Blocking. Prior to blocking any joint or fitting with concrete, that joint or fitting shall be wrapped with polyethylene film in such a manner that the concrete will not stick directly to the fitting, but that the load bearing capacity of the blocking will not be affected.
- c.) The sizing of the thrust block bearing area given in the detailed drawings is based on a soil strength of 2000 PSF and a water pressure of 250 PSI. The Design Professional preparing the water main design shall verify the soil conditions before the thrust block design is implemented.

## 2.) **Retainer Glands**

Mechanical joint fittings and valves on Ductile Iron Pipe shall be installed with retainer glands where specified herein.

## 3.) **Rodding / Straps**

Where blocking cannot be poured against undisturbed earth, the Contractor shall pour concrete deadmen with threaded rods and/or metal straps coming out of the deadman and connecting to the valve/fitting for restraint. The rods and metal straps shall be coated with an approved bitumastic coating prior to backfilling. Vertical bends shall be restrained with threaded rods and concrete deadmen as shown in the detailed drawings (**Section 800**).

## 4.) **Restrained Joints**

Where approved by the Authority, another option to using concrete blocking in restricted areas is the use of restrained joints. Restrained joints shall be provided where specified on the approved plans and shall be of the type specified in the Section 400 of these specifications. Assembly shall be in accordance with the manufacturer's recommendations. While the typical bedding required for water mains is Type 3, all restrained pipe and bends shall have Type 4 bedding.

## **510. SETTING FIRE HYDRANTS**

Fire hydrants shall be placed at the locations shown on the plans and installed in accordance with AWWA MI, Chapter 4. Gate valves for fire hydrants shall be connected directly to the main by means of a "Locked Hydrant Tee". All other connections between the main and the fire hydrant shall be mechanical joint with ductile iron retainer glands. Fittings shall be restrained by a "Locked Hydrant Adapter" whenever the fire hydrant is located close enough to the main to allow its use. Not less than four cubic feet of No.5 or No.57 stone shall be placed around the base of the hydrants, as shown in the Standard Detail Drawings. Before placing the hydrants, care shall be taken to see that all foreign material is removed from within the body. The stuffing boxes shall be tightened and the hydrant valve opened and closed to see that all parts are in first class working condition. All hydrant openings shall be kept capped, except when hydrant is being worked on.

When a fire hydrant has been constructed but is not yet in service, the Contractor shall provide and attach to the fire hydrant a flag or collar indicating that the fire hydrant is not in service. Said flags or collars shall remain on the fire hydrant until it is put into service. Whenever an existing fire hydrant is taken out of service, whether temporarily or permanently, it shall be equipped with a flag or collar indicating that it is not in service. The Contractor shall provide and install flags or collars as required and shall notify the Fire Department whenever the operating status of any fire hydrant changes.

FIRE HYDRANTS SHALL NOT BE OPERATED WITH ANY TOOL EXCEPT A SPECIFICALLY DESIGNED FIRE HYDRANT WRENCH. If the Contractor observes any other contractor or person operating a fire hydrant with an unapproved fire hydrant wrench, he shall report that fact to the Authority immediately. It is the Contractor's responsibility to insure that all new facilities are maintained in new condition until final completion of the project and acceptance by the Authority. Fire hydrants with damaged operating nuts shall not be accepted.

## **511. SETTING VALVES AND FITTINGS**

Valves and fittings shall be placed where shown on the plans. Valves shall be set plumb, and shall have cast iron valve boxes. The valve boxes shall be placed directly over the valve and set plumb, the top of the box being brought to the surface of the ground. After the boxes are in place, earth shall be filled in the trench and thoroughly tamped around the box. After all settlement has taken place, a concrete collar shall be constructed for each valve box.

Fittings shall be properly braced to insure that they will not be blown off or broken loose under the greatest possible working pressure. All fittings shall be mechanical joint unless specified otherwise. In situations where there is insufficient undisturbed earth to act as a bearing surface or where otherwise directed by the Authority, fittings shall be restrained by the use of threaded rods or other method acceptable to the Authority. Line valves shall be supported and restrained by concrete blocking and threaded rods as shown in the detailed drawings.

Valve stem extensions shall be installed where the valve operating nut is more than three feet below the finished grade. The valve stem extension shall be of sufficient length to place its operating nut at a depth between two and three feet below finished grade.

## **512. MARKING LOCATION OF VALVES AND THE END OF THE MAIN**

- 1.) Each main line water valve shall be marked by cutting a letter "V" in the curb. The "V" shall be turned to point toward the valve. The letter height shall be 6".
- 2.) Concrete valve markers shall be set for main line water valves with an even number of feet between the center line of the valve and the center line of the aluminum disc in the top of the marker, and the distance in feet between the valve and marker shall be stamped in the marker at the time of setting.
- 3.) A concrete valve marker shall be placed directly over the end of any water main stubbed out for future use or any dead end main. The letters "EOL" shall be cast into the top of the marker or stamped into the aluminum disc in the top of the marker.

## **513. PLACING OF STEEL CASING PIPE**

- 1.) Casing pipe shall be installed at the locations required by the Authority. Unless directed otherwise, the installation procedure shall be the dry bore method. The hole is to be mechanically bored and cased through the soil by a cutting head on a continuous auger mounted inside the casing pipe. The installation of the casing and boring of the hole shall be done simultaneously by jacking. Lengths of casing are to be full circumference butt-welded to the preceding section installed. Excavation material will be removed and placed at the top of the working pit.
- 2.) Jacks for forcing the casing pipe through the roadbed shall have a jacking head constructed in such a manner as to apply uniform pressure around the ring of the pipe. The casing to be jacked shall be set on guides, braced together, to properly support the section of the pipe and direct it to the proper line and grade. In general, roadbed material shall be excavated just ahead of the pipe, the excavated material removed through the pipe, and the pipe then forced through the roadbed into the excavated space.

- 3.) Where pipe is required to be installed under railroads, highways, streets or other facilities by jacking or boring methods, construction shall be done in a manner that will not interfere with the operation of the facility, and shall not weaken the roadbed or structure.
- 4.) The use of water or other fluids in connection with the boring operation will be permitted only to the extent necessary to lubricate cuttings. Jetting will not be permitted.
- 5.) The diameter of the excavation shall conform to the outside diameter and circumference of the casing pipe as closely as practicable. Any voids which develop during the installation operation shall be pressure grouted.
- 6.) The casing shall be jacked from the low or downstream end. At each end of the casing pipe the void between the carrier pipe and casing shall be sealed with brick and mortar. Any pipe damaged in jacking operations shall be removed, and replaced by the Contractor at their expense.
- 7.) After the steel casing pipe has been installed, the DIP carrier pipe shall be installed in the casing pipe. Care shall be exercised at all times to protect the coating and lining of this pipe and to maintain tight, full-seated joints in the carrier pipe. Where the carrier pipe is 24" in diameter or less, joint gaskets shall be "Field-Lok" gaskets or approved equal inside of the casing.

#### **514. CONNECTION TO THE EXISTING AUTHORITY WATER SYSTEM**

- 1.) The developer's private contractor shall make all required connections and taps to the Authority's water system. The Authority's Inspector will supervise the tap and all associated work. The contractor shall give the Authority a minimum of (4) days notice prior to any tap on the CCWSA'S water system.
- 2.) The Contractor will provide proper traffic control devices and certified personnel to direct traffic if required.
- 3.) All taps shall be wet taps (on pressurized water mains in service). All taps shall be made with saddles or tapping sleeves.

## **515. INTERRUPTION OF WATER SUPPLY DURING CONSTRUCTION**

No interruptions of water service will be allowed without the permission and supervision of Authority personnel. Residents and building occupants shall be informed of the date, time of cutoff and the duration of stoppage. Failure to do so will make the Contractor liable for any damages reported to the Authority's Office. Four (4) days notice shall be prepared and given to the affected customers and must be coordinated with Authority. When it is necessary to schedule a water outage for any construction, signs must be posted at least four (4) days in advance to notify the public. In some cases, the water outage may need to be scheduled for nights or weekends to lessen the inconvenience to businesses or schools. **(See Detail No. W721 for sign requirements).** These signs are to be provided and installed by the Developer.)

## **516. RAILROAD CROSSINGS**

All railroad crossings shall conform to the requirements of the American Railway Engineering Association Manual for Railway Engineering. The Contractor shall secure permission from the railroads to schedule the work so as not to interfere with the operation of the railroads. The Contractor shall be held responsible for any delays or damages occurring to the railroads. The Contractor will furnish the railroad with such additional insurance as may be required, cost of same to be borne by the Contractor, together with the costs for flagmen, watchmen, temporary work of any nature, safety devices and any other items that may be imposed by the railroad.

## **517. HIGHWAY CROSSINGS**

- 1.) The Contractor shall be responsible for coordinating and scheduling all construction work in the Georgia State Highway right-of-way with the Georgia Department of Transportation.
- 2.) Work along and across Georgia State Highway right-of-way shall conform to Georgia D.O.T. Standard Specifications for Construction of Roads and Bridges. The Developer is required to obtain all necessary permits.
- 3.) Traffic control within the Georgia State Highway right-of-way shall comply with Section 107.09 of the State of Georgia D.O.T. Standard Construction Specifications, or Sections 104.05 and 107.07 of the U.S. Manual On Uniform Traffic Control Devices For Streets and Highways, latest editions.



## 518. STREAM CROSSINGS

Crossing streams shall be done in compliance with the Federal, State and Local laws and permit requirements. The methods described below are subject to change due to more recent regulations implemented by the varying government agencies. The Developer is liable for knowing and complying with the most stringent regulations in force at the time of construction.

- 1.) The suggested method of crossing a river, stream, creek, impoundments, or wet weather ditch is with a bore under the creek or river with a minimum of three feet (3') of cover between the lowest point in the stream and the top of outside diameter of the casing. Casings and ductile iron pipe are required for all stream crossings and shall extend a minimum of twenty feet (20') beyond the vegetative buffer (State or County buffer, whichever is wider) on each side. An open cut of the stream is allowable if no endangered species are affected and if the Developer obtains permission from the various governing agencies. If the stream is open cut, concrete collars or encasement must be provided at all joints for ductile iron pipe with less than three feet (3') of cover.
- 2.) Design engineer is responsible for checking and designing against floatation.
- 3.) The stream bed and sides at the crossing site shall be protected from erosion in accordance with the **Manual For Erosion and Sediment Control In Georgia**, 2000 or most current edition.
- 4.) Where streams are allowed to be open cut, the construction in stream beds shall follow the following guidelines:
  - a.) Construction in and around stream beds must adhere to the current regulations of the Georgia EPD, the Corps of Engineers, Cherokee County and the U.S. Department of Fish and Wildlife. The design engineer and contractor are responsible for knowing and complying with these regulations. Any item published within these specifications that is in conflict with stream bed protection regulations is hereby deemed invalid, unless the specification herein is considered more stringent by the reviewing agency.
  - b.) Fording of live streams with construction equipment will not be permitted, unless specifically approved in writing. Unless otherwise approved in writing, mechanized equipment shall not be operated in live streams except as may be required to construct temporary diversion structures, and temporary or permanent structures.
  - c.) Erosion control measures shall be installed prior to performing any stream crossings. All work should be performed when stream flows are at their lowest, and all work should be performed as quickly and safely as possible. As soon as conditions permit, the stream bed shall be cleared of all falsework, debris, and other obstructions placed therein or caused by the construction operations.

- d.) Erosion control measures can include, but is not limited to, the following items:
  - a.) Silt fencing, two rows of type C.
  - b.) Erosion control checkdams.
  - c.) Channel diversion through temporary storm drain pipe.
  - d.) Rock filter dams.
  - e.) River Stone in the creek bed.
  - f.) Geotextiles for stream bank restoration.
  - g.) Special vegetative installations.

The construction and installation of these various structures are detailed in the **Manual For Erosion And Sedimentation Control In Georgia** or the Georgia Department of Transportation Standards and Construction Details, both of which are available for purchase by the Contractor. All measures must be approved by the NRCS and the EPD.

## **519. REPLACEMENT OF PAVEMENT**

### **1.) General**

Contractor shall fully restore and replace all pavement, curbs, gutters, sidewalks and other surface structures removed or disturbed, to a condition that is equal to or better than the original condition in a manner satisfactory to the Authority.

Contractors which are utilizing the roadway shoulders for construction are required to stabilize the earth shoulders every three days as a maximum time period. They are required to stabilize the shoulder before leaving the work area on any particular day if rain is forecast within the next 24 hours.

### **2.) Pavement Cuts**

- a.) All paved roads will be bored and cased. A bore must be attempted before consideration will be given to cutting the street.
- b.) Existing roadways shall not be open cut unless permission is granted by the Georgia D.O.T., Cherokee County Engineering Department (CCED) or City. Submittal of an authorization letter from the D.O.T. or the CCED is required.
- c.) One lane of traffic shall be maintained open at all times. Construction work shall be limited to time between 9 A.M. and 4 P.M.
- d.) The Contractor shall furnish traffic control devices and certified personnel to direct traffic, if required.

- e.) The above requirements may be altered with the written approval of the CCED in extenuating circumstances.
- f.) Assuming that a road bore has been attempted and failed, or that the Developer has received permission to open cut a road, pavement replacement shall meet the current specifications as required by the City, Cherokee County or Georgia D.O.T.
- g.) The Contractor shall adhere to the Georgia D.O.T. Specifications for the Installation of Safety Barricades, Section 107.09 during construction in the roadway or shoulder.
- h.) Where possible, all pipe under existing paved driveways will be either free bored or installed in casing.

## **520. LOCATION AND PROTECTION OF EXISTING UNDERGROUND UTILITIES**

It is the responsibility of the Contractor to locate and protect all underground utilities and structures. No utility or structure is to be moved or disturbed without the approval of the utility company or the Owner of the structure. Any damage caused by waterline installation to any utility or structure shall be immediately reported to the Chief Inspector of the CCWSA and repaired at the Contractor's expense.

During construction and after the water main is operational and throughout the one year maintenance period, the Developer will be responsible for locating all water and sewer facilities when called upon by the Utilities Protection Center or the Authority. These utilities must be marked within 72 hours of the time notified. Any water or sewer facilities cut by others will be repaired by the Developer's contractor at the Developer's expense if the lines are not located or if they are improperly located. The Developer shall provide the name and telephone number of the company providing this locate service for the Developer.

## **521. CLEAN-UP**

- 1.) The Contractor shall remove all unused material, excess rock and earth, and all other debris from the construction site as closely behind the work as practical. If the Contractor fails to maintain clean-up responsibilities as directed by the Authority's representative, the Authority may choose to use their own forces to do so, followed by an invoice to the Developer for the Authority's work.
- 2.) All trenches shall be backfilled and tamped before the end of each days work.

3.) Prior to requesting the "completion of water main construction" inspection, the Contractor shall do the following:

- a.) Remove and dispose of in an acceptable manner all shipping timbers, shipping bands, spacers, excess materials, broken material, crates, boxes and any other material brought to the job site.
- b.) Repair or replace any work, trees, lawns, shrubs, fences, flower beds, drainage culverts or other property damaged by the water line construction. All items damaged beyond repair shall be replaced with the same kind of material as existed prior to the damage occurring.
- c.) Insure that all valves have been located and are fully open. Adjust all valve boxes to grade and pour concrete collars around all valve boxes outside paved areas.
- d.) Insure that fire hydrants are set to grade and that connections are open.
- e.) All easement areas shall be cleared of trees, stumps and other debris and left in a condition such that the easement can be maintained by bush-hog equipment.
- f.) All shoulders, ditches, culverts, and other areas impacted by the water main construction shall be at the proper grades and smooth in appearance.

## **522. GRASSING**

A uniform stand of grass or mulch for erosion protection is required over all road shoulders and water main easements prior to the Authority's acceptance of the water main. Grass shall be as defined and planted in conformity with the Temporary and Permanent Disturbed Area Stabilization of the **Manual for Erosion and Sediment Control in Georgia**, 2000 or most current edition.

Grass seed shall be selected based on the type of seed suitable to the area and season of year. Refer to the **Manual for Erosion and Sediment Control in Georgia** for grass growing schedule, selection of grass seed, fertilizers, lime, inoculants, mulching, etc.

The Contractor shall provide water for irrigation from the nearest available metered source. The soil must be thoroughly wet to a depth that will insure germination of the seed. Water must be applied at a rate not causing runoff or erosion.

Growth and coverage on areas grassed shall be considered in reasonably close conformity with the intent of this requirement when a viable stand of grass covers at least 98% of the total area with no bare spots exceeding one (1) square foot and the ground surface is fully stabilized against erosion. The Contractor shall repeat all work, including plowing, fertilizing, watering, and seeding as necessary to produce a satisfactory stand.

The Contractor or Developer shall do all maintenance work necessary to keep all planted areas in satisfactory condition until the work is finally accepted. This shall include mowing, repairing washes that occur, reseeding, and water as required to produce a healthy and growing stand of grass. Mowing will be required to remove tall and obnoxious weeds before they go to seed.

### **523. STANDARD DETAILED DRAWINGS**

Installation of fire hydrants, water valves, valve boxes, meters, long side services, water lines, etc. shall be made in accordance with the Standard Detailed Drawings in these specifications.

### **524. BARRICADES**

The Contractor shall provide, erect and maintain all necessary barricades, suitable and sufficient red lights, danger signals and necessary precautions for the protection of the work and the safety of the public. Streets closed to traffic shall be protected by effective barricades on which shall be placed acceptable warning signs. Barricades shall extend completely across the street which is to be closed, and shall be illuminated at night by lights not farther than (5) feet apart, and lights shall be kept burning from sunset to sunrise.

### **525. FENCES**

On water line extensions to the development, the Contractor shall take down fences on or crossing right-of-way for such periods of time only as are necessary to prosecute the work of clearing, grubbing, trenching, pipe laying and backfilling. Gaps made in fences shall be closed in a substantial manner at night and during any suspension of work, and, upon completion of the pipe line, fences shall be restored to as good condition as before disturbed.

### **526. RIP-RAP**

Where required, stone rip-rap shall be dumped and hand placed to form a compact layer. Stone rip-rap shall be placed to a thickness of not less than 8" and not more than 18", to the length and width shown on the plan or as directed by the Inspector. Rip Rap shall have a geotextile underliner between the soil and the stone.

# SECTION 600 – WATER LINE INSPECTION, TESTING AND ACCEPTANCE

## 601. INSPECTION

- 1.) Inspection will be done by the Cherokee County Water and Sewerage Authority. Inspections will be scheduled as received by the Authority.
- 2.) The Chief Inspector shall be notified when specific inspections are required so that the inspection time can be scheduled.
- 3.) The contractor shall present the following when requesting a final project inspection:
  - a.) The size and length of all lines installed including services.
  - b.) A completed Project Information Form (Exhibit B) (See form at end of Section 600.)
  - c.) As-built plans and electronic data prepared in accordance with the requirements set forth in **Section 605**.
- 4.) In no circumstances shall any buildings and plumbing fixtures be connected to the main until the main is inspected and approved by the Authority.
- 5.) Upon request, the contractor shall furnish the Inspector with appropriate copies of the manufacturer's certification that the materials to be used meet the materials requirements of these specifications. The Inspector may reject any materials not meeting specifications or any faulty or damaged materials. Any materials so rejected must be removed from the project immediately and must be prominently marked so that they can be spotted on this or any other project.
- 6.) Authorized representatives of the Cherokee County Water and Sewerage Authority, which may include appropriate county, state or federal agencies, shall have access to the site for inspection at any time.
- 7.) The Chief Inspector shall be notified by 8:30 A.M. of each workday when work is scheduled unless authorized otherwise.
- 8.) The Inspector may at any time direct that he/she be allowed to see any pipe work, bedding, fire hydrant, tee, valve or other appurtenance. If the Chief Inspector so directs, all pipe work shall be left open until the Inspector views the work. The trench may be backfilled with the approval of the Inspector if the work is not inspected by the close of the working day. No valves, fire hydrants, tees, thrust blocking or lot services shall be backfilled without the approval of the Inspector.

- 9.) The Contractor shall complete the project and shall have cleaned up the job site prior to requesting a final project inspection. The Chief Inspector may terminate the inspection and direct further work at any time he feels that the project is not substantially complete and ready for inspection. The Contractor shall furnish adequate personnel to check for open valves and give assistance needed by the Chief Inspector.
- 10.) The representative of the Chief Inspector will normally visually inspect all water lines and appurtenances for conformance to the specifications and will check the measurements shown on the "As-Builts" for accuracy. The representative will perform pressure and leakage tests to insure all lines are watertight. The representative shall also supervise a disinfection test. Any of the following tests may also be required at the discretion of the Inspector:
- a.) Fire Hydrant / Hammer Test (**See Section 403**)
  - b.) Trench compaction tests

Any defects found by these tests must be corrected before construction of the project may proceed.

- 11.) A punch list shall be issued for corrective work if needed. However, the Chief Inspector shall not perform the contractor's work by finding all of his problems before the project is reasonably complete.

## **602. COMPACTION TESTING**

All trenches shall be subject to compaction testing after backfilling and shall meet the compaction requirements set forth in **Section 508**. All trenches failing to meet compaction requirements shall be excavated and recompacted and retested. This process shall continue until a passing test is achieved. All costs of compaction testing shall be the responsibility of the Developer.

## **603. FIRE HYDRANT AND VALVE TESTING**

All fire hydrants shall be tested per **Section 403** and flushed to check the operation of the hydrant. All valves shall be located and their operation checked. All valves shall be left fully open.



## **604. WATER SYSTEM TESTING**

### **General**

All lines designed to operate under pressure shall be successfully tested. Tests of installed piping shall consist of a pressure and leakage test and a disinfection test.

All piping to be tested must satisfactorily comply with these tests before being eligible for acceptance. In general, tests shall be conducted in accordance with AWWA C600 and C651 except as otherwise herein specified.

### **1.) Pressure and Leakage Testing**

- a.) After all piping has been placed, each section between line valves shall be tested by the Developer's Contractor in the presence of the Chief Inspector or his designated representative and tests shall be continued until all leaks have been made tight to the satisfaction of the Authority. The Contractor shall furnish all necessary meters, pumps, gauges, bulkheads, and other materials and appliances necessary to conduct the test as herein required. Every precaution must be taken to valve-off or otherwise protect control equipment in or attached to the pipe line to prevent damage thereto.
- b.) Before applying the specified test pressure, all air shall be expelled from the pipe. If hydrants, blow-offs or air release valves are not available at the high places, the Contractor shall make the necessary taps at points of highest elevation before the test is made and insert plugs before the test has been completed.
- c.) Prior to the pressure test, pipe laid in trenches shall be backfilled adequately to secure the pipe during the test. Any observed leakage shall require corrective measures to pipe lines and/or joints to the satisfaction of the Inspector.
- d.) The Authority will furnish the necessary water for testing and disinfection of the lines; however, any water lost through breakage of lines or unnecessary or excessive flushing of lines will be charged to the Contractor at the current residential rate. All lines shall be tested to a pressure of 1.5 times the working pressure at the lowest point of the system to be tested. Test duration shall be two (2) hours. However, test pressure shall not exceed pipe, valve and/or thrust-restraint design pressures. The Chief Inspector or his representative may require a twenty-four (24) hour test if he so desires. Test pressure shall not vary by more than  $\pm 5$  psi for the duration of the test which may require periodic pumping (in which case the added water will be counted as part of the leakage). Lines shall be tested in sections between the valves. The rate of leakage shall not exceed 13.5 gallons per 24 hours per inch diameter per mile of water main. (See Table below.)

## LEAKAGE TABULATION

<u>SIZE OF PIPE</u>	<u>GALLONS/HOUR/100 FT.</u>	<u>GALLONS/DAY/100 FT.</u>
16"	.171	4.091
12"	.128	3.068
10"	.107	2.557
8"	.085	2.046
6"	.064	1.534

**Any section of the line not meeting the above test shall have the leaks found and corrected at once and re-tested until the leakage falls within the limits specified above. Leakage testing must be witnessed and approved by the Authority.**

### **2.) Disinfection**

After leakage testing and all necessary repairs have been made, the Contractor shall flush and disinfect all potable water mains and equipment installed in strict accordance with AWWA Standard for Disinfecting Water Mains, C651, latest revision, subject to the following special conditions:

- a.) The method of disinfection shall be the Continuous - Feed Method as per AWWA C651, latest revision, Section 4.4.3. Care shall be taken in filling the mains so that extrained air is drawn from the pipes at all high points so as to permit intimate contact of the disinfection agent with the entire inside surface of the pipe and appurtenances. The potable water shall be chlorinated so that after a 24 hour holding period in the main, there will be a free chlorine residual of not less than 10 mg/L at all points in the system when tested with a standard orthotolindine solution.
  
- b.) The form of chlorine shall be a 1 percent solution made from either sodium hypochlorite or calcium hypochlorite which shall be measured and pumped into the pipeline. Water must be flowing during the feeding operation and the injection point must be located so that the flow of water will disperse the chlorine throughout the pipeline. AWWA C651 requires the injection point be located at a point not more than 10 feet from the point of connection to the existing water supply. The chlorine should be fed at a constant rate such that the water will have not less than 25 mg/L free chlorine. The table below gives the amount of chlorine required for each 100 feet of pipe of various diameters to produce a 25 mg/L concentration.

## Chlorination Tabulation

<u>Pipe Diameter (in.)</u>	<u>100% Chlorine (lb.)</u>	<u>1% Chlorine Solution (gal.)</u>
6	0.030	0.36
8	0.054	0.65
10	0.085	1.02
12	0.120	1.44
16	0.217	2.60

- c.) After 24 hours, the line shall be flushed until the chlorine content is not more than 2.0 parts per million. When this step is completed, the Developer will notify the Authority so as to schedule the taking of the water sample for the bacteria test. If the samples show evidence of contamination upon testing, the above procedure of disinfection shall be repeated until approved samples are obtained. No connections shall be made to the existing system until all of the samples have been tested and approved by the Chief Inspector. The Developer may be required to add additional taps for bleeding purposes at the ends of water mains or wherever necessary for taking samples.
- d.) The Contractor shall dechlorinate the highly-chlorinated water being flushed from the water main to open areas where the discharge will not damage the roadbed or adjacent property.

The chlorine residual of water being disposed may be neutralized by treating the water with one of the chemicals listed in the table below:

### Chemical Required

Residual Chlorine Concentration mg/L	Sulfur Dioxide (SO <sub>2</sub> )		Sodium Bisulfite (NaHSO <sub>3</sub> )		Sodium Sulfite (Na <sub>2</sub> SO <sub>3</sub> )		Sodium Thiosulfate (Na <sub>2</sub> S <sub>2</sub> O <sub>3</sub> ·5H <sub>2</sub> O)	
	lb	(kg)	lb	(kg)	lb	(kg)	lb	(kg)
1	0.8	(.36)	1.2	(.54)	1.4	(.64)	1.2	(.54)
2	1.7	(.77)	2.5	(1.13)	2.9	(1.32)	2.4	(1.09)
10	8.3	(3.76)	12.5	(5.67)	14.6	(6.62)	12.0	(5.44)
50	41.7	(18.91)	62.6	(28.39)	73.0	(33.11)	60.0	(27.22)

Amounts of chemicals required to neutralize various residual chlorine concentrations in 100,000 gal (378.5 m<sup>3</sup>) of water.

## 605. "AS-BUILT" RECORD DRAWINGS

At the completion of the water line installation and when requesting the final project inspection, the Authority's GPS Coordinator shall receive from the Contractor three sets of printed as-built plans and electronic data prepared in accordance with the following requirements:

- 1.) Attached to the As-Builts shall be a completed Project Information Form (Exhibit B), which includes the name of the project, the project location, the Developer's name and telephone number, the Contractor's name and telephone number, the street names, the water main size for each street, the length of the water main for each street, the pipe material used on each street, the cost of the water facilities for each street, and the work start date and work completion date for each street.
- 2.) Three (4) sets of "As-Built" plans shall be submitted to the Authority's GPS Coordinator. The plans shall show all water information "As-Built" in the field and any field changes made to the approved plans. In the event "As-Builts" cannot be made available at the completion of the line, the General Manager may authorize the continuation of the construction; however, the final inspection cannot be conducted and the conditional approval letter cannot be written until "As-Builts" are received. In the event that the designer does not perform the field staking, the contractor must furnish certification from a licensed engineer or surveyor attesting to the accuracy of all as-built information presented. This certification and the certification of the engineer / land surveyor preparing the "As-Builts" must be shown on the drawings. "As-built" drawings shall include a site plan, plan and profile sheets, and any supplementary drawings and shop drawings. Stationing of the water main alignment and the various water system appurtenances shall be required on the "As-Builts" as well as the construction drawings along with the Point I.D. The "As-Built" drawings shall meet the same requirements as the plans for review. The printed version of the As-Built water plan shall show the correct location and Point I.D. of water mains at all transitions (vertical and horizontal) at (50' intervals along County, State or Federal road ways), fire hydrants, fittings, tap location(s), valves, meters, and lot services.

As-Built plans shall be submitted on 22" x 34" drawing sheets and shall be submitted concurrently in an "AutoCAD" drawing electronic format. The monumentation and the calculations used to reference and determine the coordinate system for locations shall be supplied at the same time that As-Built plans are submitted. As-Built information for utility locations shall be shown on plans and submitted in ASCII text electronic format for each point.

Horizontal locations shall be referenced to Georgia State Plane Coordinates (West Zone feet). Vertical locations shall be shown referenced to Mean Sea Level. Reference all horizontal locations to the NAD83/94 (latest adjustment) datum and reference all vertical locations to the NAVD88 datum. All orthometric locations shall be referenced to

Geoid 99/03. All points shall be verifiable by the Cherokee County Water & Sewerage Authority control network. All Horizontal and Vertical locations shall have no translation, rotation or angle adjustment. All points are subject to verification by the Cherokee County Water & Sewerage Authority.

The information submitted electronically for water mains, including correct locations of the water main, Point I.D. of water mains at all transitions (vertical and horizontal) at (50' intervals along County, State or Federal road ways), fire hydrants, valves, fittings, main line taps, master meters, and fire line meters, shall include:

- a.) Point ID (see CCWSA staff)
- b.) Northing
- c.) Easting
- d.) Ground Elevation
- e.) Top of Pipe, Valve or Hydrant Elevation  
Point Description (Pipe, Fitting or Valve Type and Size)

The following are specific guidelines for the preparation of the printed version of the "as-built" drawings:

- a.) Water "As-Built" shall be a separate plan.
  - b.) No contour lines.
  - c.) Location of service, meter and backflow preventer should be shown.
  - d.) Road names shall be on plans.
  - e.) The center of all fire hydrants shall be located horizontally and vertically as described above.
  - f.) All lots are to be numbered.
  - g.) Printed "As-Builts" are to be clear and legible.
  - h.) Roads shall be shown on all plans.
  - i.) "As-Built" is to be in large clear print on plans.
  - j.) Drawings sheet shall be no larger than 24" x 36".
  - k.) Scale no larger than 1"=20', no smaller than 1"=100' for cross-country lines and 1"=50' for congested areas.
  - l.) When a phase of a subdivision is completed, a location sketch of the entire
  - m.) Ground water and solid rock encountered during construction will be noted on "As-Builts".
  - n.) Water point I.D.'s (Valve I.D., Water Main points, etc...) shall be on plans, electronic data and ASCII or EXCEL data file. All point I.D.'s shall correspond.
- 3.) As-Built water plans for commercial, multi-family, school and industrial sites shall show the following at a minimum scale of 1" = 100':
- a.) Location, size and elevation of all existing and proposed water, sanitary sewer, and fire lines and of any easements required.
  - b.) Location and size of all fire mains and location of all fire hydrants.
  - c.) Location, size and number of dwelling units and buildings.

- 4.) The As-Builts must be printed from the AutoCAD files supplied to the Authority concurrently with the As-Builts. These plans shall have been corrected to show all field changes made to the approved drawings. Hand marked copies prepared by the contractor will not be accepted for "As-Builts".
- 5.) As-Built drawings shall include the site plan, construction plan sheets, and any supplementary drawings and shop drawings. Plan of fire meters or detector meters should be shown if applicable. "As-Builts" is to be stamped in large clear print on plans.
- 6.) The Authority shall have the right to withhold water meters until the "As-Builts" have been submitted as required.
- 7.) Final Plat and or Final Plans will not be approved or signed by the Authority until "As-Builts", easement drawing and easement agreements have been completed and submitted to the Authority.

## **606. ACCEPTANCE**

Please refer to the following CCWSA Maintenance Bond/Letter of Credit Administrative Policy for the procedures related to the final approval and acceptance of water and sanitary sewer facilities:

# Cherokee County Water and Sewerage Authority

## Maintenance Bond/Letter of Credit

### Administrative Policy and Procedures

#### **General**

- All new developments must submit to the Authority a maintenance bond or letter of credit prior to approval of the final plat for residential developments or the acceptance of the as-built drawings for all other developments.
- Once the water and sewer infrastructure is in place and approved, the Developer must submit a maintenance bond or letter of credit in a form acceptable to CCWSA staff, prior to the Authority's approval of the Final Plat or As-Built plans.
- The maintenance bond or letter of credit **amount** will be generally determined by the linear feet of water and linear feet of sewer infrastructure within the development.
- Maintenance bonds or letters of credit shall be for a period of twelve (12) months from the receipt of Final Plat approval for residential developments or acceptance of as-built drawings for all other developments.

#### **Approval of Infrastructure for Final Plat Recording**

- 1) Upon the completion of the water and/or sewer construction, the Developer shall contact the CCWSA's Inspector requesting a final inspection of infrastructure.
- 2) If the Authority's Inspector finds, upon inspection, that all infrastructures meet the requirements of CCWSA, he/she shall provide written notice of acceptance to the Developer.
- 3) If the CCWSA's Inspector finds, upon inspection, that infrastructures do not meet the requirements of CCWSA, the Authority shall provide the Developer with written notice detailing the reasons for rejections of the infrastructure.
- 4) Once the CCWSA's Inspector finds that all infrastructures meet the requirements of CCWSA, the inspector shall require the Developer to post maintenance bond or letter of credit.
- 5) Once a maintenance bond or letter of credit has been posted, the Authority's Inspector will approve the Final Plat for residential developments or accept the as-built drawings for all other developments.
- 6) Final plat will not be signed or as-built drawings will not be accepted until a satisfactory maintenance bond or letter of credit has been posted.

**No Exceptions.**

### **Maintenance Bond/Letter of Credit Amount**

- 1) The maintenance bond or letter of credit amount will be determined generally by the linear footage of water line and/or the linear footage of sewer line within the development.
- 2) Per foot amount will be determined by the CCWSA staff taking into account the current economic climate as well as the cost of materials, labor and fuel.
- 3) The minimum maintenance bond and/or letter of credit amount required for a development shall be five thousand dollars (\$5000.00) for water and five thousand dollars (\$5000.00) for sewer.

### **Approval of Water and Sewer System for Authority Acceptance**

- 1) The twelve-month maintenance period will allow the CCWSA's Inspector to assure compliance with CCWSA development specifications. The developer shall be required to contact the CCWSA's Inspector in writing at the end of the nine (9) month period to initiate the CCWSA's punch list.
- 2) The CCWSA's Inspector shall prepare a single punch list to the Developer affording it a 60-day period in which to make all necessary repairs. The Developer shall be required to contact the CCWSA's Inspector in writing at the end of the 60-day period after all punch list items have been completed. The CCWSA's Inspector shall have 30 days to make its final review for approval and shall notify the Developer in writing of the results of this inspection. An extension of the bond may be granted at the discretion of the CCWSA's General Manager. Developer shall pay for any additional inspections required by the Developers failure to complete punch list items prior to final approval.
- 3) If any punch list items are not completed by the Developer within the specified period of time or extensions the maintenance bond or letter of credit shall be utilized to pay for the full cost of the repairs. Should the amount of the maintenance bond or letter of credit be inadequate to pay for the full cost of the repairs, CCWSA shall have the authority to collect the remaining amount from the developer.

### **Official Acceptance/Release of Bond or Letter of Credit**

- 1) At the time that the work is inspected and found free from defects, the Authority's Inspector shall provide the Developer with written "Final Approval" for the acceptance of the water and sewer infrastructure.
- 2) Upon the issuance of final approval, the CCWSA shall release the Maintenance bond or letter of credit.



### **Lift Station Maintenance Bond**

- 1) All new subdivisions or commercial developments that include wastewater lift station(s) will be required to post a maintenance bond or letter of credit for each lift station.
- 2) The amount of the maintenance bond or letter of credit will be in amount as determined by CCWSA staff.
- 3) The maintenance bond or letter of credit will be for a twelve month (12) period from the date of acceptance a limited warranty deed for the fee simple ownership of the real property upon which the pump station is constructed.
- 4) The maintenance bond or letter of credit will be released following the expiration of the twelve (12) month maintenance period and upon final inspection and final approval of the lift station.
- 5) The Developer shall provide a detailed construction cost report to the CCWSA upon completion of construction of any lift station prior to the acceptance of as-built drawings.

**EXHIBIT "B"**  
**Cherokee County Water & Sewerage Authority**  
**PROJECT INFORMATION FORM**  
**WATER SYSTEM FACILITIES**

Project Name: \_\_\_\_\_

Location: \_\_\_\_\_

Developer: \_\_\_\_\_ Phone No: (\_\_\_\_) \_\_\_\_\_ - \_\_\_\_\_

Contractor: \_\_\_\_\_ Phone No: (\_\_\_\_) \_\_\_\_\_ - \_\_\_\_\_

Street or Segment Name: \_\_\_\_\_

Water Main Size: \_\_\_\_\_ Length: \_\_\_\_\_ Material: \_\_\_\_\_ No. of Manholes: \_\_\_\_\_

Start Date: \_\_\_\_\_ / \_\_\_\_\_ / \_\_\_\_\_ Completion Date: \_\_\_\_\_ / \_\_\_\_\_ / \_\_\_\_\_

Street or Segment Name: \_\_\_\_\_

Water Main Size: \_\_\_\_\_ Length: \_\_\_\_\_ Material: \_\_\_\_\_ No. of Manholes: \_\_\_\_\_

Start Date: \_\_\_\_\_ / \_\_\_\_\_ / \_\_\_\_\_ Completion Date: \_\_\_\_\_ / \_\_\_\_\_ / \_\_\_\_\_

Street or Segment Name: \_\_\_\_\_

Water Main Size: \_\_\_\_\_ Length: \_\_\_\_\_ Material: \_\_\_\_\_ No. of Manholes: \_\_\_\_\_

Start Date: \_\_\_\_\_ / \_\_\_\_\_ / \_\_\_\_\_ Completion Date: \_\_\_\_\_ / \_\_\_\_\_ / \_\_\_\_\_



## Cross-Connection Control Program

CHEROKEE COUNTY WATER AND SEWERAGE AUTHORITY

CROSS-CONNECTION CONTROL PROGRAM

ADDENDUM ONE

April 14, 2003

**ALL NEWLY INSTALLED DEVICES SHALL BE TESTED UPON INSTALLATION BY A  
CONTACTOR APPROVED BY THE AUTHORITY.**

# TABLE OF CONTENTS

## **SECTION - I PURPOSE, RESPONSIBILITIES, AND PROCEDURES**

1.1 Purpose	Page 1
1.2 Applicability	Page 1
1.3 Responsibilities	Page 1
1.4 Public Awareness	Page 2
1.5 Resources for Implementation	Page 2
1.6 Emergency Notification	Page 4
1.7 Laboratory	Page 5
1.8 Remedy	Page 5
1.9 Proposed Implementation Schedule	Page 7

## **SECTION - II SELECTION APPROVAL AND INSTALLATION OF DEVICES**

2.1 Selection	Page 8
2.2 Approval of Devices	Page 8
2.3 Installation of Devices	Page 8
2.4 Maintenance and Testing of Devices	Page 9

## **SECTION - III DEFINITIONS**

Definitions	Page 11
-------------	---------

## **APPENDIX**

Policy and Procedures for Cross Connection Control	Appendix - A
High Risk Customer Listing	Appendix - B
Medium Risk Customer Listing	Appendix - C
Typical Installation Drawing RPZ 3/4" to 2-1/2"	Standard 01
Typical Wall Installation Drawing RPZ 3/4" to 2 1/2"	Standard 02
Typical Installation Drawing RPZ 3" to 10"	Standard 03
Typical Installation Drawing RPZ 3" to 10" Non Interrupt Service	Standard 04
Typical Drawing for Filling of Trucks	Standard 05
Typical Drawing Double Check Valve in Vault Size 3" to 12"	Standard 06
Typical Drawing Double Check Valve in Meter Box 1/2" to 2-1/2"	Standard 07
List of Approved Backflow Prevention Devices	Appendix - D
Sample Notification Letters to Customers	Appendix - D
Forms for Site Inspection and BFPD Testing Report	Appendix - D
Warning of Area Contamination	Appendix - D
Expansion Control Notification	Appendix - D

# CROSS-CONNECTION CONTROL PLAN

## SECTION - I PURPOSE, RESPONSIBILITIES, AND PROCEDURES

### 1.1 PURPOSE

To prevent the entry of contaminants or pollutants into any area of the potable water supply through the control of cross-connections. Control shall be accomplished by isolating potential sources of contaminants or pollutants on the customer's premises and or protecting the public supply by isolation and containment at the service connection.

### 1.2 APPLICABILITY

The provisions of backflow prevention by isolation and containment are applicable to any customer or system supplied by the Cherokee County Water and Sewerage Authority's distribution system including irrigation, sprinklers, fire protection systems, residential systems, and other service connections.

### 1.3 RESPONSIBILITIES

1.3.1 The Cherokee County Water and Sewerage Authority and the Cherokee County Commission are responsible for establishing regulations regarding the control of cross-connections to the public distribution system.

1.3.2 *The Water and Sewerage Authority* is responsible for enforcing certain of these regulations in an effort to protect the public water supply system through the prevention of backflow or back siphonage of contaminants or pollutants. This responsibility begins with the production of water and extends throughout the distribution system to the service connection, applying to new construction as well as to existing customers and situations.

1.3.3 *The Cherokee County Department of Public Service* - The Building Inspection Department is responsible for enforcing the Cherokee County adopted plumbing code regulations in an effort to prevent backflows on the customer's premises from entering the customer's own potable water system. As with the Authority this responsibility extends to both new and existing customers.

- 1.3.4 *The Water Customer* is responsible for complying with the Authority regulations including maintenance, testing, and reporting on certain devices. When required customers are required to allow on site inspections to verify compliance with the Authority's cross-connection control policy. The customers also have the dual responsibility for protecting the water in their own system from degradation due to conditions originating on their premises and for protecting the quality of water in the public distribution system. The customer is liable for any health hazard due to backflow from unprotected cross-connections on their premises. When a backflow preventer is required at the service connection, the customer is responsible for the cost of procurement, installation, testing, and maintenance.

#### 1.4 PUBLIC AWARENESS

General methods that the authority may use to inform its customers of the potential dangers from illegal and improper cross-connection include the following.

- 1.4.1 Written description of potential cross-connection location and the need to protect the public water system would be included as special interest articles for newspapers and local publications.
- 1.4.2 Providing speakers for civic clubs, political bodies and other functions.
- 1.4.3 Providing informational pamphlets to be distributed at schools and other locations.
- 1.4.4 Scrolling text messages about backflow prevention will put on the government access channel of the local cable TV.

#### 1.5 RESOURCES FOR IMPLEMENTATION

- 1.5.1 New Construction Plan Review
  - 1.5.1.1 Both the Authority and County Building Department shall review all plans for new construction.
  - 1.5.1.2 Both the Authority and County Building Department shall advise developers of regulations in advance and determine that appropriate protection measures and devices are proposed. Devices required by either the Authority or County Building Department will be installed at the developers, builder, or owner's expense.
  - 1.5.1.4 New construction will be inspected for Cherokee County plumbing code compliance by the Cherokee County Department of Public Services Building Inspection Department to determine that individual

- cross-connections are isolated from the public water supply (isolation policy).
- 1.5.1.5 The Authority will inspect all new service connections for cross-connection control compliance, determine the degree of hazard to the public supply, and assign the customer to a risk category (containment policy). The Authority will refuse service in cases of non-compliance.
- 1.5.2 Existing System and Customers
- 1.5.2.1 The Authority will identify by on site inspection those existing customers or connections to the public supply which represent potential hazards.
  - 1.5.2.2 Customers will be identified and a priority ranking of *high, medium, or low* hazard assigned. Hazard levels will be assigned with respect to the likelihood and consequence of backflow on the site.
  - 1.5.2.3 Letters will be mailed to identified potential cross-connection customers defining cross-connections and indicating that the Authority intends to restrict such connections by requiring the installation of backflow prevention devices. The Authority will provide assistance to the owner by providing a listing of persons or companies approved by the Authority to install and test backflow prevention devices.
  - 1.5.2.4 The Authority will discontinue service in cases of non-compliance.
- 1.5.3 Management and Record Keeping
- 1.5.3.1 The Authority has a designated Cross-Connection Control Program Manager. The program manager will perform site inspections, record keeping, and the sending out of various notifications to customers.
  - 1.5.3.2 The Authority has invested in a personal computer for the purpose of maintaining records, and managing the Cross-Connection Control Program. The computer system includes; a program to track customers, backflow preventer locations, inspections, maintenance and will print letters to customers informing them annual testing is required.
  - 1.5.3.3 The Authority will track the location of high risk customers and the valves necessary to isolate them on a 6' X 6' county road map until a computerized map proposed for the future is available.



1.6 EMERGENCY NOTIFICATION PROCEDURES

Cherokee County Water and Sewerage Authority personnel shall use the following notification procedures in the event of a backflow incident.

- 1.6.1 The following information will be obtained for transmission to the General Manager and the Cross-Connection Control Program Manager by the first employee on the scene.
  - 1.6.1.1 Location, time, and date of incident.
  - 1.6.1.2 Name of person(s) or company and phone number.
  - 1.6.1.3 Type of material involved, if known.
  - 1.6.1.4 Physical description of contamination. Color of water, odor, taste?
  - 1.6.1.5 Is any City, County, or Water Authority personnel on the scene of the incident, (Fire, Police, Pollution Control, etc.)
- 1.6.2 Notification of Water and Sewerage Authority Personnel:
  - 1.6.2.1 Notify General Manager
  - 1.6.2.2 Notify Cross-Connection Control Manager
- 1.6.3 EPD Notification:

Notify the Environmental Protection Division. The Emergency (24 hour) Telephone Numbers are (404) 656-4863 and (404) 656-6905.
- 1.6.4 Cherokee County Department of Public Services Notification:
  - 1.6.4.1 Health Department Personnel:

Health Department Personnel will be notified and requested to respond in the event of an emergency, so that they may assist with the identification and treatment of the contamination.
  - 1.6.4.2 Building Inspectors:

Building Inspectors will be notified and requested to assist in the locating of contamination sources.
- 1.6.5 Water Treatment Plant Personnel Notification:

Water Treatment Plant Personnel shall be notified as to the type of emergency, so that they may assist in the location, identification, and correction of any cross-connection which may affect the supply system. Laboratory personnel from the plant will be required to take samples of the contaminated water for analysis.
- 1.6.6 Public Notification:

If an incident or emergency warrants public notification the following person(s) are authorized to make statements to the news media and shall be in charge of handling the emergency in the order listed:

  - 1.6.6.1 Chairman of the Board of Directors of the Cherokee County Water and Sewerage Authority.
  - 1.6.6.2 General Manager of the Cherokee County Water and Sewerage Authority

1.6.6.3 Public Relations Officer of the Cherokee County Water and Sewerage Authority.

1.6.7 Operation Procedures:

- 1.6.7.1 During normal working hours, all radio transmissions shall cease except for necessary emergency use. Base stations shall be notified by the General Manager or his designated agent(s).
- 1.6.7.2 Service crew or crews shall be dispatched to the scene.
- 1.6.7.3 Service crew(s) shall locate, operate, and turn off customer's water service at the meter and fire line valves.
- 1.6.7.4 Service crews shall be prepared to close all necessary valves to isolate a section of the distribution system when instructed to do so. If the distribution system is contaminated, the contamination shall be contained in the smallest area possible.

1.7 LABORATORY

- 1.7.1 A laboratory technician shall be dispatched to the backflow site.
- 1.7.2 A cross-connection could contaminate only the customer's plumbing system. This is usually the case unless pressure in the water distribution system is less than on the customer's property. The potable water could become discolored and may have an odor present. (Please keep in mind these are the simplest signs to look for, NOT all chemicals are as easy to detect.) Plumbing officials should be notified and approved backflow prevention devices installed before any water fountains are turned back on.
- 1.7.3 The laboratory technician shall collect the necessary samples after the customer's meters and fire service valves have been turned off, and make provisions for further testing if there is a significant change in chlorine residual. Samples will be sent to and to the state lab for identification, and the General Manager notified, so that the area of contaminated water can be valved off and isolated.

1.8 REMEDY

- 1.8.1 After the contaminant is identified, the cross-connection, and the place of occurrence shall be located. All drinking fountains should be turned off. Water service shall be discontinued at the place of occurrence until an approved backflow prevention device is installed and tested.

- 1.8.2 Service crews shall start flushing the water system upon the General Manager's, or his designated agent's order to do so and shall continue flushing lines until lab tests show the contaminant to be at a safe level for human consumption.

1.9 PROPOSED IMPLEMENTATION SCHEDULE

<u>Proposed Date</u>	<u>Item</u>
Feb. 26, 1996	Cherokee County Water and Sewerage Authority Board adopts Cross-Connection Control Policy.
Mar. 12, 1996	Send letters to high risk potential cross-connection customers informing them of the requirements.
Mar. 12, 1996	Begin scheduling and performing high risk customer inspections.
May 12, 1996	Send letters to medium risk potential cross-connection customers.
May 12, 1996	Begin scheduling and performing medium risk customer inspections.
Jun. 12, 1996	Deadline for Improvements for high risk customers.
Nov. 12, 1996	Deadline for Improvements for medium risk customers.
Jan. 1, 1997	Begin charging a \$2.00 fee for record maintenance on high and medium risk customers.
Jan. 1, 1998	Require all residential meter replacements to include a dual check BFPD.
Jan 1, 2000	Require all new construction to have a minimum testable double check valve assembly BFPD.
Jun. 1, 2001	Complete electronic map of water system showing all potential cross-connection locations.

# CROSS-CONNECTION CONTROL PLAN

## SECTION - II SELECTION, APPROVAL, AND INSTALLATION OF DEVICES

### 2.1 SELECTION

Vacuum breakers and backflow preventers shall be selected based on the level of risk that each customer represents. The level of risk (high, medium, or low) will be determined by the degree of hazard and the type cross-connection on each premise. The degree of hazard shall be determined by whether the impurities involved are *contaminants* or *pollutants* and by the type cross-connection whether it is non-pressure or pressure (see Definitions Section). High risk customers shall be required to install an approved reduced pressure zone backflow preventer and have the device tested for proper operation annually. Medium risk customers shall be required to install an approved double check backflow preventer and have the device tested for proper operation annually. Low risk commercial customers shall be required to install an approved double check backflow preventer. Low risk non-commercial customers shall not be required to install backflow prevention devices.

### 2.2 APPROVAL OF DEVICES

All vacuum breakers and backflow preventers shall be approved in accordance with the applicable standards of the American Society of Sanitary Engineering, the American National Standards Institute, the University of Southern California Foundation of Cross Connection Control and Hydraulic Research, and the American Water Works Association.

### 2.3 INSTALLATION OF DEVICES

Vacuum breakers and backflow preventers equipped with atmospheric vents, or with relief openings, shall be so installed and so located as to prevent any vent or any relief opening from being submerged. They shall be installed in the position as recommended by the manufacturer, and shall be protected from freezing.

- 2.3.1 Backflow Preventer, Dual Check Valve (DuCV) Low Risk Category - This device shall not be buried in earth, but may be installed below ground in a meter box. A positive shut-off valve and union shall be near the inlet side of the device. When the device is installed below ground the shut-off valves and unions shall be on both sides.

2.3.2 Backflow Preventer, Double Check Valve (DCV)

*Medium Risk Category* - This device shall not be buried in earth but may be installed below ground in a pit provided ball valve test cocks fitted with brass plugs are used. A positive shut-off valve shall be near the inlet and outlet sides of the device, and three ball valve test cocks provided on the device. A fourth test cock shall be provided on the upstream side of the inlet shut-off valve. When below ground, a union or flange shall be near the inlet and outlet sides. No intervening connections shall be between the shut-off valves and the backflow preventer.

2.3.3 Backflow Preventer Reduced Pressure Zone (RPZ)

*High Risk Category* - This device shall not be installed below ground. Where relief valve discharge could cause water damage, it shall be piped via an air gap, or a funnel, at the vent/relief port to a floor drain or other approved location. A positive shut-off valve shall be near the inlet and outlet sides of the device, and three approved test cocks provided on the device. A fourth test cock shall be provided on the upstream side of the inlet shut-off valve. A bronze strainer with 20-mesh stainless steel screen shall be included between the inlet shut-off valve and the device on sizes through 2-1/2 inch. No intervening branch connection(s) shall be between the shut-offs and the backflow preventer. When the reduced pressure zone device is installed in a line subject to periodic no-flow conditions, and supply pressure subject to fluctuations, an auxiliary directional check with soft disc, capable of functioning in any position the BFP might be installed in, shall be provided between the inlet shut-off valve and the BFP head to lock the supply pressure in, and prevent discharge through the vent/relief port. When a water pressure reducing valve is required in the same line with the RPZ device, it is usually possible to locate the reducing valve upstream of the device and take advantage of the check valve effect of the reducing valve. In such case, the auxiliary directional check would not be required.

2.4 MAINTENANCE AND TESTING OF DEVICES

All backflow preventers shall be maintained in proper working order. High risk customers with RPZ backflow preventers and medium risk customers with DCV backflow preventers shall have the devices tested on an annual basis. The Authority shall keep records of the testing, maintenance, and repair of (High risk) RPZ and (medium risk) DCV backflow preventers, and shall send out notices to customers when annual inspections come due. All backflow preventers shall be

individually factory-tested. Field testing and repairs of these devices shall be by persons approved by the Cherokee County Water and Sewerage Authority.

NOTE: A THERMAL EXPANSION CONTROL DEVICE shall be installed between a backflow preventer and a water heater to limit the static pressure increase due to thermal expansion of the heated water.

# CROSS-CONNECTION CONTROL PLAN

## SECTION - III DEFINITIONS

**Air Gap** - An unobstructed vertical distance between the lowest opening from any pipe or faucet supplying water to a tank, plumbing fixture or other device and the flood level rim of the receptacle.

**Authority** - The Cherokee County Water and Sewerage Authority.

**Backflow Preventer** - A device or means to prevent backflow or back siphonage.

**BFPD** - Backflow Prevention Device.

**Containment** - Installation of an appropriate device at the service connection to prevent backflow or back siphonage.

**Contaminant** - A toxic substance that if introduced into the potable water supply would create a health hazard.

**Cross-Connection Control Program Manager** - Authorized representative of the General Manager of the Cherokee County Water and Sewerage Authority who shall administer the Cross-connection Control Policy.

**Cross-Connection** - A physical connection between two otherwise separate piping systems or vessels one of which contains potable water and the other does not.

**Cross-Connection Non-Pressure Type** - A low inlet installation where a potable water supply pipe is connected or extended below the overflow rim of a receptacle, or an environment, that does not contain potable water and which is at atmospheric pressure.

**Cross-Connection Pressure Type** - An installation where a potable water supply pipe is connected to a closed vessel, or a piping system, that does not contain potable containment water and which is above atmospheric pressure.

**Customer** - Any and all persons, including any individual firm or association, and any municipal or private corporation organized or existing under the laws of this or any other state or county having a service connection to the public water supply.

**Double Check Valve Assembly** - An assembly of at least two independently acting check valves.



**General Manager** - The General Manager of the Cherokee County Water and Sewerage Authority.

**Isolation** - Installation of an appropriate device at the source of a Cross-Connection on a premises to prevent backflow or back siphonage

**Pollutant** - A non-toxic substance that if introduced into the potable water supply would be objectionable but would not create a health hazard.

**Public Water Supply** - The Cherokee County Water and Sewerage Authority water works system furnishing water to Cherokee County, being recognized by the Department of Natural Resources/Environmental Protection Division as the public water supply.

**Reduced Pressure Backflow Prevention Device** - A reduced pressure principal backflow prevention device is a device that consists of two (2) spring-loaded independently acting check valves with an intermediate, or reduced pressure zone draining to the atmosphere by an independently acting relief valve.

**Vacuum Breaker** - A general term applied to a back siphonage prevention device that introduces air into the potable water system.

**Vacuum Breaker Atmospheric Type** - A vacuum breaker designed for use under flow conditions only, not to exceed 24 consecutive hours, and where it will be subject to no static pressure, and no back pressure.

**Vacuum Breaker Hose Type** - A vacuum breaker designed for hose connection only. It is not approved for continuous pressure, static or flowing.

**Vacuum Breaker Pressure Type** - A vacuum breaker designed to operate under continuous pressure; static or flowing, but no back pressure.

# APPENDIX A

CHEROKEE COUNTY WATER AND SEWERAGE AUTHORITY  
POLICY AND PROCEDURES  
for  
CROSS-CONNECTION CONTROL  
January 1996

It is agreed by the Cherokee County Water and Sewerage Authority as follows:

SECTION 1        That the following definitions and terms shall apply in the interpretation and administration of this policy.

The Authority    The Cherokee County Water and Sewerage Authority.

General Manager    The General Manager of the Cherokee County Water and Sewerage Authority.

Cross-Connection Control Program Manager    Authorized representative of the General Manager of the Cherokee County Water and Sewerage Authority who shall administer the Cross-Connection Control Policy.

Public Water Supply    The Cherokee County Water and Sewerage Authority water works system furnishing water to Cherokee County, being recognized by the Department of Natural Resources/Environmental Protection Division as the public water supply.

Cross-Connection    Any physical connection whereby the public water supply is connected with any other water supply system, whether public or private, either inside or outside of any building or buildings, in such a manner that a flow of water into the public water supply is possible either through the manipulation of valves or because of ineffective check or backpressure valves, or because of any other arrangement.

Auxiliary Intake    Any piping connection or other device whereby water may be secured from a source other than the public water supply.

Inter-connection    Any system of piping or arrangement whereby the public water supply is connected directly with a sewer, drain, conduit, pool, storage reservoir, or other device which does or may contain sewage or other waste, or liquid which would be capable of importing contamination to the public water supply.

Person Any and all persons, including any individual firm or association, and any municipal or private corporation organized or existing under the law of this or any other state or country.

- SECTION 2 That the Cherokee County Water and Sewerage Authority is to comply with Chapter 391-3-5.13 of the Georgia Rules for Safe Drinking Water adopted in accordance with this policy, which pertain to cross-connections, and establish an effective, ongoing, backflow prevention program.
- SECTION 3 That no person shall cause a cross-connection, auxiliary intake, by-pass, or interconnection to be made, or allowed to exist.
- SECTION 4 That the General Manager of the Cherokee County Water and Sewerage Authority, as authorized by the Cherokee County Water and Sewerage Authority Board of Directors is primarily responsible for preventing the contamination or pollution of the public water supply by instituting a program of "Backflow Prevention By Containment". Such responsibilities begins at the point of origin of the public water supply and includes all of the distribution system, and terminates at the service connection for the Consumer's water system.
- SECTION 5 That it shall be the duty of the General Manager of the Cherokee County Water and Sewerage Authority to cause inspections to be made of all properties served by the public water supply where cross-connections with the public and re-inspec water supply are deemed possible. The frequency of inspections and re-inspections shall be based on the potential health hazards involved and shall be established by the General Manager of the Cherokee County Water and Sewerage Authority.
- SECTION 6 That the Cross-Connection Control Manager of the Cherokee County Water and Sewerage Authority or authorized representative shall have the right to enter, upon receiving permission, at a reasonable hour, with prior notification, any property serviced by the public water supply for the purpose of inspecting the piping system thereof for cross-connections. Upon request the owner or occupant of any property so serviced shall furnish to the General Manager of the Cherokee County Water and Sewerage Authority or authorized representative any pertinent information, regarding the piping system processes, chemicals used or stored on site, and any biological or radiation hazards. Refusal to allow inspection of piping or to provide requested

pertinent information shall result in the assumption that cross-connections and hazardous substances may exist on the premises.

SECTION 7 That the General Manager of the Cherokee County Water and Sewerage Authority or authorized representative shall require the use of an approved backflow prevention device on the service line serving customers having or assumed to have cross-connections. The required backflow prevention device at the service connection shall provide maximum (Reduced Pressure Zone Assembly - RPZ) or minimum (Double Check Valve Assembly - DCV) protection as concluded by the Cross-Connection Control Manager of the Cherokee County Water and Sewerage Authority.

Backflow prevention devices shall be approved by the Cross-Connection Control Manager of the Cherokee County Water and Sewerage Authority as to manufacturer, model, and size. The method of installation of backflow prevention devices shall be approved by the Cross-Connection Control Manager of the Cherokee County Water and Sewerage Authority prior to installation and shall comply with the criteria set forth by the Cross-Connection Control Manager. All expenses involved in the purchase, installation, maintenance, and testing of the devices shall be borne by the owner or occupant of the property.

All backflow prevention devices shall be maintained in proper working order. Cherokee County Water and Sewerage Authority personnel shall have the right to inspect and test all backflow prevention devices for proper operation whenever deemed necessary by the Cross-Connection Control Manager.

SECTION 8 That the owner or occupant of property served by the public water supply shall on an annual basis have all backflow prevention devices required by the Authority tested for proper operation and a copy of the test results furnish to the Cross-Connection Control Manager of the Cherokee County Water and Sewerage Authority. Annual testing and inspection of backflow prevention devices must be performed by a person pre-approved by the Cross-Connection Control Manager of the Cherokee County Water and Sewerage Authority. All expenses involved in the testing and repair of the devices shall be borne by the owner or occupant of the property. The Cross-Connection Control Manager of the Cherokee County Water and Sewerage Authority shall notify the owner or occupant in writing as to the date of the required testing and a deadline by which testing results must be sent to the Authority.

SECTION 9 That unscheduled testing performed by Cherokee County Water and Sewerage Authority personnel shall not disrupt water service without prior notification to the occupant or owner of the property. Where no duplicate backflow prevention device exists and water service is critical to the continuance of normal operation or protection of life, property, or equipment, the Cherokee County Water and Sewerage Authority shall notify, in writing, the occupant of the premises of plans to discontinue water service to test the backflow prevention device.

SECTION 10 That the owner of occupant of property served by the public water supply where a required backflow prevention device is installed shall pay a monthly fee of \$2.00 to cover the cost of program administration, maintaining records, and mailing notifications.

SECTION 11 That any person who now has a cross-connections in violation of this policy shall be allowed a reasonable time within which to comply with the provisions of this policy. After an investigation of existing conditions and an appraisal of the time required to complete the work involved the Cross-Connection Control Manager of the Cherokee County Water and Sewerage Authority shall set a required completion date for the installation of an appropriate backflow prevention device.

SECTION 12 That whenever any person neglects or refuses to comply with any of the provisions of this policy the General Manager of the Cherokee County Water and Sewerage Authority shall discontinue the public water supply service connection and service shall not be restored until the cross-connection, auxiliary intake, interconnection, or by pass has been discontinued.

Adopted by:

CHEROKEE COUNTY WATER AND SEWERAGE AUTHORITY

By *Hollis A. Latham*

Date *Feb. 26, 1996*

Title Chairman

# APPENDIX B

**CONTACT THE CHEROKEE COUNTY WATER AND SEWERAGE AUTHORITY FOR THE LATEST LIST OF THE HIGH RISK CUSTOMERS.**



# APPENDIX C

**CONTACT THE CHEROKEE COUNTY WATER AND SEWERAGE AUTHORITY FOR THE LATEST LIST OF THE MEDIUM RISK CUSTOMERS.**

# APPENDIX D

Cherokee County Water and Sewerage Authority  
Cross-Connection Control Program  
Phone (770) 479-9107 or (770) 479-1813

**(Today's Date)**

**(Customer Name)**

**(Customer Mailing Address)**

Re: Cross Connection Control  
Preliminary Notice

Dear **(Customer Name)**,

The Cherokee County Water and Sewerage Authority is instituting a new policy and will be making changes to service connections of some water customers in the coming weeks. These changes are being made as a result of Federal and State regulations regarding cross connection and backflow control. The end result of these changes will be a safer water supply system for everyone.

Initial surveys indicate that your service connection is one that will require backflow protection under the new policy. The nature of your business and or service connection makes it possible for contaminated water or chemicals to back flow into the public water supply. Because you may already have devices installed that protect the public water supply or have been mistakenly categorized, it is requested that you allow an inspection of your premise by the Cherokee County Water and Sewerage Authority Cross Connection Control Program Manager to verify you are in the proper category. To schedule an inspection contact Cross Connection Control at (770) 479-9107 or (770) 479-1813. Please respond by scheduling an inspection by **(Today's Date + 30 Days)**.

Should you choose not to allow an inspection of your premise or do not schedule an inspection by **(Today's Date + 30 Days)**, then the Cross Connection Control Program Manager will be forced to place you in a high risk category. High risk categorization will require that you install a reduced pressure zone backflow prevention device. The cost of installing such a device can be several hundred dollars. Failure to install the device will result in termination of service.

Your cooperation is appreciated. Thank You.

Sincerely,

CHEROKEE COUNTY WATER AND SEWERAGE AUTHORITY  
CROSS CONNECTION CONTROL PROGRAM

---

A. Gregory Long, Program Manager

Cherokee County Water and Sewerage Authority  
Cross-Connection Control Program  
Phone (770) 479-9107 or (770) 479-1813

**(Today's Date)**

**(Customer Name)**

**(Customer Mailing Address)**

Re: Cross Connection Control  
Premise Inspection Results

Dear **(Customer Name)**,

The results of our **(Date of Inspection)** inspection of your premise indicates that the backflow prevention devices currently installed are adequate for the risk categorization of your service. You must continue to maintain these devices in working order and have each device test for proper operation (by a person on the Authority's approved list) on an annual basis. A fee of \$2.00 per month will be added to your water bill to cover the cost of maintaining records and sending out testing notifications. You will be notified as to when the next testing of your backflow prevention device is required

Your cooperation is appreciated. Thank You.

Sincerely,

CHEROKEE COUNTY WATER AND SEWERAGE AUTHORITY  
CROSS CONNECTION CONTROL PROGRAM

---

A. Gregory Long, Program Manager

Cherokee County Water and Sewerage Authority  
Cross-Connection Control Program  
Phone (770) 479-9107 or (770) 479-1813

**(Today's Date)**

**(Customer Name)**

**(Customer Mailing Address)**

Re: Cross Connection Control  
Premise Inspection Results

Dear **(Customer Name)**,

The results of our **(Inspection Date)** inspection of your premise indicates that the backflow prevention devices currently installed are inadequate for the risk categorization of your service connection. You must have installed and test for proper operation a **(type of backflow preventer)** backflow prevention device not later than **(Today's Date + 30 Days)**. A partial listing of persons who perform backflow preventer installations and persons qualified to perform annual testing is available from the Authority upon request. For additional information please call the Cross Connection Control Program Manager.

Your cooperation is appreciated. Thank You.

Sincerely,

CHEROKEE COUNTY WATER AND SEWERAGE AUTHORITY  
CROSS CONNECTION CONTROL PROGRAM

---

A. Gregory Long, Program Manager

Cherokee County Water and Sewerage Authority  
Cross-Connection Control Program  
Phone (770) 479-9107 or (770) 479-1813

**(Today's Date)**

**(Customer Name)**

**(Customer Mailing Address)**

Re: Cross Connection Control  
Final Notice

Dear **(Customer Name)**,

Our records indicate that your deadline for compliance with the Cherokee County Water and Sewerage Authority's Cross Connection Control Program expired on **(Expiration Date)**. Please contact the Cross Connection Control Program Manager to set up an installation or inspection date. Failure to contract the Cross Connection Control Program Manager by **(Today's Date + 14 Days)** will result in the termination of your water service. Water service will not be re-established until your service is brought into compliance with the Cross Connection Control Program.

Your cooperation is appreciated. Thank You.

Sincerely,

CHEROKEE COUNTY WATER AND SEWERAGE AUTHORITY  
CROSS CONNECTION CONTROL PROGRAM

---

A. Gregory Long, Program Manager

Cherokee County Water and Sewerage Authority  
Cross-Connection Control Program  
Phone (770) 479-9107 or (770) 479-1813

**(Today's Date)**

**(Customer Name)**

**(Customer Mailing Address)**

Re: Cross Connection Control  
Testing of Backflow Prevention Devices

Dear **(Customer Name)**,

Our records indicate that your backflow prevention device was last tested for proper operation on **(Last inspection Date)**. The Cherokee County Water and Sewerage Authority's Cross Connection Control policy requires that backflow prevention devices be tested on an annual basis by a person approved by the Authority. Accordingly you are required to have your backflow prevention device tested and the attached inspection form filled out and returned to this office no later than **(Today's Date + 30 Days)**. For your information, a list of persons approved to test backflow preventers is attached. If you have any questions please contact the Cross Connection Control Program Manager.

Your cooperation is appreciated. Thank You.

Sincerely,

CHEROKEE COUNTY WATER AND SEWERAGE AUTHORITY  
CROSS CONNECTION CONTROL PROGRAM

---

A. Gregory Long, Program Manager



# Cherokee County Water and Sewerage Authority Backflow Prevention Site Inspection Report

Inspection Date \_\_\_\_\_

Customer Number \_\_\_\_\_

Map Grid Coordinates \_\_\_\_\_

Meter Book ID \_\_\_\_\_

Name of Business \_\_\_\_\_

Type of Business \_\_\_\_\_

**STREET ADDRESS**

**BILLING ADDRESS**

\_\_\_\_\_  
Individual or Business Name

\_\_\_\_\_  
Individual or Business Mailing Address if Different

\_\_\_\_\_  
Street Address

\_\_\_\_\_  
Street or Post Office Box

\_\_\_\_\_  
City State Zip

\_\_\_\_\_  
City State Zip

Contact Person \_\_\_\_\_

Phone Number (      ) \_\_\_\_\_

Type of Business \_\_\_\_\_

Permitting Authority \_\_\_\_\_

Risk Classification      HIGH      MED      LOW

BFP Last Tested \_\_\_\_\_

Current Type of BFP      RPZ      DC      NONE

BFP Test Company \_\_\_\_\_

Required Type of BFP      RPZ      DC      NONE

BFP Tester \_\_\_\_\_

BFP Information      \_\_\_\_\_  
Size      Make      Model

BFP Location \_\_\_\_\_

Site Inspection By: \_\_\_\_\_

Signature

Date

Notes:

---

---

---

---

---

---

---

---

---

---

## Backflow Prevention Device Inspection Report

### Cherokee County Water and Sewerage Authority

Name of Owner _____			
Mailing Address _____			
Name of Premises _____			
Street Address _____			
Location of Assembly _____			Install. Date _____
Type of Assembly _____	Manufacturer _____		Size _____
Model Number _____	Serial Number _____		
Tested by (Firm Name) _____			Tester's Name _____
Business Address _____			Telephone _____
Date of Test _____	Fault _____		
Reason for Failure (if apparent) _____			Date of Retest _____
Maintenance _____			
I certify that I have tested the above assembly and that it meets the performance requirements of the Cherokee County WSA Cross Connection Control Program. Signature: _____			
Line Pressure at Time of Test _____ psi		Drop Across Check Valve 1 _____ psid	
	<b>Check Valve 1</b>	<b>Check Valve 2</b>	<b>Differential Pressure Relief Valve</b>
Initial	1. Leaked _____ RP _____ psid	1. Leaked _____	1. Opened at _____ psid reduced pressure.
Test	2. Closed Tight _____	2. Closed Tight _____	2. Did Not Open _____
R E P A I R S	Cleaned _____	Cleaned _____	Cleaned _____
	Replaced _____	Replaced _____	Replaced _____
	Disc _____	Disc _____	Disc, Upper _____
	Spring _____	Spring _____	Disc, Lower _____
	Guide _____	Guide _____	Spring _____
	Pin Retainer _____	Pin Retainer _____	Diaphragm, Large _____
	Hinge Pin _____	Hinge Pin _____	Upper _____
Seat _____	Seat _____	Lower _____	
Diaphragm _____	Diaphragm _____	Diaphragm, Small _____	
Other, Describe _____	Other, Describe _____	Upper _____	
			Lower _____
			Spacer, Lower _____
			Other _____
Final	RP _____ psid		Opened at _____ psid
Test	Closed Tight _____	Closed Tight _____	reduced pressure.

Remarks: \_\_\_\_\_

\_\_\_\_\_

\_\_\_\_\_

\_\_\_\_\_

\_\_\_\_\_



# WARNING

\*\*\*\*\*

The water distribution system in your area may be contaminated. As a precaution the Cherokee County Water and Sewerage Authority has turned off your water service at the meter. Do not use any water that may still be in your lines.

Service Crews from the Authority will work continuously until the source of contamination is found and eliminated.

Your water service will be restored after the contamination is eliminated and the water in the distribution system is tested to make sure it is safe.

Because some contamination may remain in your service line it is requested that you thoroughly flush the lines in your home or business once water service is restored.

To flush your lines simply turn on the water at sinks, tubs, and other locations and allow it to run for at least five minutes. Flush hot water lines by the same method.

Remember to flush the automatic ice maker in your refrigerator, by emptying the ice bin and allowing it to fill completely several times. Other appliances that have direct connection to your water service may also require flushing.

If you have any questions please call (770) 479-9107 or (770) 479-1813  
Your cooperation during this emergency is appreciated.

\*\*\*\*\*

# NOTICE

\*\*\*\*\*

When a backflow prevention device is installed on a water service that has a water heater, a thermal expansion control device should be installed to limit the increase in static pressure due to the thermal expansion of the heated water.

Installation of a thermal expansion control device is not required by the Cherokee County Water and Sewerage Authority but is recommended. A variety of devices are produced to control thermal expansion, your local plumber can install one for you.

If you have any questions or would like a list of devices you can install yourself please call (770) 479-9107 or (770) 479-1813

\*\*\*\*\*



2010  
WATER  
DETAILS

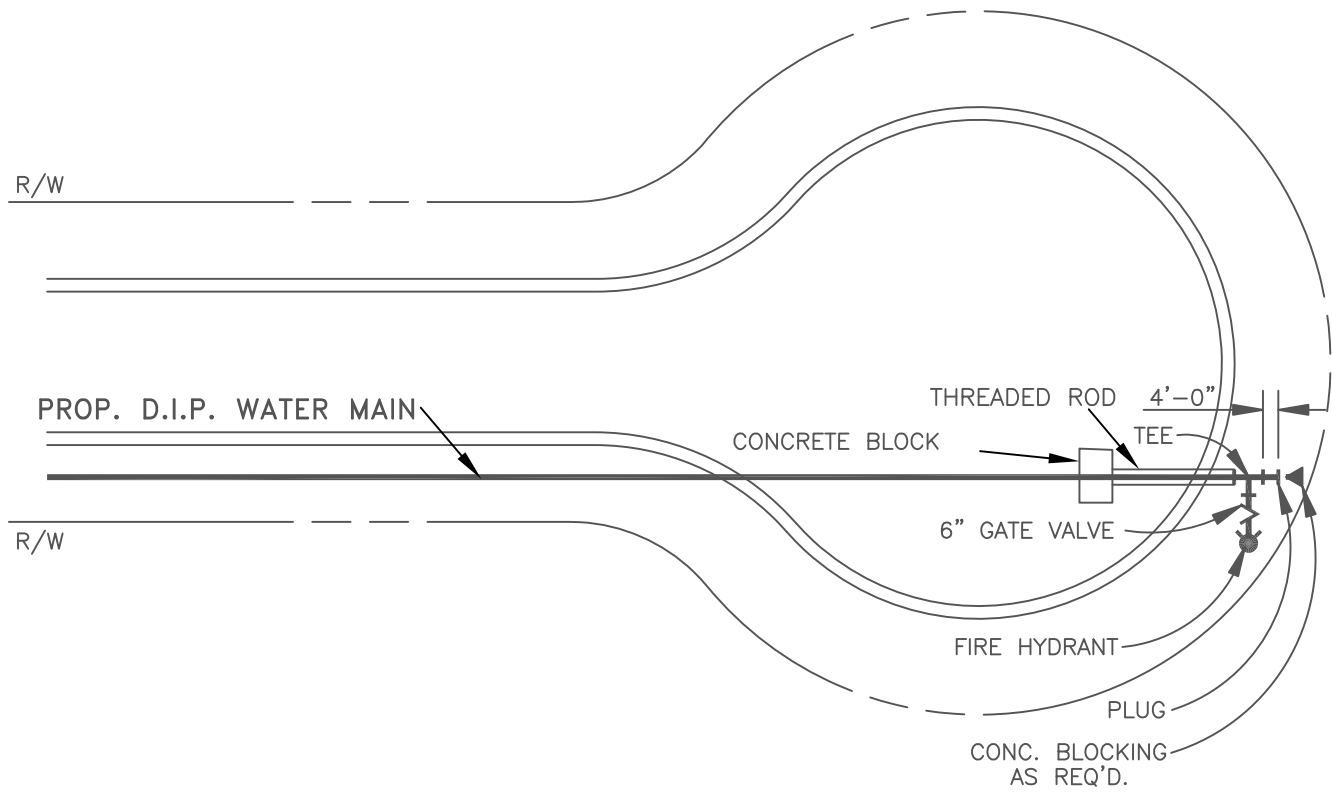

TYPICAL WATER MAIN  
AT CUL-DE-SAC

<b>CHEROKEE COUNTY WATER &amp; SEWERAGE AUTHORITY</b>	<b>TYPICAL WATER MAIN AT CUL-DE-SAC</b> CONSTRUCTION STANDARD	DATE:	FEB. '03	STANDARD NO.  <b>W701</b>
		APPROVED:		

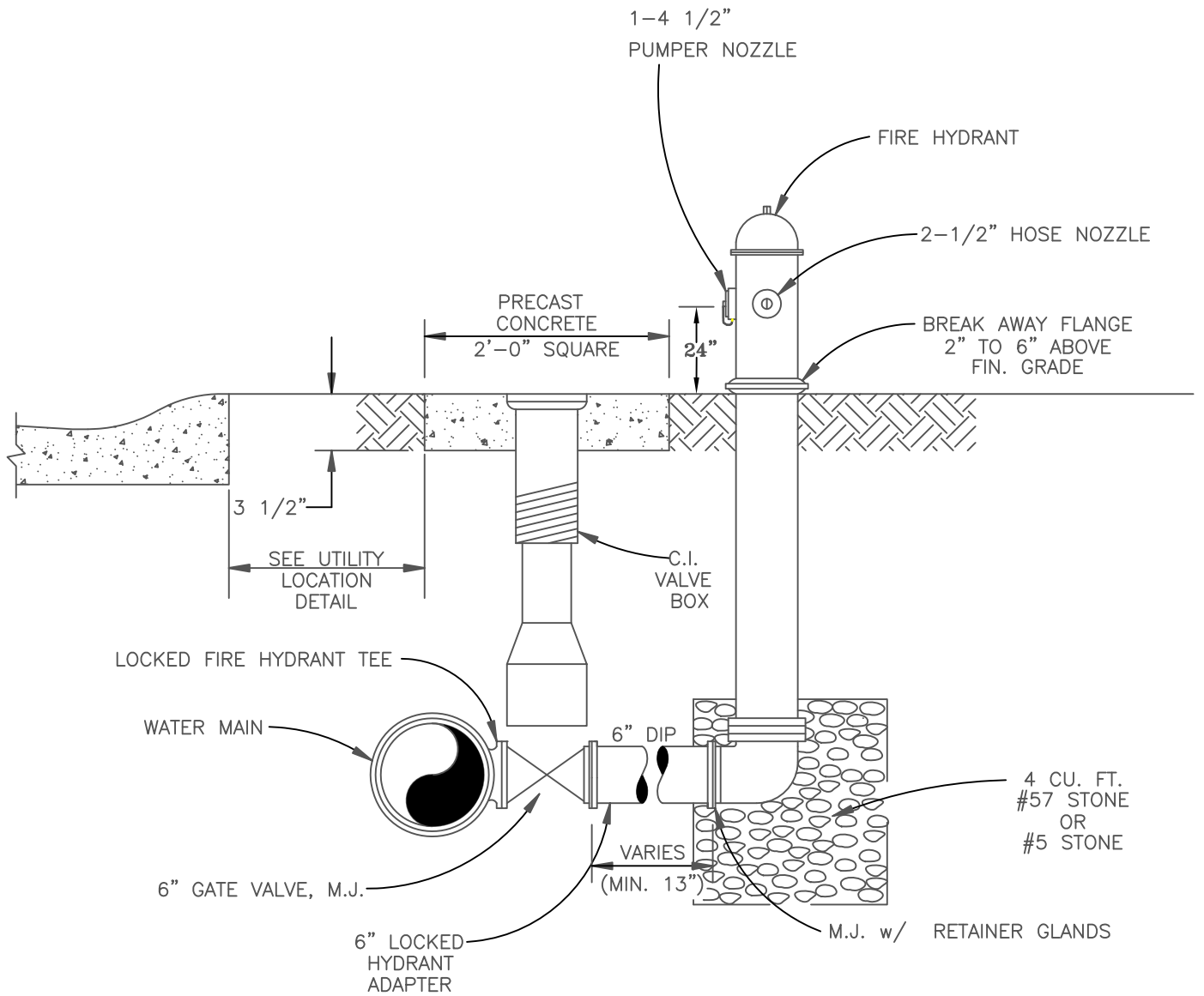

**NOTES:**

1. 4 1/2" PUMPER NOZZLE TO FACE STREET
2. HYDRANT NOT TO BE SET ON STREET SIDE OF WATER MAIN
3. VALVE BOX TO BE ADJUSTED TO GRADE
4. CONCRETE COLLAR AROUND VALVE BOX IF NOT IN PAVED AREA
5. GRAVEL TO BE PLACED AROUND HYDRANT DRAIN, MINIMUM DIMENSIONS 20" x 20" x 20"

**TYPICAL FIRE HYDRANT INSTALLATION**

<b>CHEROKEE COUNTY WATER &amp; SEWERAGE AUTHORITY</b>	<b>TYPICAL FIRE HYDRANT INSTALLATION</b> CONSTRUCTION STANDARD	DATE: FEB. '03	STANDARD NO. <b>W702</b>
		APPROVED:	

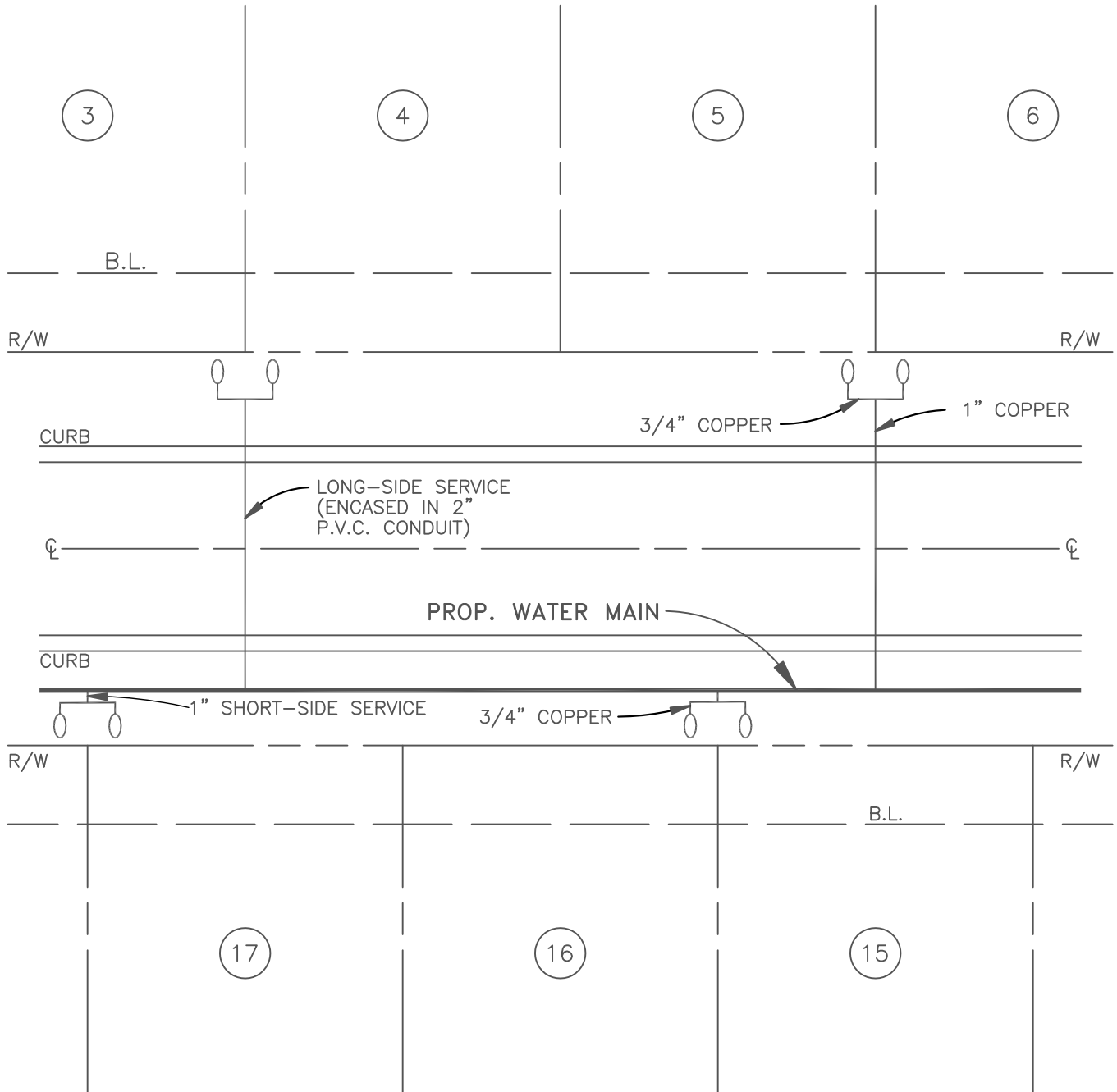

**3/4" WATER METER LOCATION**  
**(FOR SUBDIVISION)**

**NOTE: WATER METER BOXES MUST BE  
 AT LEAST 6' APART**

<b>CHEROKEE COUNTY          WATER &amp; SEWERAGE          AUTHORITY</b>	<b>3/4" WATER          METER LOCATION          (FOR SUBDIVISIONS)</b> CONSTRUCTION STANDARD	DATE: FEB. '03	STANDARD NO. <b>W703</b>
		APPROVED:	



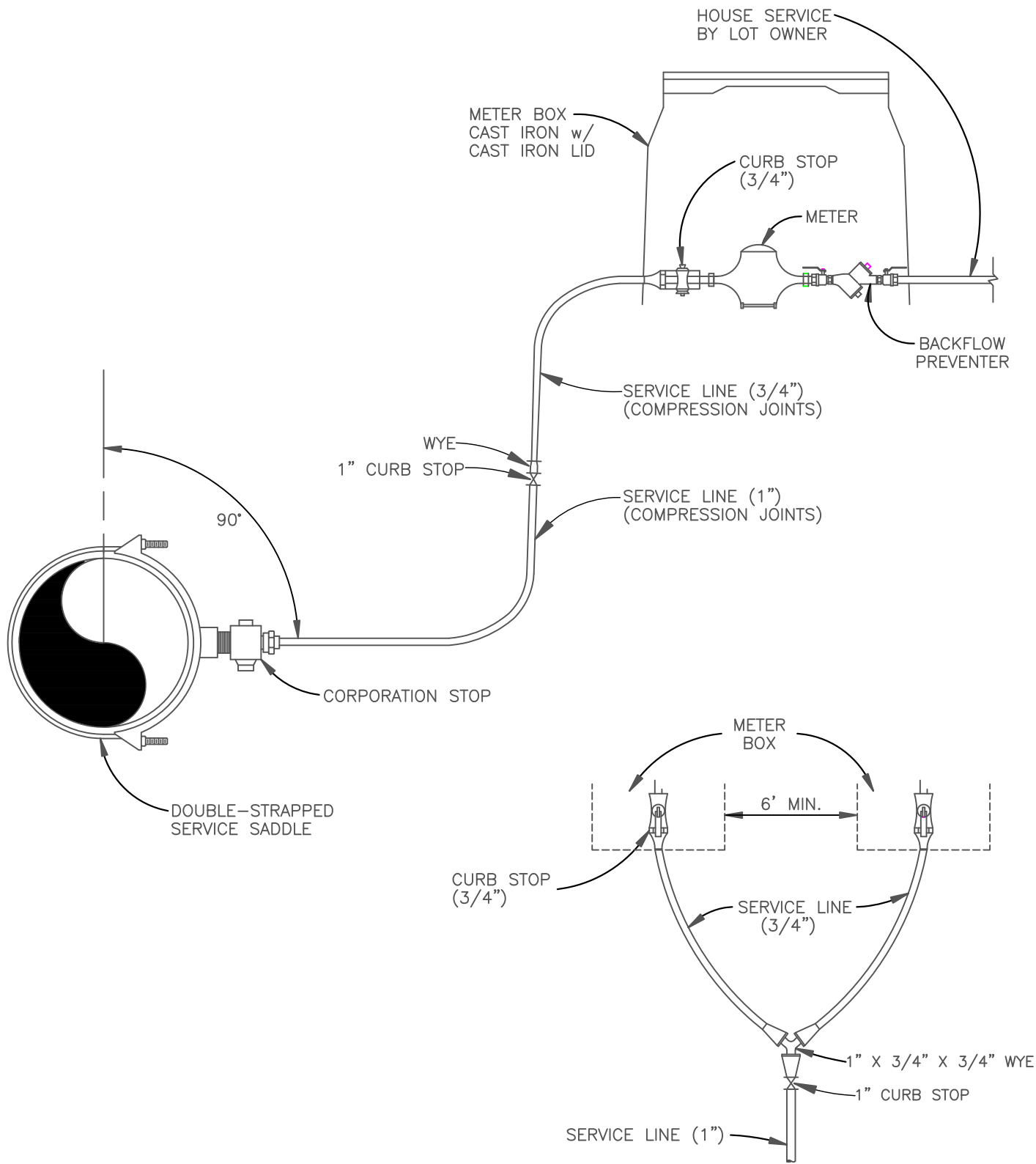

**PLAN FOR WYE**

**CHEROKEE COUNTY  
WATER & SEWERAGE  
AUTHORITY**

**RESIDENTIAL  
WATER METER  
INSTALLATION  
CONSTRUCTION STANDARD**

DATE: FEB. '03

APPROVED:

STANDARD  
NO.  
**W704**

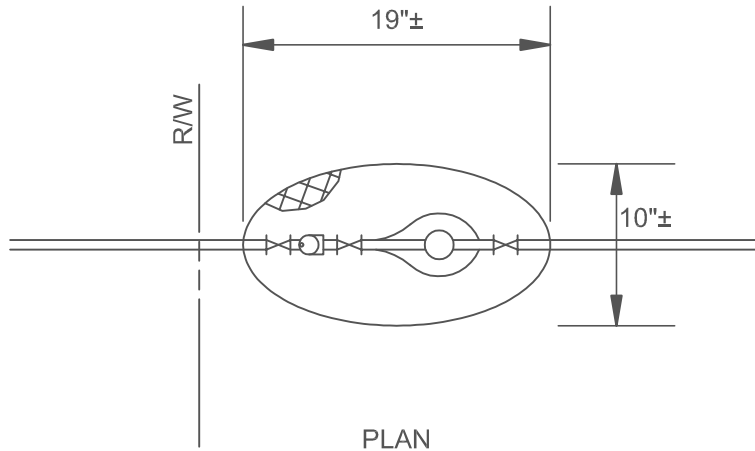

PLAN

- Note:
- 1.) If Meter Box/Cleanout is located in driveway or sidewalk. Meter Box and lid shall be traffic rated.
  - 2.) Easement is required for Meter Box/Cleanout located outside of Right of Way.
  - 3.) Meter Box shall be supported with compacted soil, gravel, etc. to keep top of box from settling below finished grade. Bricks can be used but shall not be placed on top of water lines.

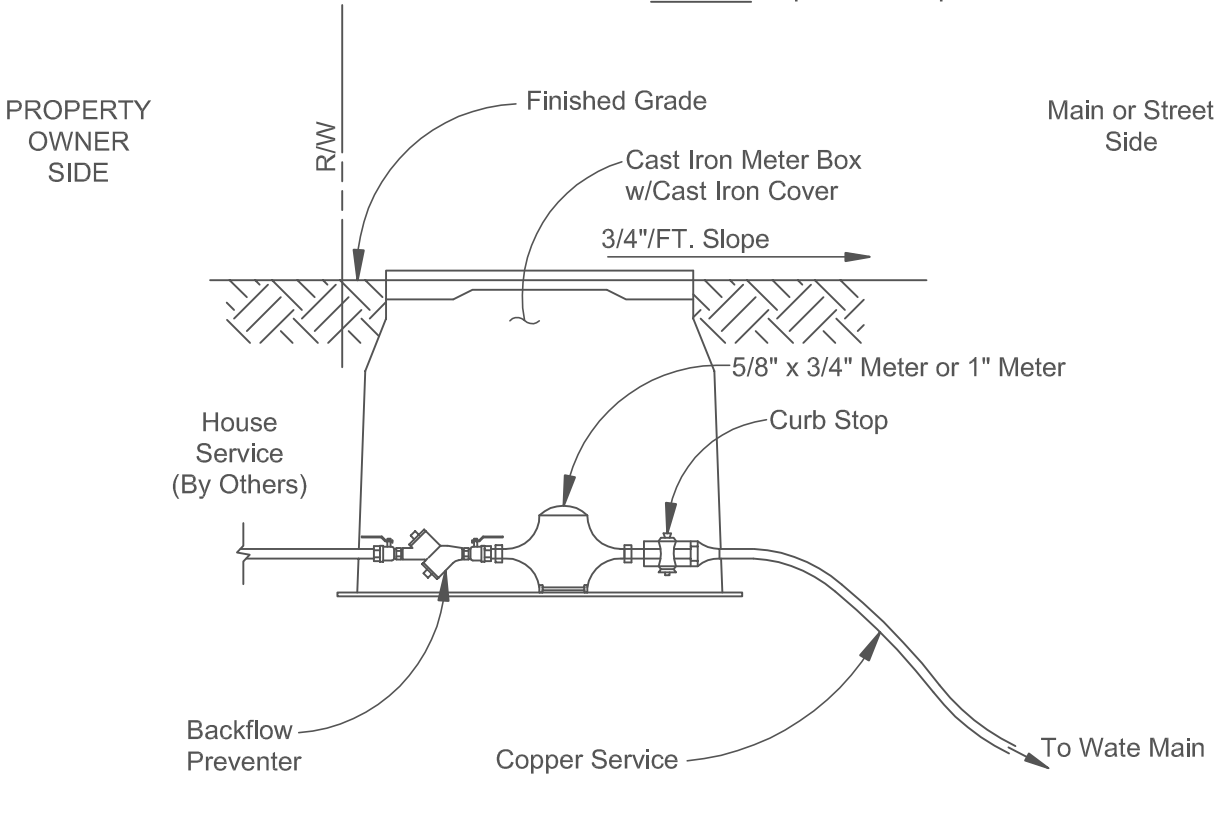

SECTION

CHEROKEE COUNTY  
WATER & SEWERAGE  
AUTHORITY

METER BOX FOR  
5/8" OR 1"  
METER  
CONSTRUCTION STANDARD

DATE:	FEB. '03
Revised:	June '13
APPROVED:	

STANDARD  
NO.  
**W705**

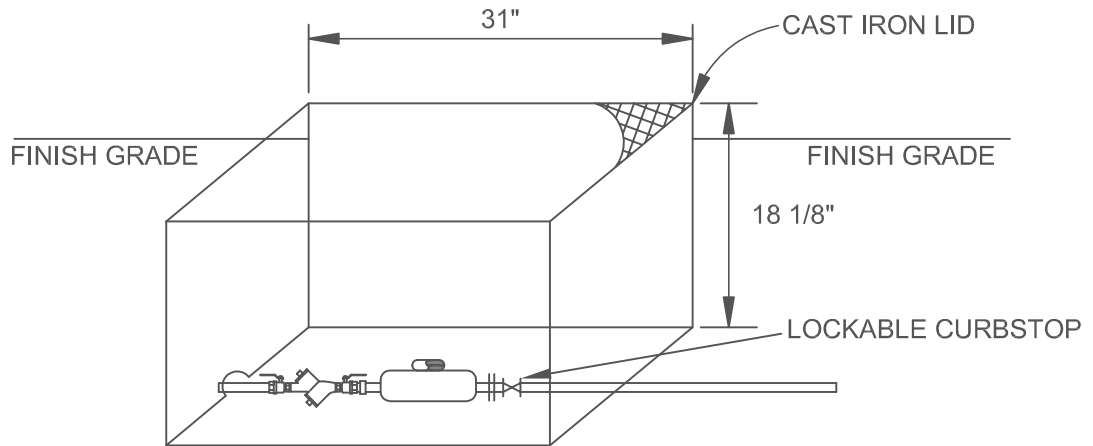

Note:

- 1.) If Meter Box is located in driveway or sidewalk.  
Meter Box and lid shall be traffic rated.
- 2.) Easement is required for Meter Box located outside of Right of Way.
- 3.) Meter Box shall be supported with compacted soil, gravel, etc. to keep top of box from settling below finished grade. Bricks can be used but shall not be placed on top of water lines.
- 4.) Jumbo boxes are to be used with meters larger than 1" and smaller than 3". (1.5" and 2" meter)
- 5.) A two bolt flange is required for the connection of these size meters.
- 6.) All meters larger than 3/4" must have a lockable curbstop.
- 7.) Meter Box: Sigma (MBX-5A) or equal acceptable by the Authority.

CHEROKEE COUNTY  
WATER & SEWERAGE  
AUTHORITY

STANDARD  
JUMBO CAST IRON  
METER BOX  
CONSTRUCTION STANDARD

DATE:	FEB. '03
REV.	JAN. '10
REV.	June '13

APPROVED:

STANDARD  
NO.  
**W706**

Note:

- 1.) If Meter Box/Cleanout is located in driveway or sidewalk.  
Meter Box and lid shall be traffic rated.
- 2.) Easement is required for Meter Box/Cleanout located outside of Right of Way.
- 3.) Meter Box shall be supported with compacted soil, gravel, etc. to keep top of box from settling below finished grade. Bricks can be used but shall not be placed on top of water lines.

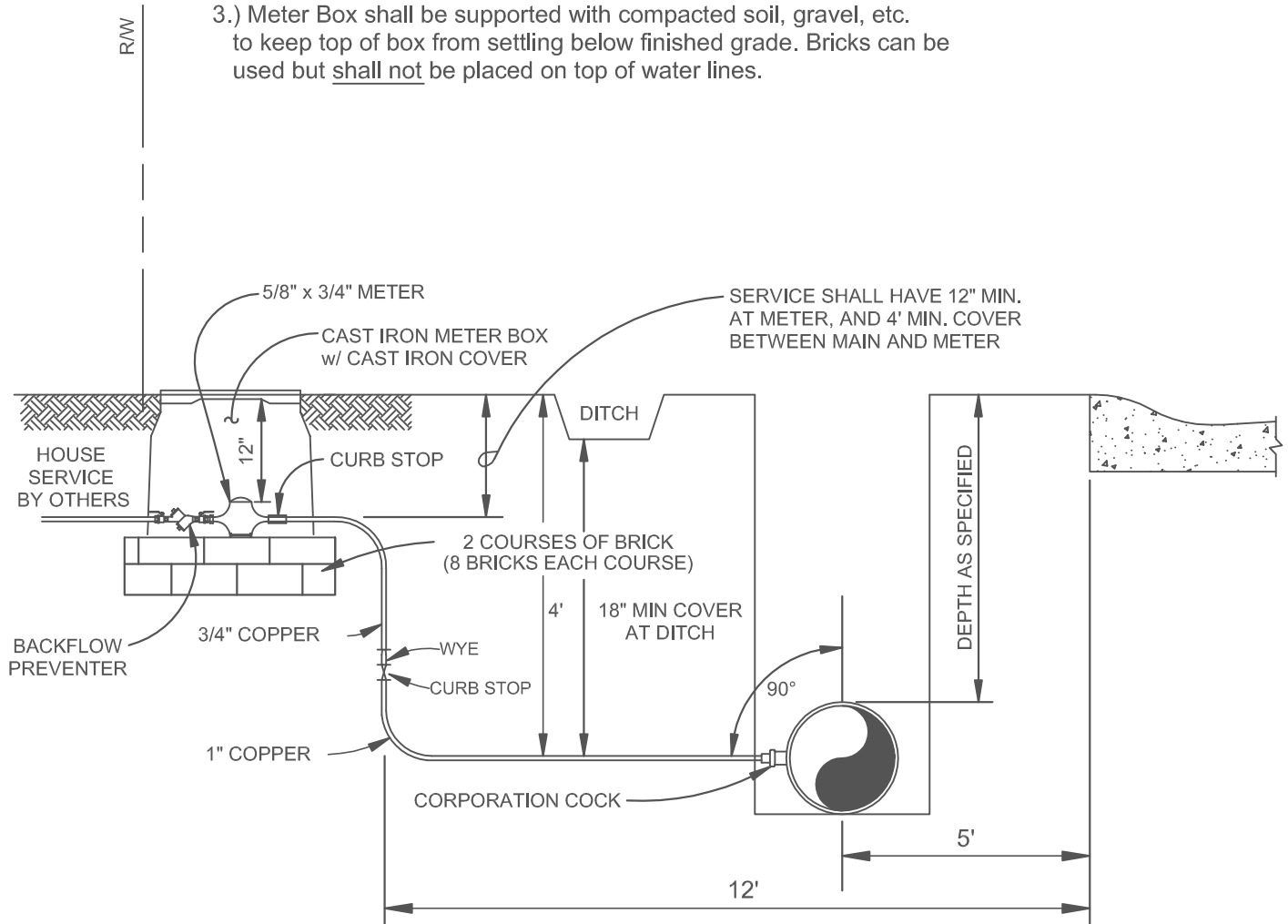

**NOTES:**

1. SERVICE LINE SHALL BE 3/4" FROM MAIN WHEN ONLY ONE 3/4" SERVICE IS REQUIRED.
2. USE ALL COMPRESSION JOINTS.
3. INSTALLATION SHALL ALLOW ADEQUATE ROOM TO REMOVE AND/OR REPAIR METER.

**HOUSE SERVICE INSTALLATION**

<p><b>CHEROKEE COUNTY WATER &amp; SEWERAGE AUTHORITY</b></p>	<p><b>HOUSE SERVICE INSTALLATION</b></p> <p>CONSTRUCTION STANDARD</p>	DATE: FEB. '03	<p>STANDARD NO. <b>W707</b></p>
		Revised: June '13	
		APPROVED:	

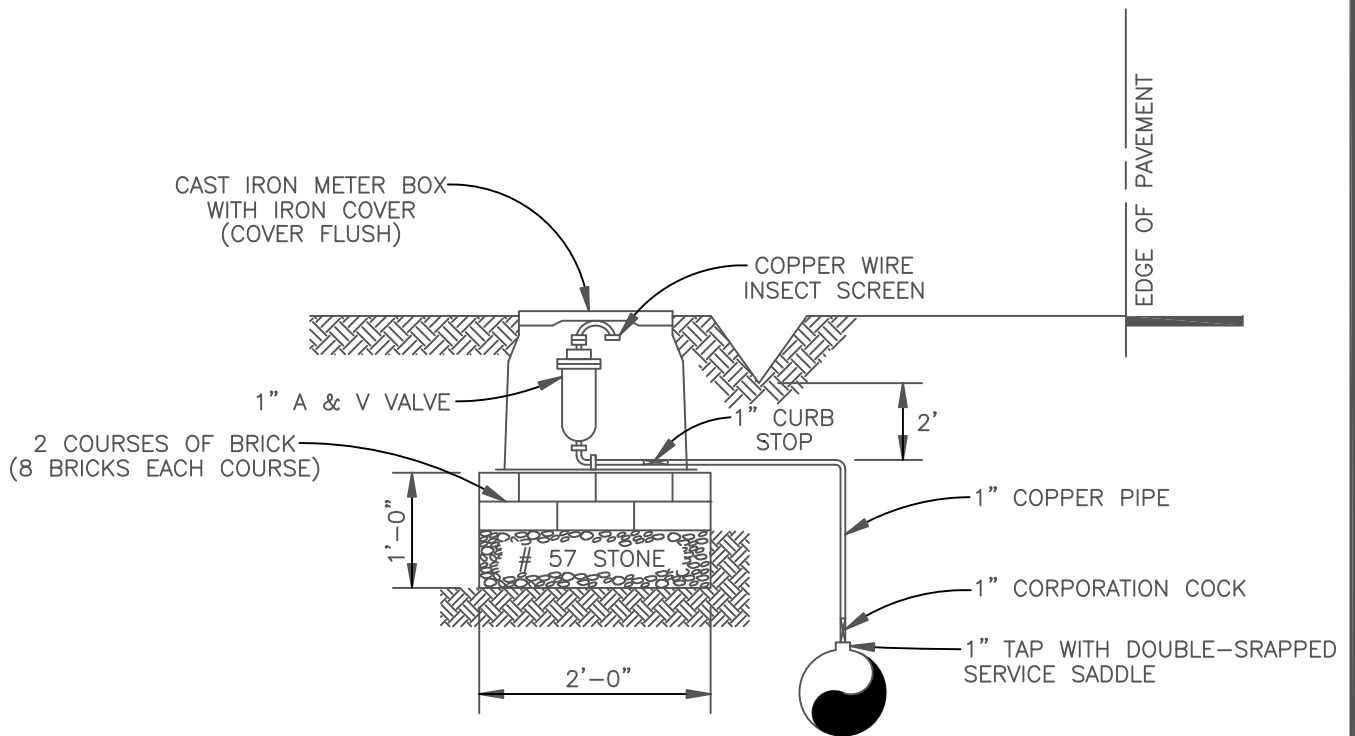

NOTES: 1. VALVE MARKER REQUIRED.

TYPICAL WATER AIR & VACUUM RELEASE VALVE ASSEMBLY

<b>CHEROKEE COUNTY WATER &amp; SEWERAGE AUTHORITY</b>	<b>WATER A&amp;V RELEASE VALVE ASSEMBLY</b> CONSTRUCTION STANDARD	DATE: FEB. '03	STANDARD NO. <b>W708</b>
		APPROVED:	

# TYPICAL ROAD CROSSING WATER MAIN

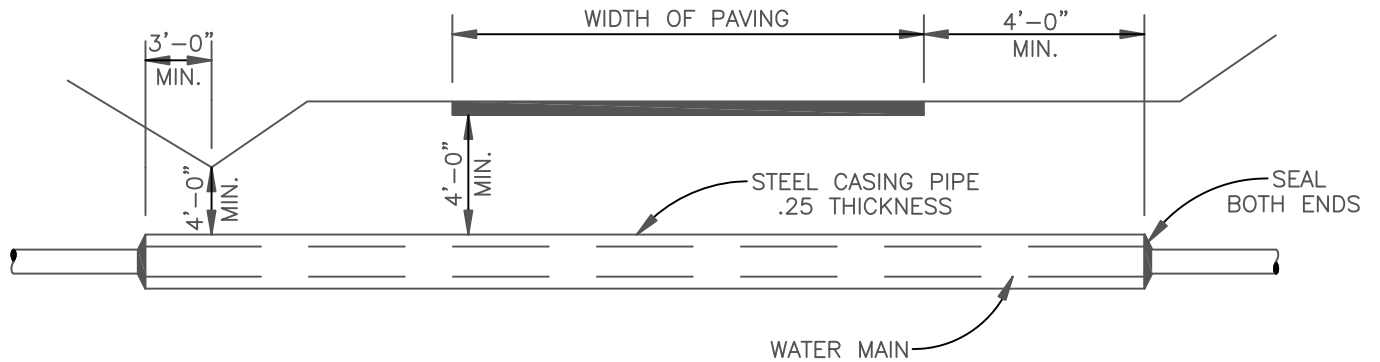

NOTES:

1. CASING PIPE SHALL EXTEND A MINIMUM OF 3' BEYOND TOE OF FILL SLOPES OR DITCH LINES AND 4' BEYOND EDGE OF PVMT. AND BACK OF CURB.

**CHEROKEE COUNTY  
WATER & SEWERAGE  
AUTHORITY**

**TYPICAL ROAD  
CROSSING  
WATER MAIN**  
CONSTRUCTION STANDARD

DATE: MAR. '04

APPROVED:

STANDARD  
NO.  
**W709**

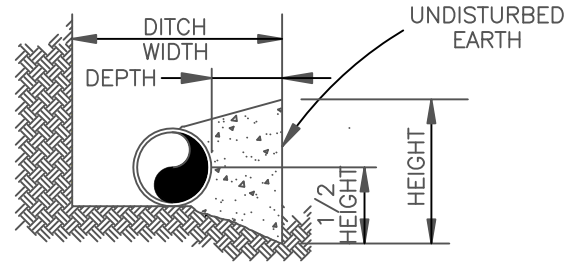
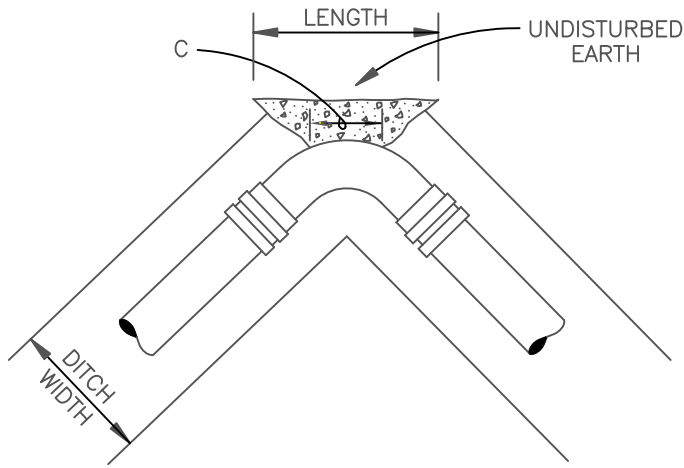

TABLE FOR CONCRETE BLOCKING  
(250 PSI TEST PRESSURE)

MINIMUM DIMENSIONS OF BLOCKING								
FITTING	SIZE	DEPTH (FT.)	LENGTH (FT.)	"C" (IN.)	HEIGHT (FT.)	VOLUME (C.Y.)	THRUST (LB.)	
11 1/4° BEND	6"	1.0	2.0	6	1.0	0.04	1,385	
11 1/4° BEND	8"	1.0	2.0	7	1.0	0.05	2,465	
11 1/4° BEND	10"	1.0	2.0	9	1.0	0.07	3,850	
11 1/4° BEND	12"	1.0	2.5	11	1.5	0.12	5,550	
11 1/4° BEND	16"	2.0	2.5	12	2.1	0.26	9,860	
11 1/4° BEND	20"	2.0	3.5	15	2.5	0.48	15,406	
11 1/4° BEND	24"	2.0	4.0	18	3.0	0.70	22,185	
22 1/2° BEND	6"	1.0	2.0	6	1.0	0.04	2,760	
22 1/2° BEND	8"	1.0	2.0	7	1.5	0.06	4,905	
22 1/2° BEND	10"	1.0	2.0	9	2.0	0.10	7,665	
22 1/2° BEND	12"	1.0	3.0	11	2.0	0.16	11,040	
22 1/2° BEND	16"	2.0	3.5	12	3.0	0.45	19,625	
22 1/2° BEND	20"	2.0	4.0	15	4.0	0.74	30,665	
22 1/2° BEND	24"	3.0	5.0	18	4.5	1.47	44,160	
45° BEND	6"	1.0	2.0	6	1.5	0.06	5,415	
45° BEND	8"	1.0	2.5	7	2.0	0.10	9,625	
45° BEND	10"	2.0	3.5	9	2.5	0.31	15,040	
45° BEND	12"	2.0	3.5	11	3.0	0.41	21,655	
45° BEND	16"	3.0	5.0	12	4.0	1.45	38,495	
45° BEND	20"	4.0	6.0	15	5.0	2.05	60,145	
45° BEND	24"	4.0	7.5	18	6.5	3.35	91,610	
90° BEND	6"	1.0	2.5	12	2.0	0.13	10,005	
90° BEND	8"	2.0	3.0	14	3.0	0.38	17,785	
90° BEND	10"	2.5	4.5	18	3.0	0.74	27,785	
90° BEND	12"	3.0	5.0	20	4.0	1.24	40,000	
90° BEND	16"	4.0	6.5	26	5.5	2.91	71,125	
90° BEND	20"	4.0	8.0	32	7.0	4.68	111,135	
90° BEND	24"	5.0	10.0	40	8.0	8.50	160,035	

NOTES:

1. SOIL BEARING STRENGTH OF 2000 PSI IS ASSUMED IN THE CALCULATIONS ABOVE. ENGINEER SHALL VERIFY.
2. COVER GLANDS AND BOLTS WITH POLYETHYLENE BEFORE PLACING CONCRETE.
3. ALLOW CONCRETE TO SET UP A MINIMUM OF 6 HOURS BEFORE PLACING BACKFILL.
4. CONCRETE SHALL BE 3000 PSI, CLASS A.
5. ALL IRON FITTINGS SHALL BE BLOCKED AND SUPPORTED AS SHOWN ABOVE.
6. VERTICAL BENDS WITH AN UPWARD THRUST SHALL BE RESTRAINED AS SHOWN IN STANDARD W715.
7. VERTICAL BENDS WITH A DOWNWARD THRUST SHALL BE RESTRAINED AS SHOWN IN STANDARD W716.

CONCRETE BLOCKING FOR BENDS

<b>CHEROKEE COUNTY WATER &amp; SEWERAGE AUTHORITY</b>	<b>CONCRETE BLOCKING DETAIL</b>  CONSTRUCTION STANDARD	DATE: FEB. '03	STANDARD NO.  <b>W710</b>
		APPROVED:	

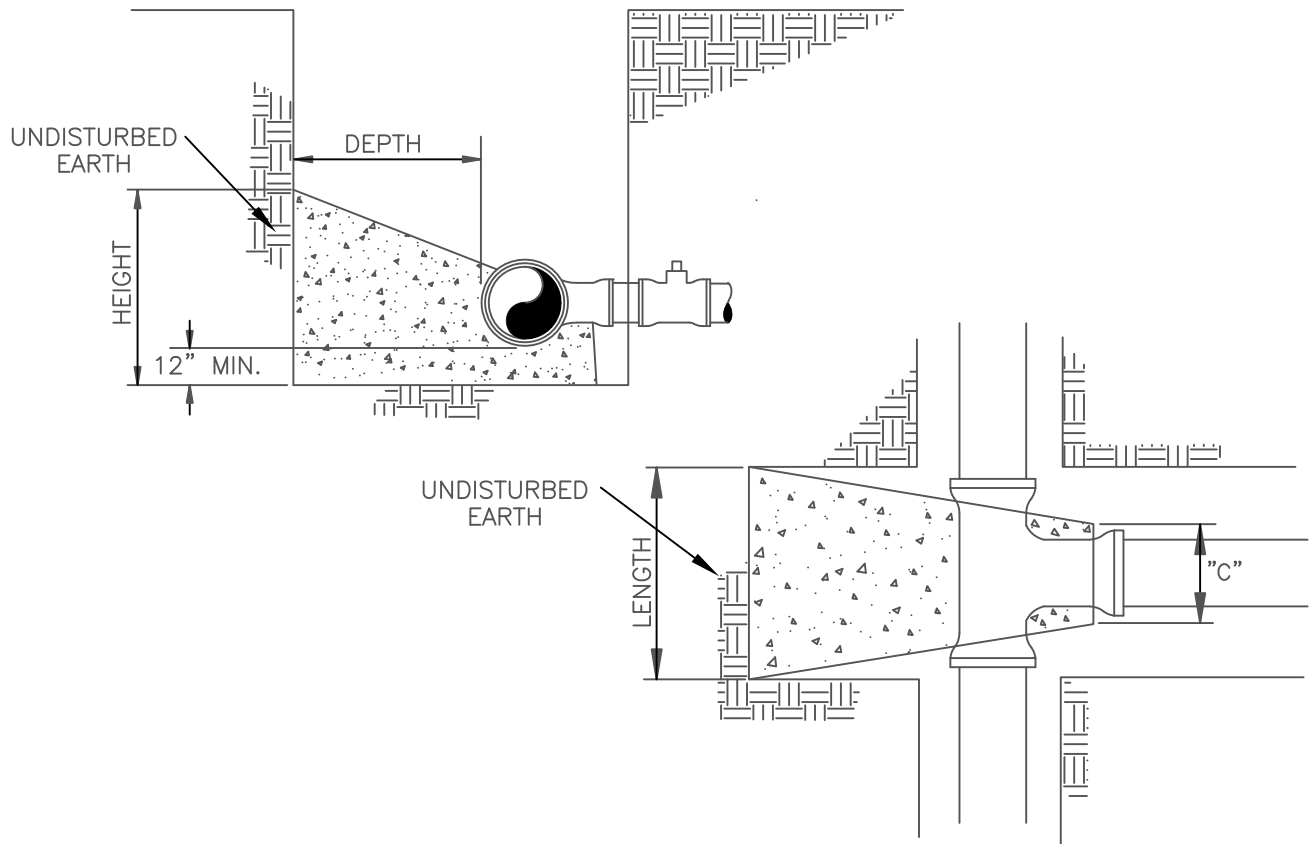

TABLE FOR CONCRETE BLOCKING  
(250 PSI TEST PRESSURE)

SIZE	DEPTH (FT.)	LENGTH (FT.)	"C" (IN.)	HEIGHT (FT.)	VOLUME (C.Y.)	THRUST (LB.)
6"	1.0	2.5	12	1.5	0.10	7,070
8"	1.7	3.25	14	2.0	0.27	12,565
10"	2.0	4.0	18	2.5	0.50	19,635
12"	2.5	4.5	20	3.25	0.91	28,275
16"	3.0	5.0	26	5.0	1.77	50,265
20"	4.0	7.0	32	5.75	3.69	78,540
24"	6.0	9.0	40	6.5	7.94	113,100

**NOTES:**

1. SOIL BEARING STRENGTH OF 2000 PSI IS ASSUMED IN THE CALCULATIONS ABOVE. ENGINEER SHALL VERIFY.
2. COVER GLANDS AND BOLTS WITH POLYETHYLENE BEFORE PLACING CONCRETE.
3. ALLOW CONCRETE TO SET UP A MINIMUM OF 6 HOURS BEFORE PLACING BACKFILL.
4. CONCRETE SHALL BE 3000 PSI, CLASS A.
5. ALL IRON FITTINGS SHALL BE BLOCKED AND SUPPORTED AS SHOWN ABOVE.

**CONCRETE BLOCKING FOR TEES AND PLUGS**

<b>CHEROKEE COUNTY WATER &amp; SEWERAGE AUTHORITY</b>	<b>CONCRETE BLOCKING DETAIL</b>  CONSTRUCTION STANDARD	DATE: FEB. '03	STANDARD NO.  W711
		APPROVED:	



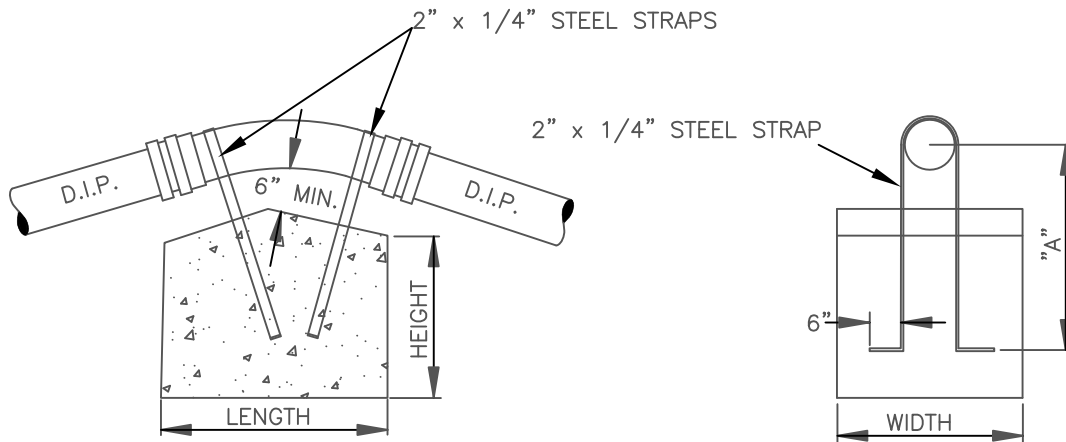

TABLE FOR CONCRETE BLOCKING  
(250 PSI TEST PRESSURE)

FITTING	SIZE	MINIMUM DIMENSIONS OF BLOCKING				VOLUME (C.Y.)	"A" (IN.)	LENGTH OF STRAP (IN.)
		HEIGHT (FT.)	LENGTH (FT.)	WIDTH (FT.)				
11 1/4" BEND	6"	2.0	2.0	2.5	0.37	24	69.5	
11 1/4" BEND	8"	3.0	2.2	2.5	0.61	24	72.5	
11 1/4" BEND	10"	3.0	3.0	3.0	1.00	26	80.0	
11 1/4" BEND	12"	3.0	4.0	3.0	1.33	30	91.0	
11 1/4" BEND	16"	3.0	5.0	4.5	2.50	30	97.0	
11 1/4" BEND	20"	3.3	6.0	5.0	3.67	36	115.0	
11 1/4" BEND	24"	4.0	6.5	5.5	5.30	36	122.0	
22 1/2" BEND	6"	2.5	3.0	2.5	0.69	24	69.5	
22 1/2" BEND	8"	3.1	3.5	3.0	1.21	24	72.5	
22 1/2" BEND	10"	3.2	4.0	4.0	1.90	26	80.0	
22 1/2" BEND	12"	3.5	5.0	4.5	2.92	30	91.0	
22 1/2" BEND	16"	4.7	5.5	5.0	4.79	36	109.0	
22 1/2" BEND	20"	6.0	6.0	5.7	7.60	45	133.0	
22 1/2" BEND	24"	8.0	5.7	6.5	10.98	60	170.0	

NOTES:

1. COVER GLANDS AND BOLTS WITH POLYETHYLENE BEFORE PLACING CONCRETE.
2. ALLOW CONCRETE TO SET UP A MINIMUM OF 6 HOURS BEFORE PLACING BACKFILL.
3. CONCRETE SHALL BE 3000 PSI, CLASS A.
4. ALL IRON FITTINGS SHALL BE BLOCKED AND SUPPORTED AS SHOWN ABOVE.

CONCRETE BLOCKING—VERTICAL BENDS—UPWARD THRUST

<b>CHEROKEE COUNTY WATER &amp; SEWERAGE AUTHORITY</b>	<b>CONCRETE BLOCKING DETAIL</b>  CONSTRUCTION STANDARD	DATE: FEB. '03	STANDARD NO.  W712
		APPROVED:	

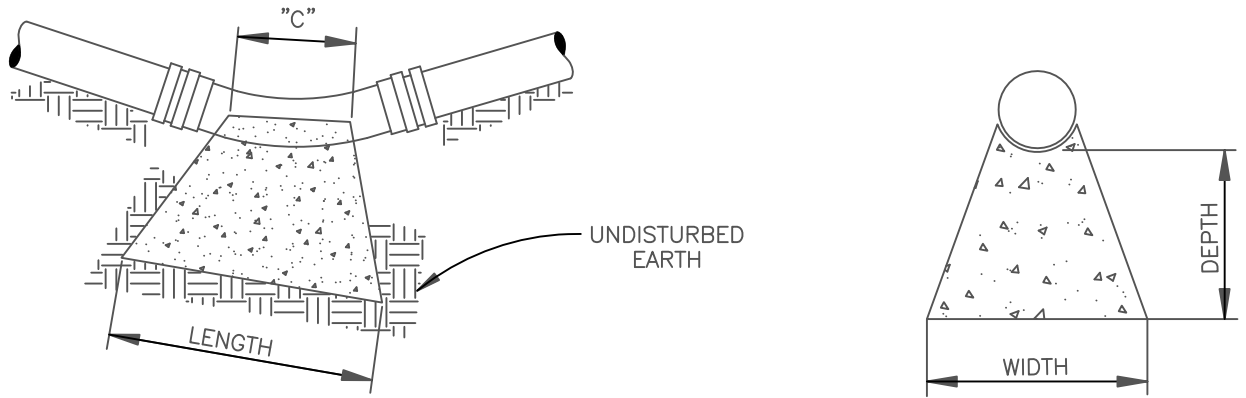

TABLE FOR CONCRETE BLOCKING  
(250 PSI TEST PRESSURE)

MINIMUM DIMENSIONS OF BLOCKING								
FITTING	SIZE	DEPTH (FT.)	LENGTH (FT.)	"C" (IN.)	WIDTH (FT.)	VOLUME (C.Y.)	THRUST (LB.)	
11 1/4° BEND	6"	1.0	2.0	6	1.0	0.04	1,385	
11 1/4° BEND	8"	1.0	2.0	7	1.0	0.05	2,465	
11 1/4° BEND	10"	1.0	2.0	9	1.0	0.07	3,850	
11 1/4° BEND	12"	1.0	2.5	11	1.5	0.12	5,550	
11 1/4° BEND	16"	2.0	2.5	12	2.1	0.26	9,860	
11 1/4° BEND	20"	2.0	3.5	15	2.5	0.48	15,406	
11 1/4° BEND	24"	2.0	4.0	18	3.0	0.70	22,185	
22 1/2° BEND	6"	1.0	2.0	6	1.0	0.04	2,760	
22 1/2° BEND	8"	1.0	2.0	7	1.5	0.06	4,905	
22 1/2° BEND	10"	1.0	2.0	9	2.0	0.10	7,665	
22 1/2° BEND	12"	1.0	3.0	11	2.0	0.16	11,040	
22 1/2° BEND	16"	2.0	3.5	12	3.0	0.45	19,625	
22 1/2° BEND	20"	2.0	4.0	15	4.0	0.74	30,665	
22 1/2° BEND	24"	3.0	5.0	18	4.5	1.47	44,160	
45° BEND	6"	1.0	2.0	6	1.5	0.06	5,415	
45° BEND	8"	1.0	2.5	7	2.0	0.10	9,625	
45° BEND	10"	2.0	3.5	9	2.5	0.31	15,040	
45° BEND	12"	2.0	3.5	11	3.0	0.41	21,655	
45° BEND	16"	3.0	5.0	12	4.0	1.45	38,495	
45° BEND	20"	4.0	6.0	15	5.0	2.05	60,145	
45° BEND	24"	4.0	7.5	18	6.5	3.35	91,610	
90° BEND	6"	1.0	2.5	12	2.0	0.13	10,005	
90° BEND	8"	2.0	3.0	14	3.0	0.38	17,785	
90° BEND	10"	2.5	4.5	18	3.0	0.74	27,785	
90° BEND	12"	3.0	5.0	20	4.0	1.24	40,000	
90° BEND	16"	4.0	6.5	26	5.5	2.91	71,125	
90° BEND	20"	4.0	8.0	32	7.0	4.68	111,135	
90° BEND	24"	5.0	10.0	40	8.0	8.50	160,035	

NOTES:

1. SOIL BEARING STRENGTH OF 2000 PSI IS ASSUMED IN THE CALCULATIONS ABOVE. ENGINEER SHALL VERIFY.
2. COVER GLANDS AND BOLTS WITH POLYETHYLENE BEFORE PLACING CONCRETE.
3. ALLOW CONCRETE TO SET UP A MINIMUM OF 6 HOURS BEFORE PLACING BACKFILL.
4. CONCRETE SHALL BE 3000 PSI, CLASS A.
5. ALL IRON FITTINGS SHALL BE BLOCKED AND SUPPORTED AS SHOWN ABOVE.

CONCRETE BLOCKING—VERTICAL BENDS—DOWNWARD THRUST

<b>CHEROKEE COUNTY WATER &amp; SEWERAGE AUTHORITY</b>	<b>CONCRETE BLOCKING DETAIL</b>  CONSTRUCTION STANDARD	DATE: FEB. '03	STANDARD NO.  <b>W713</b>
		APPROVED:	

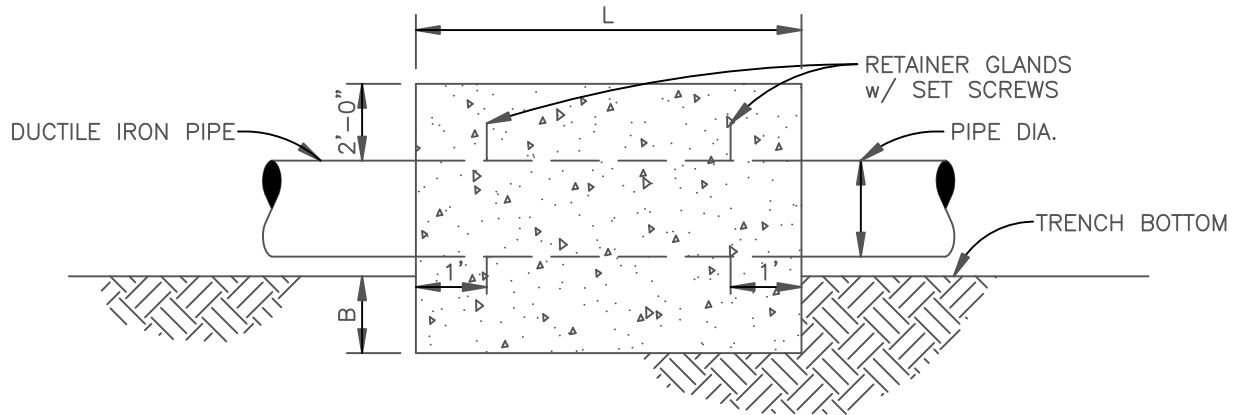

PROFILE VIEW

PIPE DIA.	L	B
6"	4'	1'
8"	4'	1'
10"	4'	1'
12"	4'	1'
16"	4'	2'

NOTE:  
 CONCRETE COLLAR WIDTH EQUALS THE WIDTH OF THE TRENCH PLUS FOUR FEET (TWO FEET ON EACH SIDE OF THE TRENCH).

CONCRETE THRUST COLLAR

<b>CHEROKEE COUNTY          WATER &amp; SEWERAGE          AUTHORITY</b>	<b>CONCRETE          THRUST          COLLAR</b> CONSTRUCTION STANDARD	DATE: FEB. '03	STANDARD NO. <b>W714</b>
		APPROVED:	

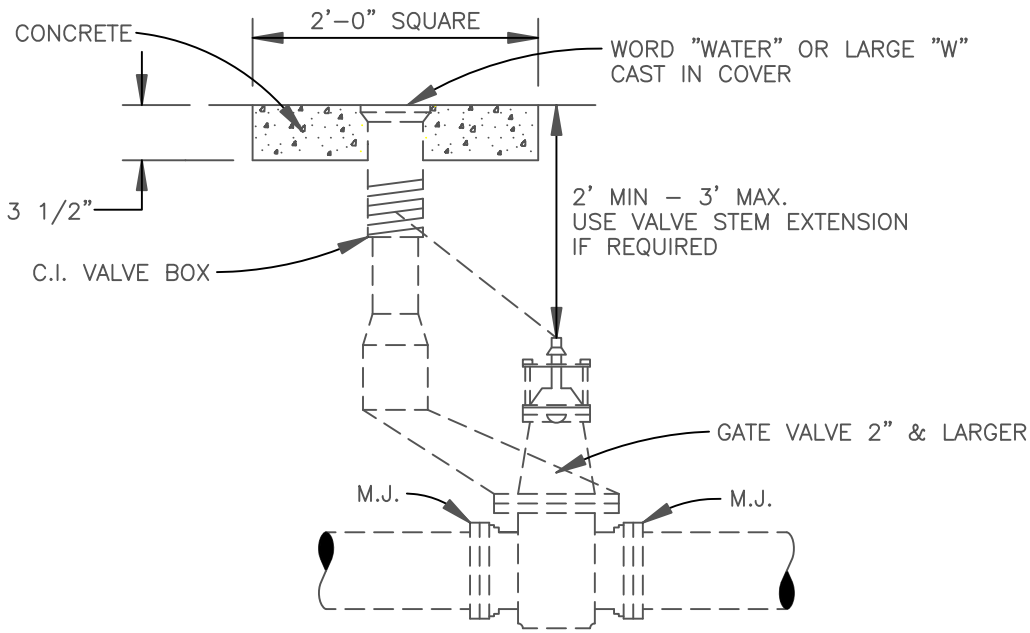

## TYPICAL VALVE INSTALLATION

NOTES:

1. TOP OF EXTENSION SHALL BE NO MORE THAN THREE FEET BELOW FINAL GRADE.
2. CONTRACTOR IS RESPONSIBLE FOR IN FIELD MEASUREMENT OF DEPTH OF PIPE COVER TO DETERMINE NEED FOR VALVE STEM EXTENSION.

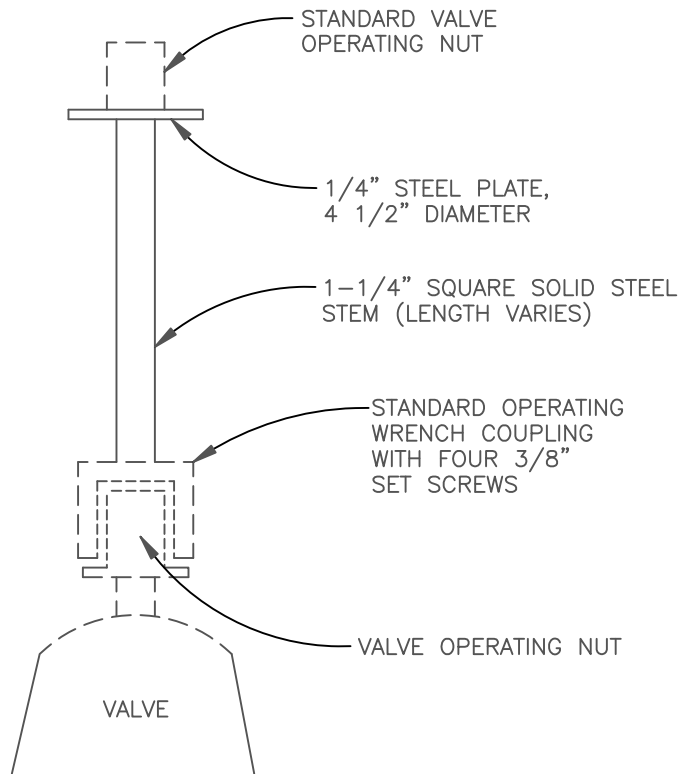

## VALVE STEM EXTENSION DETAIL

**CHEROKEE COUNTY  
WATER & SEWERAGE  
AUTHORITY**

**TYPICAL  
VALVE  
INSTALLATION**  
CONSTRUCTION STANDARD

DATE: FEB. '03

APPROVED:

STANDARD  
NO.  
**W715**

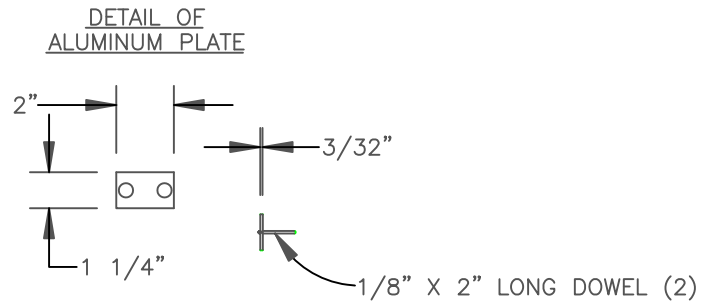
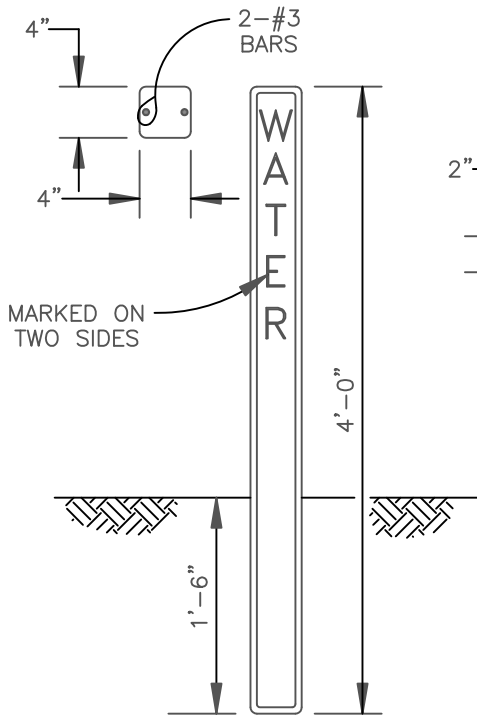

NOTES:

1. ALUMINUM PLATE CAST IN SIDE OF MARKER POST.
2. DISTANCE (NEAREST FOOT) FROM  $\phi$  OF POST TO  $\phi$  OF VALVE BOX AND DIRECTION ARROW TO BE STAMPED INTO PLATE WITH STEEL DIE AFTER MARKER IS SET.

DETAIL OF CONCRETE VALVE MARKER

<b>CHEROKEE COUNTY WATER &amp; SEWERAGE AUTHORITY</b>	<b>CONCRETE VALVE MARKER</b> CONSTRUCTION STANDARD	DATE: FEB. '03	STANDARD NO. <b>W716</b>
		APPROVED:	

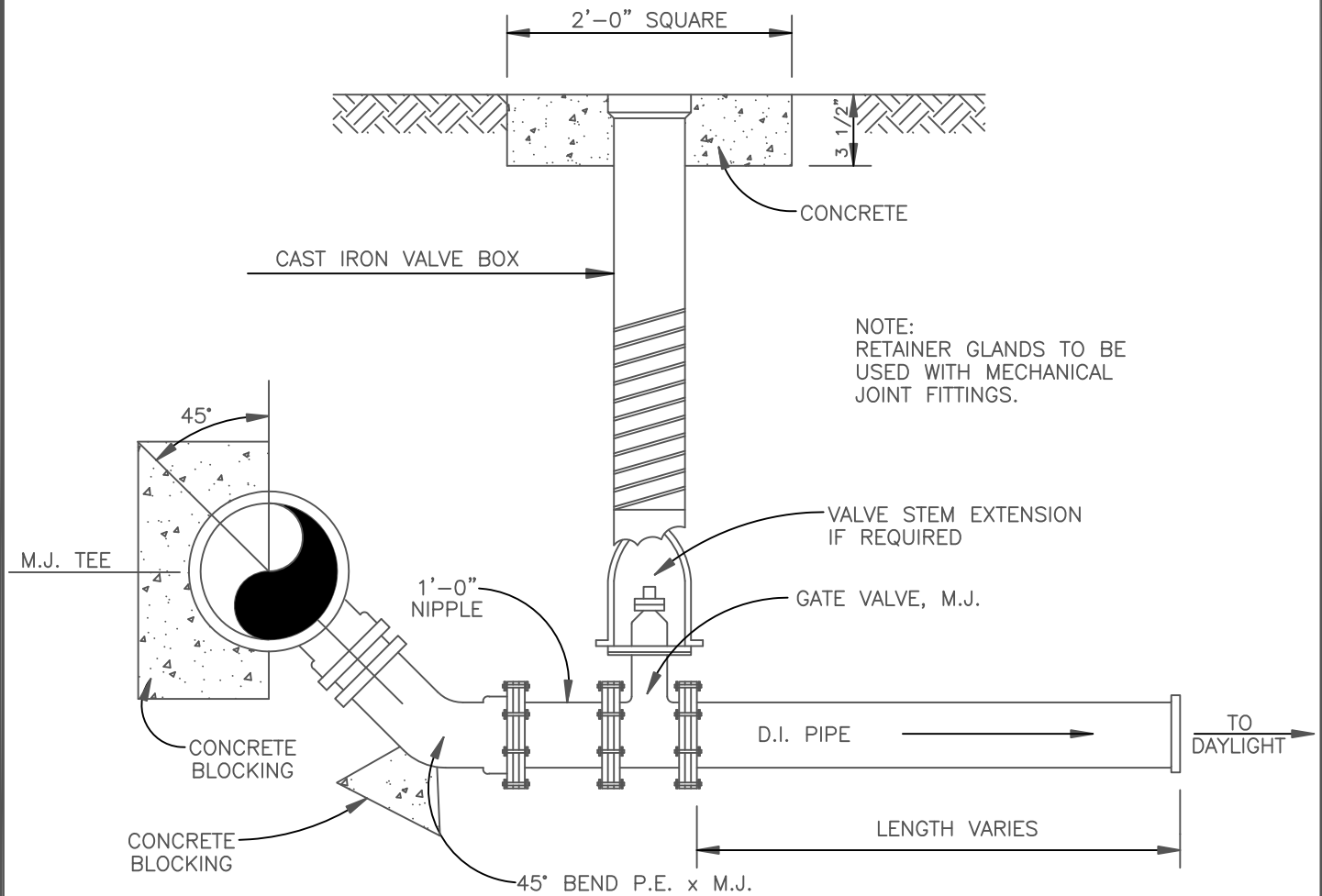

## BLOW-OFF ASSEMBLY

NOT TO SCALE

<b>CHEROKEE COUNTY WATER &amp; SEWERAGE AUTHORITY</b>	<b>BLOW-OFF ASSEMBLY</b>  CONSTRUCTION STANDARD	DATE:	FEB. '03	STANDARD NO.  <b>W717</b>
		APPROVED:		

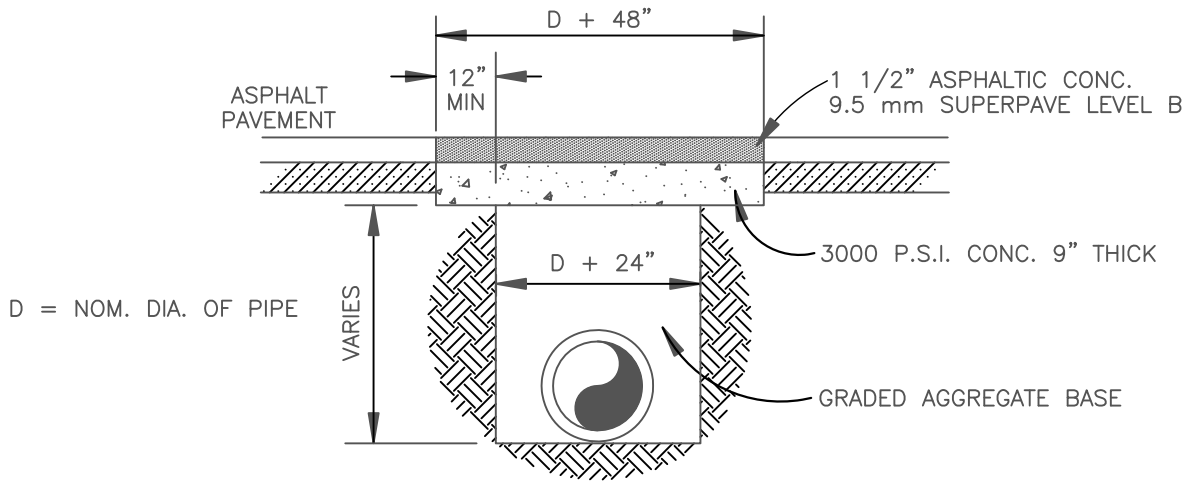

## STATE OR STATE-AID ROADS

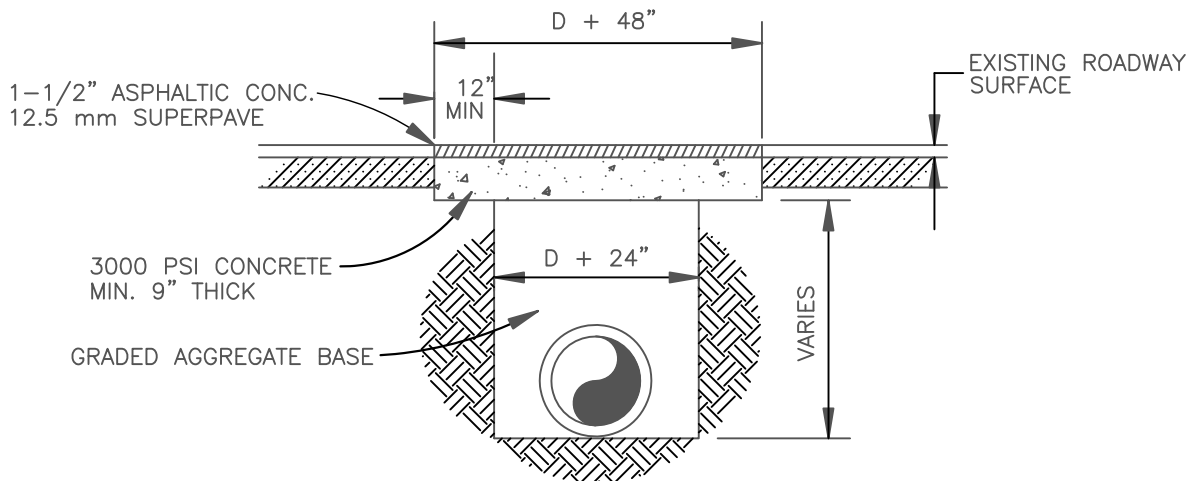

**NOTES:**

1. PERMISSION MUST BE OBTAINED FROM CHEROKEE COUNTY TO OPEN CUT EXISTING ROADS.
2. ROADWAYS WILL GENERALLY BE BORED OR TUNNELED FROM DITCH LINE TO DITCH LINE.
3. IF CONCRETE PAVEMENT, REPLACE WITH ORIGINAL THICKNESS (MINIMUM 8"), FLUSH WITH EXISTING PAVEMENT.
4. COMPACTION REQUIREMENTS: 95% STD. PROCTOR FROM PIPE BEDDING TO 1' BELOW GRADE.  
100% STD. PROCTOR FOR TOP 1' OF TRENCH.

## COUNTY ROADS

**CHEROKEE COUNTY  
WATER & SEWERAGE  
AUTHORITY**

**TYPICAL STREET  
CUT REPAIR**  
CONSTRUCTION STANDARD

DATE: MAR. '04

APPROVED:

STANDARD  
NO.  
**W718**

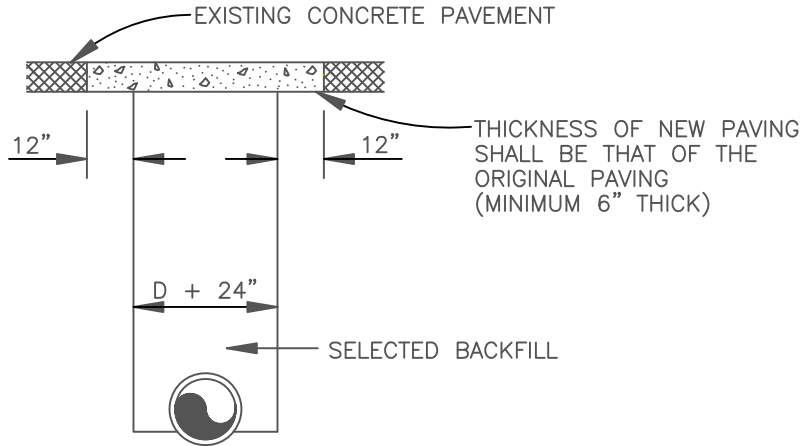

## CONCRETE DRIVEWAY

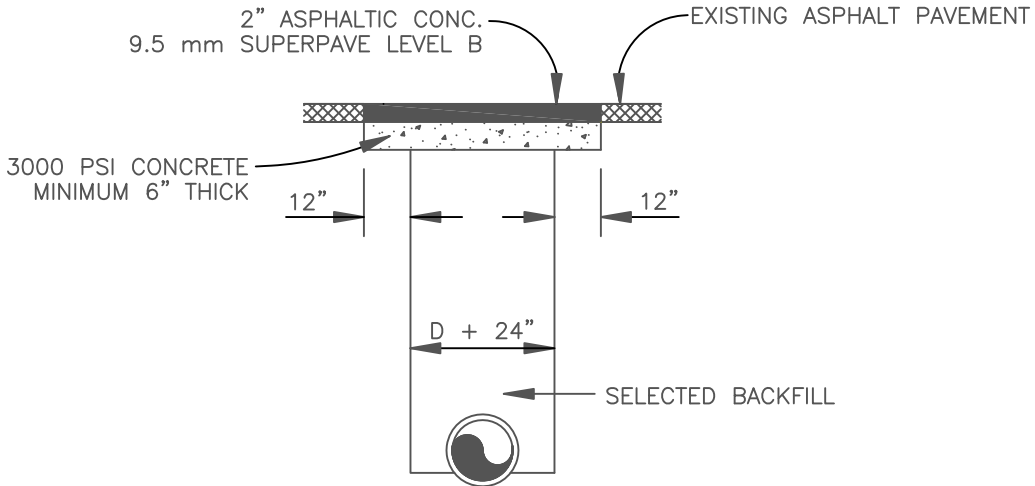

## ASPHALT DRIVEWAY

**NOTES:**

1. BACKFILL TO BE COMPACTED AS DIRECTED IN SPECIFICATIONS.
2. D = NOMINAL PIPE DIAMETER
3. COMPACTION REQUIREMENTS: 95% STD. PROCTOR FROM PIPE BEDDING TO 1' BELOW GRADE.  
100% STD. PROCTOR FOR TOP 1' OF TRENCH.

**CHEROKEE COUNTY  
WATER & SEWERAGE  
AUTHORITY**

**TYPICAL  
DRIVEWAY  
CUT REPAIR  
CONSTRUCTION STANDARD**

DATE:	MAR. '04
APPROVED:	

STANDARD  
NO.  
**W719**



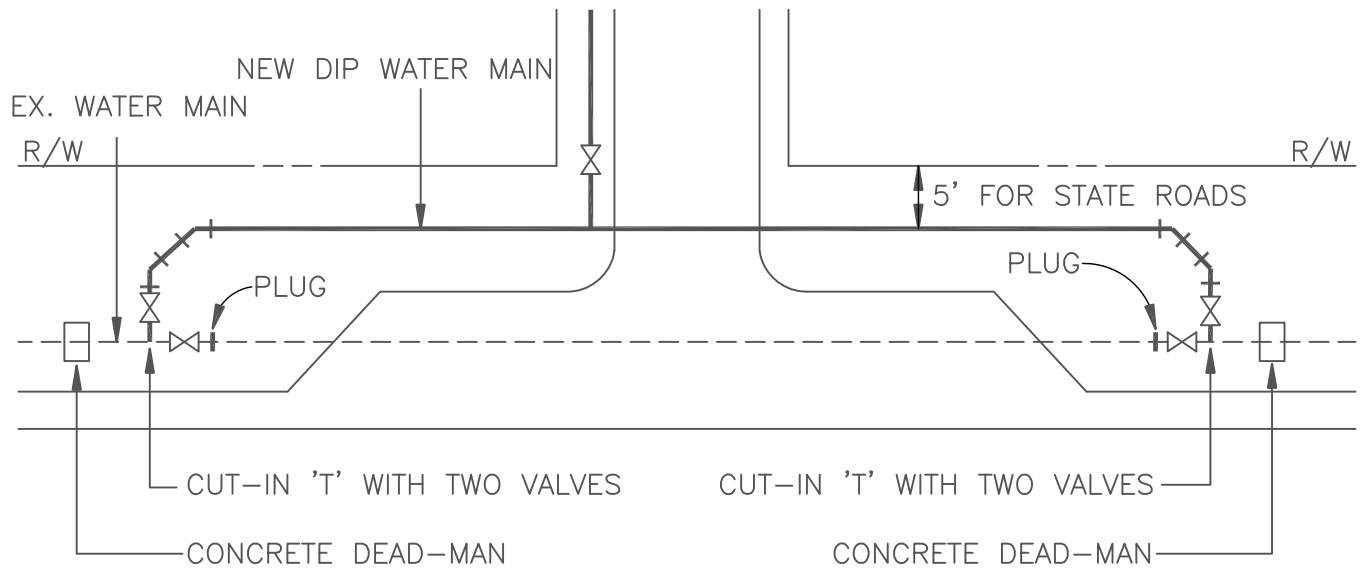

4 DAY NOTICE TO ALL CUSTOMERS

THE SECTION OF WATER MAIN THAT REMAINS UNDER ANY IMPERVIOUS SURFACE. ANY IMPERVIOUS SURFACE.

- =EX. MAIN
- =PROP. MAIN
- ⊗ =VALVE

NOTES:

1. THE LOCATION OF THE NEW DIP WATER MAIN IS DEPENDENT ON WHETHER THE ROAD IS A STATE ROUTE OR A COUNTY ROAD.
2. SOME VALVES MAY BE ELIMINATED DEPENDING UPON FLOWS.
2. DEVELOPER HAS THE OPTION TO REMOVE OR GROUT THE SECTION OF WATERMAIN THAT REMAINS UNDER ANY IMPERVIOUS SURFACE.  
(SEE DETAIL W-723 FOR APPROVED GROUT METHOD)

<b>CHEROKEE COUNTY WATER &amp; SEWERAGE AUTHORITY</b>	<b>TURN LANE RELOCATION DETAIL</b> CONSTRUCTION STANDARD	DATE:	MAR. '04	STANDARD NO.  <b>W720</b>
		APPROVED:		

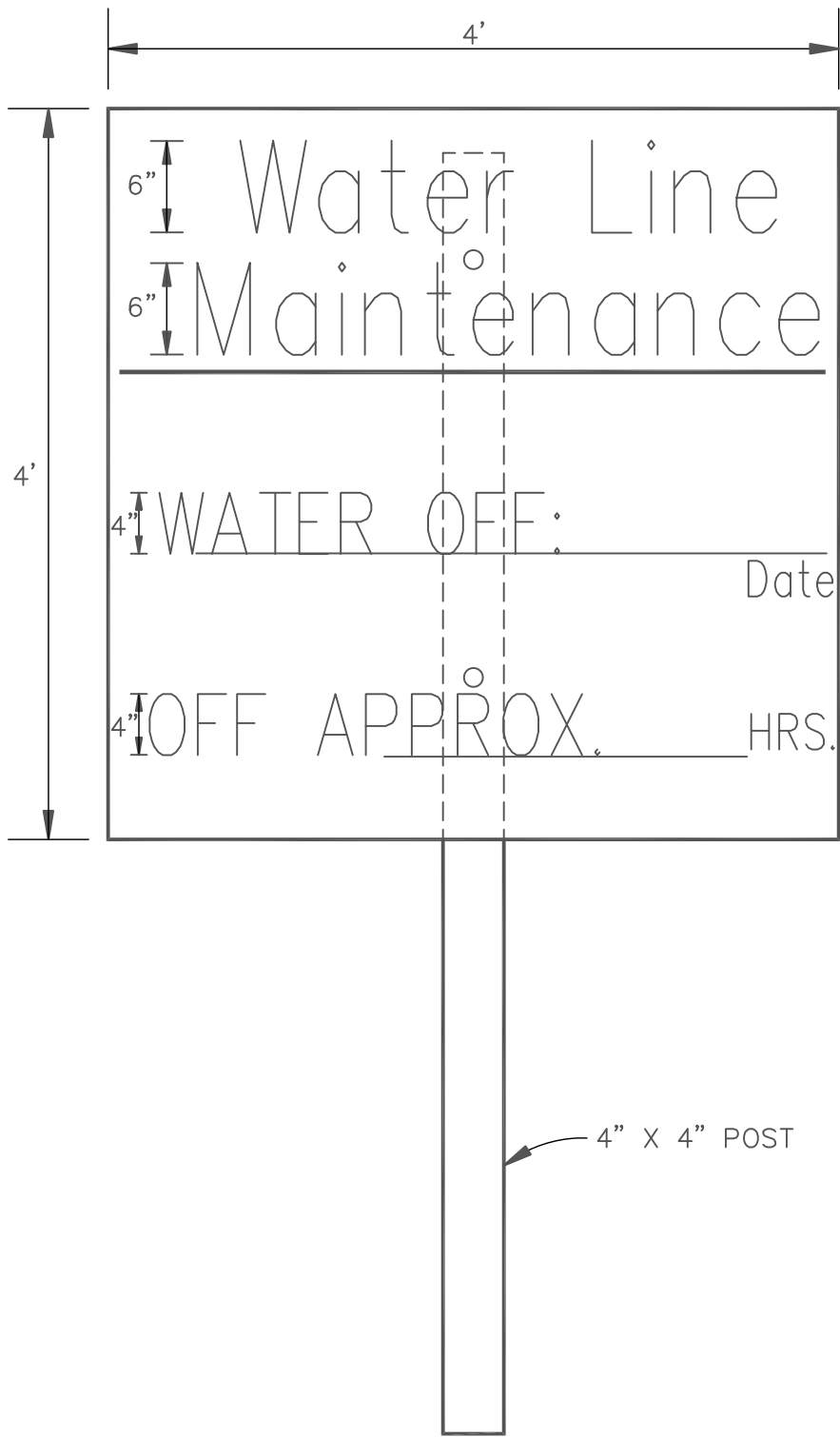

4" X 4" POST

**CHEROKEE COUNTY  
WATER & SEWERAGE  
AUTHORITY**

**WATER LINE  
MAINTENANCE  
SIGN**  
CONSTRUCTION STANDARD

DATE:	FEB. '03
APPROVED:	

STANDARD  
NO.  
**W721**

**Detail W722**

***Cherokee County Water & Sewerage Authority***

P.O. Box 5000 Canton, Georgia 30114  
Phone: (770) 479-1813 Fax: (770) 704-0053

**New Project Requirement Detail (2010)**

This is a list of some of the requirements that need to be met before obtaining water and/or sewer service in Cherokee County.

- A pre-construction meeting with water and/or sewer contractor and C.C.W.S.A inspector before work begins. (770) 479-9107
- Contractor must have approved plans stamped by C.C.W.S.A before water or sewer work begins.
- There are certain fees, depending on type of project, which must be paid to C.C.W.S.A. before getting service. Some of which are:

**Water Flow Test \$400.00**  
 (Fees must be paid before test can be ordered)  
**Plan Review Fees:**  
**Water \$250.00**  
**Sewer \$500.00**  
**Lift Station \$10,000.00**  
**(FEES ARE SUBJECT TO CHANGE)**

Water Meter Deposit (Depends on size of meter and/or number of units.)

Back-Flow Device (Depends on size and type), when testable device is required we also must have test result by approved tester before setting of meter. Contact: Greg Long (770) 479-9107 ext. 228

Sewer Tap Fee (depends on size and type) Contact: Ricky Dobbs (770) 479-1813 ext 249

- If meter is larger than 2" meter must have a by-pass.(All fees paid before tapping)
- Must submit five sets of As-Built Plans & Electronic Data (On State Plane Coordinates) to Rose Creek Plant for all proposed projects. Contact: Jeff Hooper or Corey Ghorley (770) 591-7156

All sanitary sewer manholes in streets shall be required to be @ 95% compaction under the first foot of top grade. Compaction tests shall be at all 4' lifts on 2 sides of each manhole within a 2' diameter of the manhole. Test results shall be faxed to C.C.W.S.A. Inspection Department before any G.A.B. shall be placed on sub-grade.

C.C.W.S.A. Fax: (770) 704-0053  
(This applies to county projects only. Not projects within city limits)

If the proposed project will serve, or has the potential to serve a business that is required to have a grease trap or dumpster pad, plans for the same will be submitted to C.C.W.S.A. Inspection Department: Marty Rodgers (770) 479-9107 ext. 223

- Any and all final tests on water and sewer, and all fees paid, before final plat can be signed or release of meters.
- Maintenance Bonds must be posted.
- Once job is released, owner/developer will be responsible for one year warranty period.
- Must be two separate signature places on final plat for C.C.W.S.A. to sign off.
- Project will not be released for meter sales until C.C.W.S.A. Inspection Department has received two copies of recorded final plat along with a PDF file.
- At end of one year re-inspection will be done.
- If water has to be cut off, work needs to be scheduled 4 to 5 days ahead of time. Phone: (770) 479-9107
- CANNOT ENCROACH ON ANY BUFFERS, OWNER/DEVELOPER & ENGINEER WILL BE RESPONSIBLE FOR OBTAINING VARIANCES.(Must have in writing where variance was obtained)

Signature \_\_\_\_\_ Date \_\_\_\_\_

2" BRASS BALL VALVE

3/4" CURBSTOP

2"GALV. PIPE

2"GALV. COUPLING AT GROUND LEVEL

3/4" SERVICE

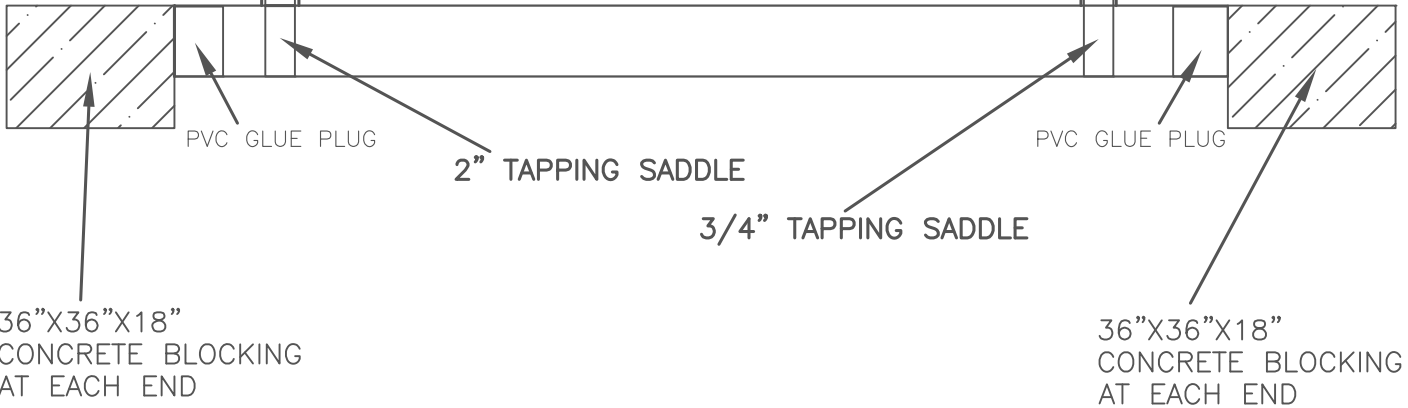

PVC GLUE PLUG

2" TAPPING SADDLE

PVC GLUE PLUG

3/4" TAPPING SADDLE

36"x36"x18"  
CONCRETE BLOCKING  
AT EACH END

36"x36"x18"  
CONCRETE BLOCKING  
AT EACH END

**CHEROKEE COUNTY  
WATER & SEWERAGE  
AUTHORITY**

**WATER LINE  
GROUT  
DETAIL**  
CONSTRUCTION STANDARD

DATE: DEC. 09

APPROVED:

STANDARD  
NO.  
**W723**

10' CCWSA  
EASEMENT

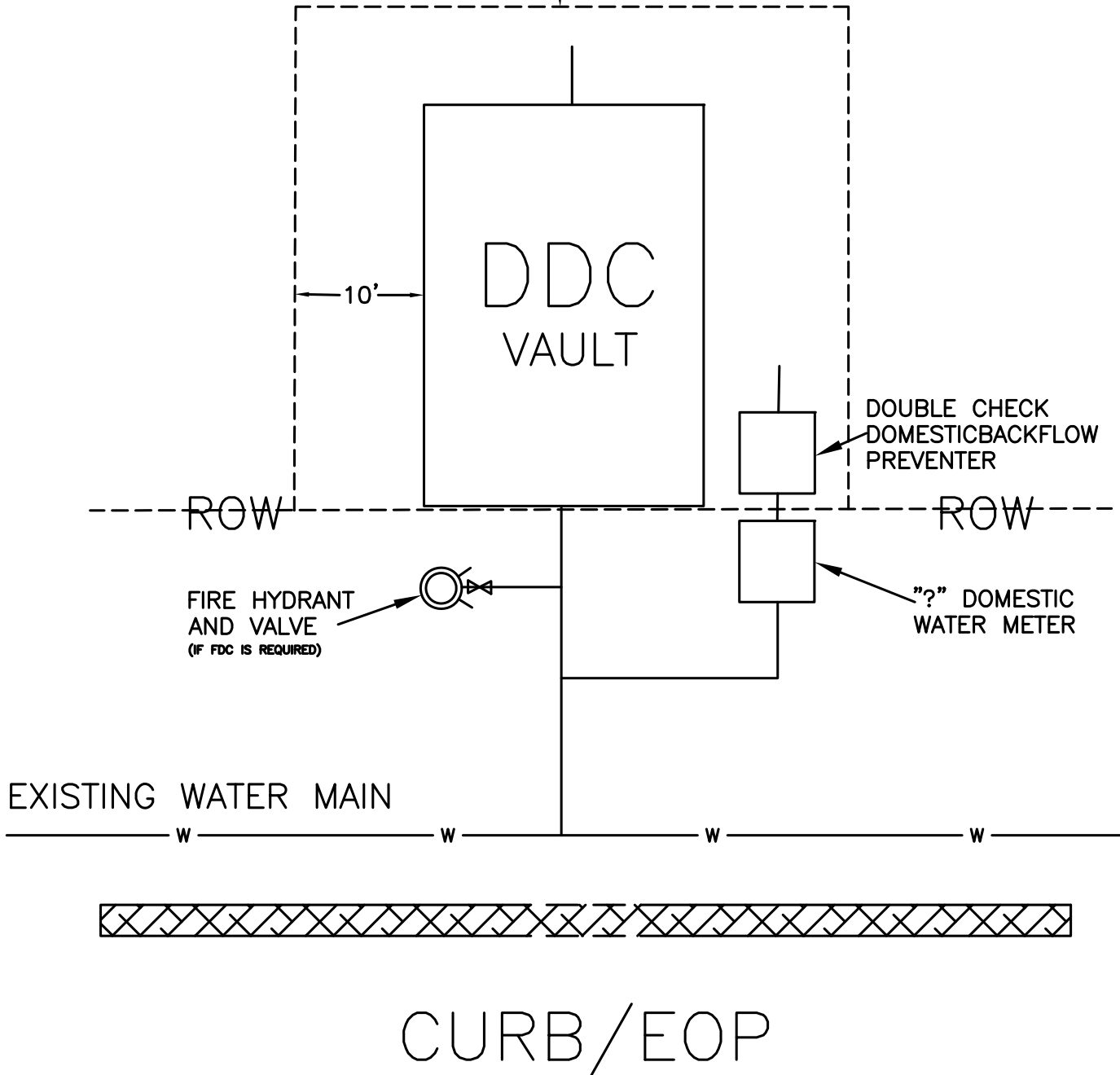

CHEROKEE COUNTY  
WATER & SEWERAGE  
AUTHORITY

BACKFLOW AND/  
EASEMENT  
DETAIL  
CONSTRUCTION STANDARD

DATE: DEC. 09

APPROVED:

STANDARD  
NO.  
W724

DETAIL W725

**COLOR CODES  
FOR  
UTILITY LOCATING**

**RED** ELECTRIC

**YELLOW** GAS-OIL

**ORANGE** TELEPHONE/CATV

**BLUE** WATER

**GREEN** SEWER

**IF YOU DIG GEORGIA**

**CALL US FIRST !**

1-800-282-7411

*It's The Law !*

**Utilities Protection Center, Inc.**

**THREE WORKING DAYS  
BEFORE  
YOU DIG GEORGIA  
CALL**

**Utilities Protection  
Center, Inc.**



**1-800-282-7411**

*It's The Law !*

## **DETAIL W730 – PAGE 1 of 3**

### **CHEROKEE COUNTY WATER AND SEWERAGE AUTHORITY POTABLE WATER SYSTEM CONSTRUCTION GENERAL NOTES**

1. All potable water system construction must follow the current Cherokee County Water and Sewerage Authority Water Main Standards.
2. All water mains shall be ductile iron pipe, except where the Construction Manager approves otherwise. Ductile iron pipe shall be thickness Class 50, designed in accordance with AWWA C150 and manufactured in accordance with AWWA C151. All ductile iron pipe shall have an outside bituminous coating per AWWA C151 and an inside standard cement lining with bituminous seal coat per AWWA C104. All references to AWWA standards shall mean latest revisions published.
3. All line valves shall be marked by concrete valve markers and by a "V" cut into the curbing, with the point of the "V" aimed at the valve.
4. A concrete valve marker is to be placed directly above the plug on all dead-end water mains.
5. Information regarding underground utilities on these plans is not guaranteed as to accuracy or completeness. Prior to beginning work, the Contractor shall request a field location through the utilities protection center and any utility owners thought to have facilities in the area. The Contractor shall promptly compare these field-marked locations with the project plans and then notify the Designer of any anticipated problems or need for contract changes. It is the Contractor's responsibility to excavate or cause the utility owner to excavate for the purpose of determining exact elevations or locations at utility crossings and other critical locations well in advance of the work under this contract. Damage to existing utilities resulting from the Contractor's negligence shall be repaired at the Contractor's expense.
6. All service lines under pavement shall be encased in Schedule 40 PVC casing with a minimum diameter of 2", extending a minimum of 3 feet beyond the pavement and/or sidewalk on each side of the road. 2" services shall be encased in 4" PVC casings. All water service laterals 2" and smaller shall be Type K copper tubing with compression fittings as specified in the Water Standards.
7. Concrete thrust blocking shall be placed at all bends, tees, valves, reducers and all other fittings. Prior to blocking, fittings shall be wrapped with polyethylene film.
8. The Developer/Contractor shall meet with the Chief Inspector at least 24 hours before beginning construction. The Contractor shall notify the Chief Inspector or his designated representative by 8:30 a.m. of each workday when work is scheduled unless authorized otherwise.
9. Water mains shall be installed so that the top of the pipe is a minimum of four feet below final grade, four feet below the edge of the pavement, or four feet below the ditch paralleling the road, whichever is deepest.
10. Contractor shall place a vertical piece of 2" PVC pipe on top of the water main at all tees, bends, fittings, elevation transitions, and every fifty feet along the length of the main for the purpose of collecting elevation data for record drawings. The top of the 2" PVC shall be capped or taped to prevent dirt and other debris from clogging the 2" pipe before the depth can be measured.
11. All fittings and valves are to be mechanical joint with retainer glands unless otherwise approved. Retainer glands shall be EBAA Mega-Lug or approved equal.

## **DETAIL W730 – PAGE 2 of 3**

12. Type 4 bedding is required at all restrained pipe installations.
13. Contractor must show proof of insurance in the amount specified by the CCWSA.
14. All backflow preventer devices are to be tested by a CCWSA approved tester. A list of testers is available from the CCWSA. Any tester not on the list is subject to approval by the CCWSA. Contact Mr. Greg Long with the CCWSA for more information.
15. All meters, backflow preventers and double detector check valve assemblies are to be purchased from the CCWSA.
16. A horizontal separation of at least 10 feet is required between existing or proposed water mains and existing or proposed sanitary sewer lines.
17. A vertical separation of at least 18 inches is required where a water main crosses an existing or proposed sanitary sewer line. A full joint of water main is required to be centered at the sanitary sewer line crossing.
18. No portion of this project is being constructed on or near an existing landfill, abandoned landfill, or any other site used for waste disposal.
19. Potable water and sanitary sewer structures are not allowed within a dam. Utility pipelines and structures must be a minimum of 30 feet outside the toe of slope of the dam.
20. Hydrant flow tests are valid for one year and only apply to a single phase of this project.
21. Existing County roads shall not be open cut unless permission is granted by the Cherokee County Department of Public Transportation.
22. Plan approval is valid for 12 months without beginning construction. Plans shall be subject to beginning the process of review and approval if 12 months expire prior to the start of construction.
23. Record drawings of water and sanitary sewer facilities are required to be submitted to the CCWSA upon completion of the project.
24. If construction plans are stamped for a full project, and then the Developer revises the plans to build the development in phases, no construction or field inspection will be allowed to begin until the revised, phased plans are re-approved and stamped for the phased construction.
25. If an existing water main is to be paved over by a new entrance or accel/decel lanes, the water main is to be abandoned and replaced with a new DIP water main located five feet or more behind the new back of curb.
26. New water mains installed along County or State roads, within 80 feet of steel gas main crossings, or in any wetland areas must be encased in polyethylene tubing (Polywrap 8 mil).
27. All streams and protective buffers shall be crossed in accordance with current County and State regulations.
28. Fire hydrants shall be designed to be placed within 200 feet of new entrances, in all cul-de-sacs, and at every proposed intersection.



**DETAIL W730 – PAGE 3 of 3**

29. New fire hydrants shall be Mueller Super Centurion 250, M&H AWWA C502 Style 129 Traffic Model, or US Pipe Metropolitan 250 Model 94. All hydrants shall be rated for 250 psi working pressure and shall be equipped with a 5¼" valve opening, two 2½" hose nozzles and one 4½" pumper nozzle.
30. Inside of steel casings, pipe joints shall be restrained using Fast-Grip gaskets or approved equal.
31. All new water mains must pass leakage testing and disinfection testing witnessed by a CCWSA representative before a project is released and accepted.
32. All water meter vaults and DDCV assembly vaults are to be located off of the road right-of-way in a permanent easement dedicated to the CCWSA. The easement shall be dimensioned to be 10 feet off each corner of the vault. Smaller domestic use meters adjacent to a DDCV assembly can be located within the 10 foot spacing between the vault and the edge of the easement.
33. Inside of developments with curb and gutter, the Contractor shall cut a "V" into the top of the curb for all water valves (line valves and hydrant valves) with the point of the "V" aimed at the valve. The Contractor shall also cut a "W" in the top of the curb above all water service laterals.
34. The report stating the results of the hydrant flow test and the 24 hour pressure recording chart shall be shown within the plans for this project.
35. Horizontal locations will be referenced to Georgia State Plane Coordinates System (NAD 83 West Zone Feet).
36. Vertical locations will be referenced to North American Vertical Datum (NAVD 88).
37. Orthometric locations will be referenced to GEOID 99/03.
38. No landscaping or structures will be allowed in CCWSA easements.
39. Contractor shall provide meter stubs.



# CERTIFICATE OF LIABILITY INSURANCE

DATE (MM/DD/YYYY)  
01/01/2010

<b>PRODUCER</b>  Insurnce Agent/Broker Name Insurnce Agent/Broker Street Address or P.O. Box Insurnce Agent/Broker City, State & Zip Code Contact & Phone Number	<b>THIS CERTIFICATE IS ISSUED AS A MATTER OF INFORMATION ONLY AND CONFERS NO RIGHTS UPON THE CERTIFICATE HOLDER. THIS CERTIFICATE DOES NOT AMEND, EXTEND OR ALTER THE COVERAGE AFFORDED BY THE POLICIES BELOW.</b>	
	<b>INSURERS AFFORDING COVERAGE</b>	<b>NAIC #</b>
<b>INSURED</b>  Contractor/Vendor Name Contractor/Vendor Street Address or P.O. Box Contractor/Vendor City, State & Zip Code	INSURER A: Name of Insurance Company	Enter NAIC#
	INSURER B: Name of Insurance Company (if applicable)	Enter NAIC#
	INSURER C: Name of Insurance Company (if applicable)	Enter NAIC#
	INSURER D: Name of Insurance Company (if applicable)	Enter NAIC#
	INSURER E: Name of Insurance Company (if applicable)	Enter NAIC#

### COVERAGES

THE POLICIES OF INSURANCE LISTED BELOW HAVE BEEN ISSUED TO THE INSURED NAMED ABOVE FOR THE POLICY PERIOD INDICATED. NOTWITHSTANDING ANY REQUIREMENT, TERM OR CONDITION OF ANY CONTRACT OR OTHER DOCUMENT WITH RESPECT TO WHICH THIS CERTIFICATE MAY BE ISSUED OR MAY PERTAIN, THE INSURANCE AFFORDED BY THE POLICIES DESCRIBED HEREIN IS SUBJECT TO ALL THE TERMS, EXCLUSIONS AND CONDITIONS OF SUCH POLICIES. AGGREGATE LIMITS SHOWN MAY HAVE BEEN REDUCED BY PAID CLAIMS.

INSR LTR	ADD'L INSRD	TYPE OF INSURANCE	POLICY NUMBER	POLICY EFFECTIVE DATE (MM/DD/YY)	POLICY EXPIRATION DATE (MM/DD/YY)	LIMITS	
A	<input checked="" type="checkbox"/>	<b>GENERAL LIABILITY</b> <input checked="" type="checkbox"/> COMMERCIAL GENERAL LIABILITY <input type="checkbox"/> CLAIMS MADE <input checked="" type="checkbox"/> OCCUR <input checked="" type="checkbox"/> Contractual <input checked="" type="checkbox"/> XCU (explosion, underground, collapse) GEN'L AGGREGATE LIMIT APPLIES PER: <input type="checkbox"/> POLICY <input checked="" type="checkbox"/> PROJECT <input type="checkbox"/> LOC	Enter Policy #	Enter Effective Date	Enter Expiration Date	EACH OCCURENCE	\$1,000,000
						DAMAGE TO RENTED PREMISES (Ea occurrence)	\$100,000
						MED EXP (Any one person)	\$5,000
						PERSONAL & ADV INJURY	\$1,000,000
						GENERAL AGGREGATE	\$1,000,000
						PRODUCTS - COMP/OP AGG	\$1,000,000
						Fire Damage -Any one fire	\$50,000
A	<input type="checkbox"/>	<b>AUTOMOBILE LIABILITY</b> <input type="checkbox"/> ANY AUTO <input type="checkbox"/> ALL OWNED AUTOS <input type="checkbox"/> SCHEDULED AUTOS <input type="checkbox"/> HIRED AUTOS <input type="checkbox"/> NON-OWNED AUTOS <input type="checkbox"/> _____ <input type="checkbox"/> _____	Enter Policy #	Enter Effective Date	Enter Expiration Date	COMBINED SINGLE LIMIT (Each Occurrence)	\$
						BODILY INJURY (Per person)	\$
						BODILY INJURY (Per accident)	\$
						PROPERTY DAMAGE (Per accident)	\$
A	<input type="checkbox"/>	<b>GARAGE LIABILITY</b> <input type="checkbox"/> ANY AUTO <input type="checkbox"/> _____				AUTO ONLY - EA ACCIDENT	\$
						OTHER THAN EA ACC	\$
						AUTO ONLY: AGG	\$
A	<input type="checkbox"/>	<b>EXCESS/UMBRELLA LIABILITY</b> <input type="checkbox"/> OCCUR <input type="checkbox"/> CLAIMS MADE <input type="checkbox"/> DEDUCTIBLE <input type="checkbox"/> RETENTION \$	Enter Policy #	Enter Effective Date	Enter Expiration Date	EACH OCCURENCE	\$
						AGGREGATE	\$
							\$
							\$
							\$
A	<input checked="" type="checkbox"/>	<b>WORKERS COMPENSATION AND EMPLOYERS' LIABILITY</b> ANY PROPRIETOR/PARTNER/EXECUTIVE OFFICER/MEMBER EXCLUDED? If yes, describe under SPECIAL PROVISIONS below	Enter Policy #  (Policy must meet statutory requirements)	Enter Effective Date	Enter Expiration Date	<input checked="" type="checkbox"/> WC STATUTORY LIMITS <input type="checkbox"/> OTHER	
						E.L. EACH ACCIDENT	\$1,000,000
						E.L. DISEASE - EA EMPLOYEE	\$1,000,000
						E.L. DISEASE - POLICY LIMIT	\$1,000,000
	<input type="checkbox"/>	<b>OTHER</b>					

### DESCRIPTION OF OPERATIONS / LOCATIONS / VEHICLES / EXCLUSIONS ADDED BY ENDORSEMENT / SPECIAL PROVISIONS

Cherokee County Water And Sewerage Authority is additional insured.

This/These certificate(s) of insurance conform(s) to all terms and conditions (including coverage of the indemnity agreement) contained in Contract with Cherokee County Water And Sewerage Authority.

Insert Contract, Customer Account, and Purchase Order # (Job Description, if Applicable)

### CERTIFICATE HOLDER

Cherokee County Water And Sewerage Authority  
391 West Main Street  
Canton, GA 30114

### CANCELLATION

SHOULD ANY OF THE ABOVE DESCRIBED POLICIES BE CANCELLED BEFORE THE EXPIRATION DATE THEREOF, THE INSURER AFFORDING COVERAGE WILL ENDEAVOR TO MAIL 30 DAYS WRITTEN NOTICE TO THE CERTIFICATE HOLDER NAMED TO THE LEFT, BUT FAILURE TO DO SO SHALL IMPOSE NO OBLIGATION OR LIABILITY OF ANY KIND UPON THE INSURER, ITS AGENTS OR REPRESENTATIVES.

AUTHORIZED REPRESENTATIVE

## **IMPORTANT**

If the certificate holder is an ADDITIONAL INSURED, the policy(ies) must be endorsed. A statement on this certificate does not confer rights to the certificate holder in lieu of such endorsement(s).

If SUBROGATION IS WAIVED, subject to the terms and conditions of the policy, certain policies may require an endorsement. A statement on this certificate does not confer rights to the certificate holder in lieu of such endorsement(s).

## **DISCLAIMER**

The Certificate of Insurance on the reverse side of this form does not constitute a contract between the issuing insurer(s), authorized representative or producer, and the certificate holder, nor does it affirmatively or negatively amend, extend or alter the coverage afforded by the policies listed thereon.



2010  
SEWER  
SPECIFICATIONS

# **TABLE OF CONTENTS**

## **INTRODUCTION**

### **SECTION 100 - GENERAL INFORMATION**

### **Page**

101.	General Requirements - Use of this Document	100-1
102.	Approval By Other Government Agencies	100-2
103.	List of Commonly Used Terms	100-2
104.	List of Acronyms	100-3
105.	Appeals	100-4
106.	Insurance Requirements	100-4

---

### **SECTION 200 - PLANS**

201.	Preliminary Plan Requirements	200-1
202.	Construction Plan Requirements	200-2
203.	Plan Review Process	200-6
204.	Erosion and Sedimentation Control Plan	200-13
205.	Detail Drawings	200-13
206.	Plan Approval	200-14
207.	Revisions to Approved Plans	200-13
208.	Approval by Other Government Agencies	200-14
209.	Relocation of Existing Water and Sewer Infrastructure	200-15
210.	Easement Acquisition and Utility Encroachment Permits	200-15

---

### **SECTION 300 - DESIGN CRITERIA**

301.	General	300-1
302.	Types Of Sewers and Line Extension Requirements	300-1
303.	Design Period	300-1
304.	Design Factors	300-2
305.	Details of Design and Construction	300-3
306.	Gravity Sewer Pipe	300-4
307.	Slope	300-5
308.	Increasing Size	300-5
309.	Sewer Lines Through Golf Courses	300-6
310.	Sanitary Sewer Force Mains	300-6
311.	Manholes	300-7
312.	Drop Manholes	300-7
313.	Connections to the Authority's Sewer System	300-7
314.	Connections To Existing Manholes	300-8
315.	Steel Casings	300-8
316.	Protection of Water Supply and Other Utilities	300-8

317.	Sewer Services	300-9
318.	Grease Traps and Sand/Oil Traps	300-10
319.	Industrial Sewage Pretreatment	300-10
320.	Dumpster Pad Requirements	300-11

---

## **SECTION 400 – LIFT STATION DESIGN CRITERIA**

401.	General Lift Station Design Specifications	400-1
402.	Pump Requirements	400-1
403.	Wet Well Design	400-2
404.	Check Valve Vaults	400-4
405.	Pump Control Panel	400-5
406.	SCADA Requirements	400-6
407.	Site Requirements	400-7
408.	Emergency Power Requirements	400-8
409.	Generator Transfer Switch	400-15
410.	Wastewater Treatment Plants	400-17

---

## **SECTION 500 - MATERIAL**

501.	General	500-1
502.	Gravity Sewer Pipe	500-1
503.	Sanitary Sewer Force Main	500-10
504.	Precast Concrete Manholes	500-11
505.	Steel Casings	500-14
506.	Stone and Gravel Materials	500-14
507.	Air Release and Vacuum Break	500-14

---

## **SECTION 600 – CONSTRUCTION METHODS**

601.	Excavation General	600-1
602.	Erosion and Sedimentation Control	600-1
603.	Clearing and Grubbing	600-2
604.	Trench Excavation	600-2
605.	Rock Excavation	600-5
606.	Sub-Grade and Pipe Bedding	600-6
607.	Bedding Material	600-8
608.	Installation of Sewer Pipe	600-8
609.	Backfilling Trenches	600-11
610.	Railroad Crossings	600-12
611.	Highway Crossings	600-12
612.	Stream Crossings	600-13
613.	Placing of Steel Casing Pipe	600-14
614.	Replacement of Pavement	600-15
615.	Location and Protection of Existing Utilities	600-16
616.	Clean-Up	600-17
617.	Grassing	600-17
618.	Standard Detailed Drawings	600-18

619.	Pre-Construction	600-18
620.	Barricades	600-19
621.	Fences	600-19
622.	Rip-Rap	600-19

---

## **SECTION 700 – INSPECTION**

701.	Inspection	700-1
702.	Sanitary Sewer System Testing	700-2
703.	Acceptance	700-7
704.	As-Built Drawings	700-10

## **SECTION 800 – SEWER USE and GREASE CONTROL PROGRAM**

801.	Sewer Use Regulations	800-1
802.	Pretreatment Permit Application	800-28
803.	Grease Control Program	800-55
804.	Grease Control Faq	800-63
805.	Grease Control Program User Registration Form	800-65

---

## **SECTION 900 - STANDARD SEWER DETAILED DRAWINGS**

	<u>Detail #</u>
Pre-cast Concrete Manhole	S701
Standard Vented Manhole	S702
Inside Drop Manhole	S703
Safety Platforms	S704
Shallow Manhole	S705
Standard Manhole Plan	S706
Manhole Step	S707
Standard Manhole Frame and Cover – Non-Watertight	S708
Standard Manhole Frame and Cover – Watertight	S709
Manhole Frame - Grade Adjustment	S710
Sewer Service Lateral	S711
Sewer Service Location Detail	S712
Cleanout Detail	S713
Concrete Encasement	S714
Typical Pipe Adapter	S715
Sewer Pipe Anchor (Slopes 20% or More)	S716
Sewer Pipe Class "A" Bedding	S717
Sewer Pipe Class "B" Bedding	S718
Sewer Pipe Class "C" Bedding	S719
Minimum PVC Pipe Bedding	S720
Sewer Air and Vacuum Valve Assembly	S721
Force Main Connection To Manhole	S722
Sewer Casing Spacer	S723
Typical Street Cut Repair	S724
Typical Driveway Cut Repair	S725
Typical Combination Sand/Oil Trap	S726

Typical Grease Trap	S727
Dumpster Pad Detail	S728
Submersible Site Layout Plan	S729
Last Manhole on Sewer Line Before Wet Well	S730
Lift Station Valve Pit Detail	S731
Control Panel / SCADA Opening Detail	S732
Pump Station Grounding	S733
Utility Placement Detail With Curb	S734
Utility Placement Detail Without Curb	S735
New Project Requirement Detail	S736
Sample Certificate of Liability Insurance	S737
“Call Before You Dig” Detail (Page 200-5)	S738
General Notes for Sewer Main Construction (Page 200-6)	S739
Sample Easement for Water Main (Page 200-14)	S740



# **SECTION 100 - GENERAL INFORMATION**

## **101. GENERAL REQUIREMENTS - USE OF THIS DOCUMENT**

- 1.) This document is subject to periodic revision to meet changing requirements for materials, environmental regulations, etc. At the beginning of a project, users should verify that they have the latest edition.
- 2.) This document is intended to convey the general design and construction requirements for a typical project. It also lists specific Cherokee County Water and Sewerage Authority requirements relating to plan review, inspection, testing and acceptance of facilities. It is not intended as a substitute for site-specific engineering and construction techniques. Individual project conditions may require variances from the provisions in this document in which case such variances should be noted in the plans and other data submitted by the project design professional for the Authority's approval.
- 3.) The Standard Details in Section 900 are complementary to the Specifications written herein. If the developer or designer notes any discrepancies or desires an interpretation of a specification, they should submit their question to the Authority in writing for a decision by the Authority or the Authority's representative.
- 4.) Failure by the Authority or the Authority's plan review representative to notice any deviations from the Authority's Standards during the plan review process does not alleviate the Developer's responsibility to adhere to the Standards.
- 5.) The Developer must submit six (6) paper copies of Construction Plans, plus the electronic data on disc, as outlined in these specifications, to the Authority for review.
- 6.) An approved set of construction plans stamped by the Authority must be kept onsite at all times by the Contractor.
- 7.) The Authority shall be notified by the Developer or his contractor before construction begins, and at the various stages in construction as required by the Authority. The Authority shall be given a minimum of 4 days advance notice before an inspection is needed.

## **102. APPROVAL BY OTHER GOVERNMENT AGENCIES**

No part of the approval process is intended to relieve the Developer of the responsibility to comply with minimum standards of the Cherokee County Water & Sewerage Authority, Georgia Department of Natural Resources, EPA, EPD, NRCS, Georgia Department of Transportation, Cherokee County, U.S. Army Corps of Engineers or other appropriate regulatory agency.

## **103. LIST OF COMMONLY USED TERMS**

"Authority" shall mean the Cherokee County Water and Sewerage Authority.

"Contractor" shall mean the individual, firm or corporation undertaking the execution of the Work under the terms of the contract and acting through its agents and employees.

"Developer" shall mean the individual, firm or corporation financing the execution of the Work.

"Engineer" shall refer to the engineer appointed by the Developer as representatives of the Developer and to its properly authorized agents.

"General Manager" shall refer to the General Manager of the Cherokee County Water and Sewerage Authority.

"Chief Inspector" shall refer to the Chief Inspector of the Cherokee County Water and Sewerage Authority.

"Owner" shall refer to the Cherokee County Water and Sewerage Authority.

"Plans" shall refer to those drawings that show the character and scope of the Work and shall include all drawings identified in the contract documents.

"Shall" and "Will" are mandatory; "May" is permissive.

"Specifications" and "Standards" shall refer to the Sanitary Sewer Main Standards of the Cherokee County Water and Sewerage Authority.

"Work" of the contractor shall include all labor, material, equipment, transportation, skills, tools, machinery, and other equipment and things useful and necessary to complete the contract.

## **104. LIST OF ACRONYMS**

ASTM: American Society for Testing and Materials

AWWA: American Water Works Association

DIP.: Ductile Iron Pipe

DOT: Georgia Department of Transportation

EPA: United States Environmental Protection Agency

EPD: Georgia Department of Natural Resources, Environmental Protection Division

CCWSA: Cherokee County Water and Sewerage Authority

HDPE: High Density Polyethylene

NRCS: National Resource Conservation Service

OSHA: United States Dept. of Labor, Occupational Safety and Health Administration

PVC: Polyvinyl Chloride

RCP: Reinforced Concrete Pipe

VCP: Vitrified Clay Pipe

## 105. APPEALS

Any requirement that is outlined in these specifications may be modified or revoked by a majority vote of the full membership of the Cherokee County Water and Sewerage Authority.

Persons wishing to file an appeal must submit a written request to the Authority prior to the Agenda date for the next Authority meeting stating the nature of the request to be made. If the request is not made prior to the Agenda date, it will be considered at the following regularly scheduled meeting of the Authority. Please contact the Authority's office for information regarding the deadline date to be included on the agenda.

## 106. INSURANCE REQUIREMENTS

### **Cherokee County Water And Sewerage Authority**

**3<sup>rd</sup> Party Contractor Hold-Harmless Agreement,  
Insurance, Indemnity, and Additional Insured**

---

#### **3<sup>rd</sup> Party Contractor**

Contractor's Liability Insurance: Contractor shall maintain at its sole cost and expense such insurance as will fully protect it and Cherokee County Water And Sewerage Authority (et al), CCWSA's officials, directors, officers, employees, agents, and volunteers from incidents, accidents, and claims for bodily injury and property damage which may arise from operations under this Contract; whether such operations are performed by Contractor or by any Subcontractor directly employed or retained by either.

#### INDEMNITY AND INSURANCE

##### Commercial Insurance

1. Workers' Compensation Insurance in compliance with the applicable Workers' Compensation Act(s) of the state(s) wherein the work is to be performed or where jurisdiction could apply in amounts required by statutes.
2. Employer's Liability Insurance, with limits of liability of not less than \$1,000,000 for each accident/disease.

3. General Liability Insurance, including contractual liability insurance, explosion and underground collapse (XCU), product and completed operations, personal and advertising injury, damage to rented premises (each occurrence \$100,000), medical expense (any one person \$5,000), fire damage (\$50,000), and any other type of liability for which this Contract applies with limits of liability of not less than \$1,000,000 each occurrence / \$1,000,000 annual aggregate. General Liability Insurance must be written on an “occurrence” form and must apply on at least a per “project” basis.

#### Property Insurance

The Contractor assumes sole responsibility for loss or damage to its property and hereby releases CCWSA and its officials, directors, officers, employees, agents, and volunteers from loss or damage to Contractor and its employee’s tools, equipment, goods, machinery, materials, and supplies.

#### Conditions

The aforementioned insurance policies shall contain a provision that coverages afforded under such policies shall not expire, be canceled or altered without at least thirty (30) days prior written notice to CCWSA’s Risk Management Department. Except for insurance coverages relating to Workers’ Compensation and Employer’s Liability, the foregoing insurance policies shall include an endorsement making Cherokee County Water And Sewerage Authority an Additional Insured under such policies and a clause that insurance is on a primary and non-contributory basis. A copy of the endorsement and clause are to be provided to CCWSA’s Risk Management Department. Certificates of Insurance showing that such coverages are in force shall be filed under this Contract by the Contractor.

The Certificate(s) of Insurance shall also contain a statement as follows:

“This/These certificate(s) of insurance conform(s) to all terms and conditions (including coverage of the indemnity agreement) contained in Contract with Cherokee County Water And Sewerage Authority.”

Such certificates and notices are to be sent to:

**Cherokee County Water And Sewerage Authority  
Attn: Risk Management Department  
391 West Main Street  
Canton, GA 30114**

with a copy to:

**Cherokee County Water And Sewerage Authority  
Attn: Special Projects Department  
583 Cokers Chapel Road  
Ball Ground, GA 30107**

Non-Limitation on Contractor's Liability

The obligations for Contractor to procure and maintain insurance shall not be construed to waive or restrict other obligations and it is understood that insurance in no way limits liability of the Contractor or limits the liability of Contractor whether or not same is covered by insurance.

The Contractor further understands and agrees that any damages, that the Cherokee County Water And Sewerage Authority deems to be a result of said contract work, whether made directly by the Contractor or a Subcontractor thereof, is the sole responsibility of the Contractor and will be repaired, replaced, or recompensed according to specifications in place at the time of discovery.

Insurance Form and Duration

All of the insurance herein specified shall be written on a form acceptable to CCWSA and shall be A.M. Best Company rated B+ 8 or better.

Indemnity

The Contractor agrees to protect, defend, indemnify, save and hold harmless Cherokee County Water And Sewerage Authority, its officials, directors, officers, employees, agents, and volunteers from and against any and all claims, demands, losses, costs, and expenses, and from and against all liability, awards, judgments, and decrees, of whatever nature for any and all damage to property of others and of the parties hereto, their officials, directors, officers, employees, agents, and volunteers, and of whatever nature for any and all injury or injuries (including death) to any person or persons including the officials, directors, agents, employees, agents, and volunteers of the party hereto, arising or in any way growing out of any of the acts or omissions whether of the Contractor, the Contractor's officials, directors, officers, employees, agents, and volunteers or of any tier of the Subcontractor, the tier's officials, officers, directors, employees, agents, and volunteers in connection with the performance of the work under this Contract.

This hold-harmless agreement must be signed and submitted to the CCWSA's Risk Management Department prior to commencement of work.

\_\_\_\_\_  
Contractor

Date

\_\_\_\_\_  
CCWSA Representative

Date

# SECTION 200 - PLANS

## 201. PRELIMINARY PLAN REQUIREMENTS

The following steps apply to the approval for installation of sewer mains, manholes, force mains, lift stations and appurtenances by private developers in commercial, industrial, institutional, residential or other types of developments:

- 1.) Preliminary plans shall include the portion of the county tax maps highlighting the land to be developed, the type of development, the number of units, and the amount of sewage that is expected to be generated, the location and the general plan for sewage collection. The plans shall also include the name, address and telephone number of the Developer or his representative. Questions related to adequate remaining capacity and proposed locations of connections to the existing system should be resolved at this stage before proceeding with detailed planning. The submittal for preliminary review must include all land to be developed although the land is to be developed in several phases or units. Adequacy determinations of the existing sanitary sewer system will be made for the entire project.
- 2.) Developer/Land Owner must submit (3) copies of preliminary plans for any proposed project to the **Special Projects Coordinator and Sewer Coordinator** prior to submitting the construction plans.
- 3.) Sewer availability will be determined by the Authority or a representative of the Authority in the area of the proposed development. The Authority will review the preliminary plans to determine if the wastewater treatment facilities lift stations and sanitary sewer lines in the area of the proposed development have sufficient remaining capacity to serve the proposed development.
- 4.) Comments will then be addressed to the Developer by the Authority relating to the availability of sewer or other items pertinent to the development, such as the need for pretreatment of industrial waste or grease traps.
- 5.) The Developer should procure a copy of the current set of sanitary sewer main standards. It is the Owner/Developer's responsibility to get copies made and distributed to the appropriate Contractors.

## 202. CONSTRUCTION PLAN REQUIREMENTS

The Developer must then submit six (6) paper copies of Construction Plans, (first submittal or revisions) plus the electronic data on disc, as outlined in these specifications to the Authority for review. Electronic data disc shall be submitted with each submittal (first submittal or revisions). Plans and other submittals shall be delivered to the Authority's G.P.S. Department. (See Section 202 for a description of the contents of Construction Plans.) **"These plans must carry the stamp of a registered professional engineer or registered land surveyor."** Included with these plans shall be the National Resource Conservation Service Report of Technical Review . At this time the Developer will also pay the plan review fee for sewer system additions. If this amount is sufficient to cover the Engineer's hourly fee for the complete plan review, no further amount will be charged to the Developer. If the sewer plans are such that the Engineer's fee exceeds the review fee minimum, the Developer will be invoiced for the additional costs at the Engineer's hourly rate. This additional fee must be paid prior to the scheduling of the preconstruction conference. There will also be an additional fee charged if the project requires the plan review of a lift station to serve the development. Consult the Authority regarding the amount of this fee. Fees are subject to increase at any time.

All plans for sanitary sewer projects shall bear a suitable title showing the name of the project, the name of the sewer basin, and show the scale in feet, the north arrow, date, the name of the design professional, the design professional's signature and his registration stamp. All design professionals preparing construction plans and specifications must be registered in the State of Georgia as a professional engineer or a registered land surveyor. If the project requires a sewer line extension of more than 500 feet to reach the project, a registered professional engineer must design and stamp the line extension. The cover sheet shall include the Owners/Developer's name, address, telephone number, and fax number, plus the design professional's name, address, telephone number, and fax number. The cover sheet shall also include the funding source if state or federally funded, and a detailed project location map. The cover sheet shall also show the numbers of the tax map and parcel in bold letters.

The plans shall be clear and legible. They shall be drawn to a scale which will permit all necessary information to be plainly shown. Plans shall be submitted on 22" x 34" drawing sheets and shall be submitted concurrently in an "Autocad" drawing electronic format. A sheet index shall be provided, as well as a legend of symbols used. Horizontal locations shall be referenced to Georgia State Plane Coordinates (West Zone feet). Vertical locations shall be shown referenced to Mean Sea Level. Reference all horizontal locations to the NAD83/94 (latest adjustment) datum and reference all vertical locations to the NAVD88 datum. All orthometric locations shall be referenced to Geoid 99/03. All points are subject to verification by the Cherokee County Water & Sewerage Authority. Sewer line locations shall be shown on plans and submitted in ASCII Text or EXCEL electronic format for each point. The Developer shall provide ASCII or EXCEL spread sheet files for coordinate data. (comma delimited). Each Point



I.D. (M.H., Force Main, etc...) shall be show at the correct location on the printed plans.

The information submitted electronically for gravity sewer lines shall include:

- a.) Manhole ID (CCWSA staff will assign manhole ID number during plan review. The manhole ID numbers shall be shown on the revised construction plans submitted for final review before the plans are stamped. (See Section 102.7) The same ID numbers shall be used for As-Builts. (See Section 604.)
- b.) Northing
- c.) Easting
- d.) Center of Manhole (Lid) Elevation
- e.) Invert (In and Out) Elevations
- f.) Each Manhole point shall include pipe(s) entering and leaving manhole. Pipe(s) size, Pipe Invert, Material, Type (i.e. Sewer line, service line or force main).

Force Mains along County or State Roads and cross country shall be located at 50' intervals (ground and top of pipe). If Force Main is within the development and maintains a constant distance behind curb and constant depth, locate at all transitions (vertical and horizontal). All fittings, tees and bends, valves, and air release valves shall also be located. All vertical locations shall be finished ground and top of pipe. The Contractor shall place a vertical piece of 2" diameter P.V.C. pipe on top of the pipe at all bends, tees, fittings, valves, elevation transitions, horizontal transitions and every 50' along the length of the force main (County or State Roads and cross country) for the purpose of enabling the surveyor/engineer to locate the force main for "As-Builts". The Contractor will then be responsible for removing the vertical P.V.C. sections after the as-built locations have been verified by the Authority. The rim elevation, top of pipe and the manhole invert elevation of all air release valve manholes shall be located. The size and material of all pipes shall be recorded.

**Force Main Pipe Lines, Fittings etc.**

- a.) Point ID (see CCWSA staff)
- b.) Northing
- c.) Easting
- d.) Ground Elevation
- e.) Top of Pipe Elevation
- f.) Point Description/Fitting Type and Pipe Size

### **Air Release Valves (Manholes)**

- a.) Manhole ID (C.C.W.S.A. staff will assign manhole I.D. number during plan review. The manhole I.D. numbers shall be shown on the revised construction plans submitted for final review before the plans are stamped. The same I.D. numbers shall be used for "As-Builts").
- b.) Northing
- c.) Easting
- d.) Center of Manhole (Lid) Elevation
- e.) Invert Elevation
- f.) Top of Pipe Elevation
- g.) Each Air Release Valve Manhole point shall include Pipe Size and Material.

Plans for sanitary sewers shall include a site plan, plan and profile sheets, the General Notes for Sanitary Sewer System Construction, sections and supplementary views, erosion and sediment control plan, and detailed design drawings for all special fixtures.

## **1. SITE PLAN**

The site plan shall show land lots, district, north arrow, lot layout and existing and proposed building locations. Lot numbers shall run in consecutive order and there shall be no duplicate lot numbers within the project. The site plan shall also show all existing and proposed streets and their names, all streams, water courses, storm drains and the discharge points for all drainage structures. The site plan shall show the topography with contour lines at suitable intervals. On the site plan, show the sewer layout with existing and proposed lines, manhole numbers, line designation and direction of flow. Also, show the size of all lines and the location of proposed services.

The design of cross-country sewer lines and force mains shall be based on field-run surveys. The site plan for cross-country sewer lines and force mains need not show contour intervals, but the profiles shall be based on mean sea level elevation. Site plans for lift stations shall show existing and proposed contours.

In the event the subdivision is developed in phases, the final construction plans for sewers may be submitted in phases or units. However, at the time the first phase is submitted, the engineer will submit one copy of the preliminary layout of the entire sewer system. This layout will show all lines required to serve any lots to be developed and any surrounding property that may be served through the property. The site plans for each phase or unit shall contain a location drawing showing the relationship of the phase or unit to the total project and to the surrounding streets and sewer outfalls.

## **2. PLAN AND PROFILE SHEETS**

Profiles should have a horizontal scale of not more than 100 feet to the inch for cross-country lines and 50 feet to the inch for congested areas, and a vertical scale of not more than 10 feet to the inch. The plan view should be drawn to a corresponding horizontal scale. The plan view should normally be shown on the same sheet as the profile. In any case both the plan and profile view should have line designations, station numbers, manhole numbers and any other indexing necessary to easily correlate the plan and profile view. Both the construction plans and the "As-Built" plans shall show station numbers along the alignment of the sewer main plus call out the specific stations of all features such as manholes, laterals, etc. along with the Point I.D. Match lines shall be provided where necessary.

Plans and profiles shall show:

- a.) Location of streets, sanitary sewers and drainage easements.
- b.) Profile of ground surface, the grade of the sewer between each two adjacent manholes, size and material of pipe, length between manholes, invert of sewer in and out of each manhole, and surface elevation at each manhole. All manholes shall be numbered (CCWSA I.D. Number.) on the plans and correspondingly numbered on the profile and electronic data. Station numbers will be shown for each manhole. The profile of adjacent parallel stream beds and of adjacent lake surfaces, low buildings, and low lots shall be shown on the profile. When a body of water is located adjacent to a project, indicate the 100 year flood zone elevation of the stream/river and/or the high water/winter pool elevations of lakes or reservoirs.
- c.) Locations of all special features such as connections to existing sewers, concrete encasements, collar walls, ductile iron pipe sections, elevated sewers, piers, special manhole covers such as vented outfall covers or sealed covers, etc.
- d.) All known existing structures both above and below ground which might interfere with the proposed construction, particularly water mains, gas mains, storm drains, utility conduits, retaining wall footings, etc.
- e.) Bench marks and control points shall be shown on the plan and profile sheets. Horizontal and vertical coordinate data shall be provided on the plans for each bench mark and control point. The vertical datum used shall be the elevation above mean sea level.

## 203. PLAN REVIEW PROCESS

**Plan Review Schedule:** The Authority and reviewing engineer shall meet every Tuesday with Developers or their representatives to discuss plan review comments and to distribute new sets of plans to the various Authority departments for review. Plans must be delivered to the Authority's G.P.S. Department by 4:30 p.m. on Monday to be distributed for review at the Tuesday meeting. Comments shall be made available to the Developer at the following Tuesday meeting one week after the plans are distributed. Comments on lift stations will require a minimum of two weeks. **Plans shall not be distributed for review until all required documents and electronic data have been submitted and all review fees have been paid.**

A list of comments noting any deficiencies of the plans will be returned to the Developer or representative at the Tuesday meeting. The Authority's G.P.S. Department staff will assign manhole I.D. numbers during this phase of the plan review. These manhole I.D. numbers shall be shown on the plans to be re-submitted along with the other revisions.

After the revisions have been made, the Developer must submit six (6) revised copies of construction plans plus the electronic data on disc, as outlined in these specifications to the Authority for review.

If all of the required revisions have been properly made, the Authority will deliver a comment list stating "No Exceptions" to the Developer or their representatives, thereby allowing the Developer to return to the Authority's G.P.S. Department to have the plans stamped "Approved". The Developer can have as many sets stamped "Approved" as he or she may need for construction, but the Developer shall submit a minimum of four (4) new sets of plans to the Authority for stamping and retention by the Authority for use during construction. Plus the electronic data on disc, as outlined in these specifications.

The Developer shall complete the Ownership Form (Exhibit "A") and submit it to the Authority's G.P.S. Department before the Authority's Construction Permit is issued to the Developer.

The Developer shall forward a copy of all county and state permits to the Authority's G.P.S. Department before the Authority's Construction Permit is issued to the Developer.

The Developer shall arrange for the preconstruction meeting with the Chief Inspector.

When the project is completed, the Developer shall forward two copies of the recorded final plat and the "As-Builts" to the Authority's G.P.S. Department before any water meters are released to the project.

## **SUBMITTAL OF REVISED PLANS**

All construction plans submitted for review of revisions requested by the Authority must list each revised item with a cloud around the revised area on the plan sheet and must identify which reviewing authority requested the revision.

## **PROTECTION OF UTILITIES**

Each plan sheet should include a note stating "The Contractor must call the Utilities Protection Center "Call Before You Dig" telephone number (1-800-282-7411) four days before starting any excavation. Each set of plans shall include a reproduction of the following information (Detail S738) from the Utilities Protection Center:

**DETAIL S738**

**COLOR CODES  
FOR  
UTILITY LOCATING**

<b>RED</b>	<b>ELECTRIC</b>
<b>YELLOW</b>	<b>GAS-OIL</b>
<b>ORANGE</b>	<b>TELEPHONE/CATV</b>
<b>BLUE</b>	<b>WATER</b>
<b>GREEN</b>	<b>SEWER</b>

**IF YOU DIG GEORGIA**

**CALL US FIRST !**

1-800-282-7411

*It's The Law !*

**Utilities Protection Center, Inc.**

**THREE WORKING DAYS  
BEFORE  
YOU DIG GEORGIA  
CALL**

**Utilities Protection  
Center, Inc.**



**1-800-282-7411**

*It's The Law !*

## DETAIL S739 – PAGE 1 of 4

### CHEROKEE COUNTY WATER AND SEWERAGE AUTHORITY SANITARY SEWER SYSTEM CONSTRUCTION GENERAL NOTES

1. All sanitary sewer system construction must follow the current Cherokee County Water and Sewerage Authority Sanitary Sewer System Standards.
2. For D.I.P. sewer lines, the minimum wall thickness shall be Class 50 and the interior lining shall be Protecto 401 ceramic epoxy. Wall thicknesses greater than the minimum called for above may be required due to greater depths or varying bedding requirements. Class C bedding is the minimum allowed.
3. All Polyvinyl Chloride (PVC) sewers 6" to 15" in diameter shall meet the requirements for minimum wall thickness as specified under SDR 35 in ASTM D3034, latest revision. PVC sewers that are 18" and larger in diameter shall have a minimum wall thickness as specified under T-1 in ASTM F679, latest revision. PVC sewers with more than 12' of cover may require wall thicknesses greater than SDR 35 or T-1. PVC is not allowed for sewers greater than 24" in diameter or more than 16' of cover.
4. Ductile Iron Pipe is required for sanitary sewer lines:
  - a. Crossing storm sewers or other utilities with less than 2' of clearance
  - b. Crossing water mains
  - c. Crossing all streams and vegetative buffers
  - d. For all cross country locations with less than 3' of cover
  - e. For all locations in roadways with less than 5' of cover
  - f. For all locations with 16' or more of cover
  - g. With 20% or greater slope
  - h. Inside all casings
  - i. Installed in subdivision easements between lots
  - j. Adjacent to all drop manholes (1 joint minimum at connection to drop manhole)
  - k. For all installations in fill material
  - l. At all other locations designated by the CCWSA
5. Information regarding underground utilities on these plans is not guaranteed as to accuracy or completeness. Prior to beginning work, the Contractor shall request a field location through the utilities protection center and any utility owners thought to have facilities in the area. The Contractor shall promptly compare these field-marked locations with the project plans and then notify the designer of any anticipated problems or need for design changes. It is the Contractor's responsibility to excavate or cause the utility owner to excavate for the purpose of determining exact elevations or locations at utility crossings and other critical locations well in advance of the work under this contract. Damage to existing utilities resulting from the Contractor's negligence shall be repaired at the Contractor's expense. The Developer and/or the Developer's Contractor is responsible for verifying the exact location, size, and material of any existing water or sanitary sewer facility proposed for connection or use by this project.
6. All sewer service laterals shall have a minimum diameter of 6" and a minimum grade of 1%.
7. The Developer shall obtain a land disturbance permit from Cherokee County governing all items related to erosion control.

## DETAIL S739 – PAGE 2 of 4

8. This project is located in Land Lots \_\_\_\_\_, in the \_\_\_\_\_ District of Cherokee County, Georgia.
9. Clearing will be kept to an absolute minimum. Vegetation and mulch will be applied to applicable areas immediately after grading is complete. Land disturbing will be scheduled to limit exposure of bare soils to erosive elements.
10. Construction activities will be performed in compliance with all applicable laws and regulations.
11. All marketable timber will be salvaged. Top soil will be salvaged, stock piled and spread on areas to be vegetated. Trees outside of the clearing line will be protected from damage by appropriate markings.
12. Contractor is responsible for staking the alignment of the proposed pipeline prior to pipe installation. If a conflict should arise, the contractor shall notify the designer at that time.
13. All excavated dirt shall be placed on the high side of the trench away from any creeks.
14. Any fill dirt over the pipe shall be graded to prevent ponding.
15. The right-of-way or construction easement represents the limits of clearing for the complete job. The contractor shall not clear beyond this limit.
16. A copy of the approved construction plans must be kept on the job site at all times that construction is underway.
17. No bury pits are allowed.
18. Topographic ground elevations along all sewer lines, gravity and force mains, are from field-run surveys, not aerial photographs.
19. All easements must be acquired prior to the preconstruction meeting with the Chief Inspector.
20. The Developer/Contractor shall meet with the Chief Inspector at least 24 hours before beginning construction. The Contractor shall notify the Chief Inspector or his designated representative by 8:30 a.m. of each workday when work is scheduled unless authorized otherwise.
21. Sanitary sewer force mains shall be installed so that the top of the pipe is a minimum of four feet below final grade, four feet below the edge of the pavement, or four feet below the ditch paralleling the road, whichever is deepest.
22. Type 4 bedding is required at all restrained pipe installations.
23. Contractor must show proof of insurance in the amount specified by the CCWSA.
24. A horizontal separation of at least 10 feet is required between existing or proposed water mains and existing or proposed sanitary sewer lines.
25. A vertical separation of at least 18 inches is required where a sewer line crosses an existing or proposed water main. A full joint of sanitary sewer pipe is required to be centered at the water main crossing.



### **DETAIL S739 – PAGE 3 of 4**

26. No portion of this project is being constructed on or near an existing landfill, abandoned landfill, or any other site used for waste disposal.
27. Potable water and sanitary sewer structures are not allowed within a dam. Utility pipelines and structures must be a minimum of 30 feet outside the toe of slope of the dam.
28. Existing County roads shall not be open cut unless permission is granted by the Cherokee County Department of Public Transportation.
29. Plan approval is valid for 12 months without beginning construction. Plans shall be subject to beginning the process of review and approval if 12 months expire prior to the start of construction.
30. Record drawings of water and sanitary sewer facilities are required to be submitted to the CCWSA upon completion of the project.
31. If construction plans are stamped for a full project, and then the Developer revises the plans to build the development in phases, no construction or field inspection will be allowed to begin until the revised, phased plans are re-approved and stamped for the phased construction.
32. All streams and protective buffers shall be crossed in accordance with current County and State regulations.
33. Inside of steel casings, pipe joints shall be restrained using Fast-Grip gaskets or approved equal.
34. Safety platforms are required for all manholes that are 16' in depth or more.
35. Concrete footings are required for all manholes that are 16' in depth or more and for all manholes installed in fill material.
36. Sanitary sewers in roadways shall be installed with a minimum of 7' of cover where laterals are located in order to obtain a minimum cover of 5' over the lateral at the R/W limit, or DIP laterals are required.
37. The CCWSA shall not be responsible for any building built too low to be served by the sanitary sewer system.
38. The CCWSA shall not be responsible for any sanitary sewer services covered or buried by construction.
39. Soil adjacent to all manholes located in roadways will be tested for 95% compaction. The CCWSA must receive a copy of the results of the testing before the final plat will be signed.
40. When transitioning from DIP to PVC, the Contractor must utilize solid sleeves or "Harco" fittings.
41. All angles between "in" lines and "out" lines for manholes shall be labeled. Acute angles (angles < 90 degrees) are not allowed for sewer mains or sewer services.
42. Sewer lines that have slopes greater than 20% shall be DIP and shall be provided with concrete anchors (Detail S716).

43. Manholes located in future streets must be installed to be 48" or higher above grade.

**DETAIL S739 – PAGE 4 of 4**

44. Manholes that are located outside of roadways shall be installed to be at least 18" above grade and shall be provided with self-sealing, bolt-down covers.

45. For any new project connecting to an existing manhole, the Contractor shall core and boot the existing manhole at an elevation that is 2 feet or less from the existing invert out.

46. Inside drop manholes shall be 5 feet in diameter and shall be built in accordance with Detail S703.

47. All force mains paralleling water mains shall be encased in green polyethylene tubing so as to identify the force main as sanitary sewer.

48. Inside of developments with curb and gutter, the Contractor shall cut a "S" into the top of the curb above all sanitary sewer service laterals.

49. Locator wire must be installed above all sewer lateral lines.

50. Sanitary sewer cleanouts shall be installed for all service laterals at the edge of the sewer easement. CCWSA maintenance of laterals ends at the sewer cleanout.

## **204. EROSION AND SEDIMENTATION CONTROL PLAN**

- 1.) The provisions of the Erosion and Sedimentation Act of 1975 (O.C.G.A. 12-7-1 et seq.), as amended, shall govern all land disturbing activities as relates to construction performed. The Cherokee County Water & Sewerage Authority is not delegated enforcement powers for enforcing the provisions of the Erosion and Sediment Control Act of 1975.
- 2.) The Georgia Soil and Water Conservation Commission has taken provisions of ACT 599 and published a **MANUAL FOR EROSION AND SEDIMENT CONTROL IN GEORGIA**, 2000 Edition (or any more current edition as they are published). Sewer construction plans and specifications shall include appropriate segments of this manual. Developers, Engineers, Design Professionals and Contractors performing work in Cherokee County are responsible for acquiring a copy and using the best practical methods contained therein to control the erosion and sedimentation of the construction site in conformance with the intent of ACT 599. Copies may be purchased from the Georgia Soil And Water Conservation Commission, P.O. Box 8024, Athens, Georgia 30603. For additional information, call the Commission at 706-542-3065.
- 3.) The erosion control plan must be approved by Cherokee County Engineering and the Natural Resource Conservation Service (NRCS). The approval of the plan included in the NRCS Report of Technical Review must be attached to the initial submittal of construction plans.

## **205. DETAIL DRAWINGS**

Special detail drawings made to a scale to clearly show the nature of the design shall be furnished to show the following particulars:

- a.) All stream crossings and storm drain outlets with elevations of the stream bed and of normal and extreme high and low water levels.
- b.) Details of special sewer joints and cross sections.
- c.) Details of special sewer appurtenances such as standard manholes, drop manholes, service connections, manhole frames and covers, manhole steps, air relief valves and thrust blocking for force mains, elevated sewers, piers, pipe bedding, special highway crossings, railroad crossings, etc.

## **206. PLAN APPROVAL**

- a.) All projects requiring a lift station shall be reviewed and approved by the Sewer Coordinator and Pumping System Manager. All projects that serve, or has the potential to serve, a business that is required to have a grease trap or dumpster pad shall be reviewed and approved by the Pretreatment Coordinator.
- b.) The following sanitary sewer projects shall be reviewed and approved by both the Cherokee County Water And Sewerage Authority and the Georgia EPD:
  - 1.) Land Application Systems.
  - 2.) Water Pollution Control Plants.
  - 3.) Sewers greater than 36 inches in diameter.
  - 4.) Pumping stations with a capacity of 700 GPM or more.
- c.) No work shall begin until plan approval is received from the Authority and a Construction Permit is issued by the Authority. The CCWSA General Manager or authorized representative of the CCWSA shall have final approval of the preliminary plans, construction plans and final plans. If a discrepancy occurs between the approved plans and the Sanitary Sewer Main Standards, the Standards shall be the superseding document. The General Manager of the Cherokee County Water and Sewerage Authority or his designated representative may modify or cause to be modified any plans that he believes are in the best interest and future integrity of the Authority.

## **207. REVISIONS TO APPROVED PLANS**

When any deviations from approved plans are proposed, the Chief Inspector shall be notified for authorization. Revised plans should be submitted as soon as possible to the Chief Inspector. Minor changes not affecting the sewer system operation may be allowed in the field during construction by the Chief Inspector. The Chief Inspector shall have authority as to what constitutes a minor or major change. "As-Built" drawings and the required electronic data on disc shall be furnished to the Authority at the completion of construction.

Any section or unit must be built in accordance with the plans. If the Developer decides to phase a section off, a new set of plans showing the phase change will have to be resubmitted and approved.

## **208. APPROVAL BY OTHER GOVERNMENT AGENCIES**

No part of the plan approval process is intended to relieve the Developer of the responsibility to comply with the minimum standards of the Georgia Department of Natural Resources, EPA, EPD, NRCS, Georgia D.O.T., Cherokee County Engineering

Department, U.S. Army Corps of Engineers or other appropriate regulatory agency.

Generally speaking, the following documents should be provided to the Authority with the plans, and should also be sent to the proper agency claiming jurisdiction:

- A.) An approved Erosion and Sedimentation Control Plan (Note, a Land Disturbing Activity Permit and a Grading Permit must be acquired by the Developer prior to beginning construction). Include with this plan the Natural Resource Conservation Service Report of Technical Review approving the erosion control measures.
- B.) A letter stating that none of the sewers, services, or other utilities associated with the project are constructed on or proposed to be constructed on a solid waste landfill, according to the records of the County Roads and Bridges Department.
- C.) A copy of the Comprehensive Monitoring Plan that complies with the EPD's NPDES Storm Water Monitoring Permit regarding storm water discharge.

The submittals listed above are not intended to be an all-inclusive list of submittals needed to adhere to all of the government agencies having jurisdiction over construction on a project. It is up to the Developer to inform himself and adhere to the development regulations of the respective governing agencies.

## **209. RELOCATION OF EXISTING WATER AND SEWER FACILITIES**

All existing sewer facilities that have to be relocated, as might occur at roadway entrances, easements, elevation changes, etc., will be relocated by the Developer's Contractor at the Developer's expense. The Authority will inspect all such work prior to acceptance.

## **210. EASEMENT ACQUISITION AND UTILITY ENCROACHMENT PERMITS**

- A.) It shall be the responsibility of the Developer to obtain any off-site easements required to connect the project to existing public sewers. Easements will be conveyed to the Cherokee County Water and Sewerage Authority for all facilities which are to be conveyed to the Authority. This process must be started early enough to allow construction of the sanitary sewer mains before any building construction is to begin. No building permits, water meter or sewer tap applications shall be issued until off-site water mains and sewers have been constructed and accepted. This condition shall override any provision for speed up of house starts such as furnishing a bond to guarantee completion of the streets and other appurtenances. A sample sanitary sewer main easement agreement is included at the end of Section 200.

- B.)** All easements shall allow adequate room to construct the sewer and appurtenances. Permanent easements shall be a minimum of 20 feet wide, and construction easements shall typically be a minimum of 60 feet wide. Wider easements shall be required where water and sewer lines are deeper than normal or where a trunk or interceptor sewer line greater than 15 inches is expected to pass through the development. The maximum cross-slope of the permanent easement shall be 10%. The Authority reserves the right to require larger permanent easements where deemed necessary.
- C.)** Easement drawings shall be prepared for work outside the development prior to approval of the sewer plans. The drawings shall be of a size suitable for legal recording and shall be prepared by a Registered Land Surveyor. The drawing must be clear and legible for printing. The drawing shall be at a reasonable scale and shall not be a reduced copy of the plan sheet. The drawing will show property lines, the name of property owners with the length of line encroaching on each property owner, size of line, line designation, manhole numbers and stations, width of permanent and construction easement, scale of drawing, north arrow, land lot and district numbers, and a tie to the nearest land lot corner. Any streets or other existing easements shall also be shown. Easement agreements referencing these drawings shall be prepared and attached to the drawings, signed by the property owners, and recorded at the Cherokee County Clerk of Superior Court's office. A copy of the recorded easement agreement shall be provided to the Authority before the Authority's Construction Permit is issued to the Developer.

**Return to:**  
Cherokee County Water & Sewerage Authority  
1957 Authority Drive  
Woodstock, Georgia 30189  
Attn: Jeffery Hooper  
**State of Georgia**  
**County of Cherokee**

**Grant of Easement**  
**Sewer Line/Main**

This grant of easement made this \_\_\_\_\_ day of \_\_\_\_\_, 20\_\_\_\_\_, from \_\_\_\_\_ of the State of Georgia, and County aforesaid, hereinafter called Grantor, to **CHEROKEE COUTY WATER AND SEWERAGE AUTHORITY**, a Political Subdivision of the State of Georgia, herein called the Grantee.

**WITNESSETH**, the Grantor for and in consideration of the sum of \$1.00 and other valuable considerations in hand paid, at and before the sealing and delivery of these presents, does grant bargain, sell, and convey unto Grantee an easement and perpetual right-of-way over, upon, through, under and/or across the property of the Grantor in Land Lot \_\_\_\_\_, of \_\_\_\_\_ District, 2<sup>nd</sup> Section, Cherokee County, Georgia, and being a strip of land more particularly described and shown on the plat attached hereto as Exhibit "A" and entitled \_\_\_\_\_ (Subdivision Name, Phase, Unit, and or Pod, \_\_\_\_\_ Lot Number \_\_\_\_\_) made a part hereof showing the dimensions and location of this easement. The permanent easement covered by this instrument is \_\_\_\_\_ feet wide, with the permission to use an additional \_\_\_\_\_ feet wide during construction. The easement begins and ends where the said pipeline enters and leaves the property line as indicated above, and totals approximately \_\_\_\_\_ feet in length.

The easement covered by this instrument is for the purpose of a sanitary sewer line/main and utility installation together with the right to go upon said land to install said water line and installations with the continuous right from time to time to go in and upon said right of way and to construct, install, operate, maintain, inspect, reconstruct, repair, renew, and replace therein the pipeline and other installations as may be necessary; also the right to clear, keep clear, remove and dispose of all undergrowth, trees and other obstructions, objects and structures on said right of way, which are inconsistent with the rights of the Grantee and which may interfere with or endanger the construction, operation and maintenance of said sewer line/main and other installations; also the right of ingress and egress to and from said right of way over roads, if any, existing at the time for such ingress and egress, for the purpose of constructing, operating, maintaining, repairing, renewing, replacing said sewer line/main and installations. Said right of way easement may be used by the owners of said land, or their assigns, provided such use is not inconsistent with the rights sought to be condemned and further that such use does not interfere with, injure or endanger said sewer line/main and other installations and the construction, repairing, renewal and replacement thereof and the uses for the purposes hereinbefore stated.

The Grantor does hereby covenant that they are lawfully seized and possessed of the real estate above described, that Grantor does have good and lawful right to convey the said property, and said property is free from all encumbrances, and that they will forever warrant and defend title thereto against the lawful claims of all persons whomsoever.

IN WITNESS WHEREOF, said GRANTOR hereunder set his hand and affixed his seal on the date written above.

**WITNESS**

**GRANTOR(S)**

\_\_\_\_\_  
Witness (printed name)

\_\_\_\_\_  
Grantor (printed name)

\_\_\_\_\_  
Witness (Signature)

\_\_\_\_\_  
Grantor (Signature)

\_\_\_\_\_  
Grantor (Printed Name)

\_\_\_\_\_  
Grantor (Signature)

**CCWSA ACCEPTANCE**

Sworn to and subscribed before me  
this the \_\_\_ day of \_\_\_\_\_ 20 \_\_\_\_.

\_\_\_\_\_  
CCWSA Representative (Printed Name)

\_\_\_\_\_  
Notary Public (SEAL)

\_\_\_\_\_  
CCWSA Representative (Signature)

## **SECTION 300 - DESIGN CRITERIA**

### **301. GENERAL**

The criteria listed herein is not intended to cover all aspects of design, but rather to mention the basic guidelines and those particulars that are required by the Cherokee County Water and Sewerage Authority.

### **302. TYPES OF SEWERS AND LINE EXTENSION REQUIREMENTS**

Sewers shall be designed as separate sanitary sewers only in which rainwater from roofs, streets, and other areas and groundwater from foundation drains are excluded. Overflows from sewers shall not be permitted.

- A.)** All specifications required by the Authority and by the Georgia Department of Natural Resources must be met by the Developer.
- B.)** If an existing sanitary sewer main must be extended to serve a particular development, the Developer will be required to pay all of the initial costs, including but not limited to construction costs, testing fees, engineering fees, etc.
- C.)** In certain circumstances, the Authority may require a larger pipe size to be installed than is required by these standards, and the cost of this oversizing may be funded by the Authority. The Developer may be required to pay all of the initial costs. If the purpose of the oversizing is due to the Authority's master plan for sewage collection within the County, the Authority may enter into negotiations with the Developer to provide funding for the betterment.

### **303. DESIGN PERIOD**

Sewer systems should be designed for the estimated ultimate tributary population. Tributary population is considered to be all areas upstream of the discharge point of the system being designed. Consideration should be given to the maximum anticipated capacity of institutions, industrial parks, etc.



### **304. DESIGN FACTORS**

Sewers will be designed and installed from the existing Authority sewer system to the uppermost property line of the development being served. In determining the required capacities of sanitary sewers, the following factors should be considered:

- A.)** Maximum hourly sewage flow.
- B.)** Additional maximum sewage or waste flow from industrial plants.
- C.)** Ground water infiltration.
- D.)** Topography of the area.
- E.)** Depth of excavation.

New sewer systems shall be designed on the basis of an average daily flow of sewage of not less than 400 gallons per household per day. Sewers should be designed to carry the per capita flow when flowing one-half full. Normally, all sewers shall be designed with a peaking factor of not less than 3.6 and this may be increased upon the direction of the reviewing engineer. When deviation from the foregoing per capita rates is demonstrated, a description of the procedure used for design shall be included.

The Authority has the option of granting a variance from the requirement for the Developer to install sanitary sewers within the development to the uppermost property line of the development if this creates an undue hardship on the Developer. If this variance is granted, the Developer will be required to grant and record a 60 foot wide construction easement and a 20 foot wide permanent easement dedicated to the Cherokee County Water & Sewerage Authority for future use. The sanitary sewer line must be designed to the uppermost property line of the development so that the easements will be set in the proper location to build the sewer line. The construction easements will remain in effect until such time as the sanitary sewer lines are constructed and accepted by the Authority. The Cherokee County Water & Sewerage Authority may at its option require additional easements.

Minimum easement widths to be dedicated are 20 feet for permanent easements and 60 feet for construction easements, with both the permanent and the construction easements typically centered on the sewer main. The easements may need to be offset if paralleling a vegetative buffer adjacent to a creek. Also, in the event that a trunk or interceptor sewer line greater than 15 inches or of great depth is expected to pass through the development, the construction easement width shall be increased to the amount required for construction of the expected sewer. All easements are to be checked in the field and must be adequate for the purpose for which they are dedicated. Also, consideration must be given for expected building locations and the easement shall be located for the least possibility of conflict before the sewer may be constructed.

No structures shall be built on dedicated easements and the Authority will not be responsible for the removal of fences that are placed on dedicated easements in the event the sewer is constructed. Septic tanks in these types of developments shall be placed in a location to facilitate the connection of the sewer service to the sewer main.

## **305. DETAILS OF DESIGN AND CONSTRUCTION**

### **A.) Size**

No sanitary sewer main shall be less than 8" after leaving the uppermost property line to be served. Trunk mains shall be a minimum of 10" in diameter.

Where the need for sizes of pipe differ between manholes (such as 15" PVC and 16" DIP), the Developer shall install the one size of DIP for the entire section of line between the manholes. Transition sleeves are not allowed.

### **B.) Depth**

Any sewers installed in the street shall be sufficiently deep to provide 5 feet of cover at the inlet end of all service laterals at the street right-of-way, and over any part of the main or service within the street right-of-way.

Any sewers on off-street easements shall have a minimum of four feet of cover unless ductile iron pipe is used. Filling over the pipe to obtain minimum cover is not allowed if the fill will impede the natural flow of surface water or will cause an erosion problem.

Sanitary sewers paralleling creeks or ditches shall be designed to make the top of the sewer line at least two feet below the bottom of the creek or ditch adjacent to the sewer throughout the site to be developed.

### **C.) Ditch and Creek Crossings**

Aerial sewers are not allowed. The required method of crossing a river, stream, creek, impoundments, or wet weather ditch is with a bore under the creek or river with a minimum of three feet (3') of cover between the lowest point in the stream and the top of outside diameter of the casing.

#### **D.) Polyethylene Encasement**

Ductile iron pipe shall be provided with polyethylene encasement whenever the sewer main either crosses or is in close proximity to a steel gas main. Ductile iron pipe installed in low-lying damp areas and in areas where anode beds are known to exist shall also be provided with polyethylene encasement. The length of the encasement of DIP gravity sewers shall be in accordance with DIPRA recommendations. The reviewing engineer and the Authority shall have final authority over the required length of the encasement during the plan review process. The entire length of DIP force mains shall be encased in green polyethelene tubing.

#### **E.) Dams**

Gravity sewer lines may be placed at the toe of the slope of the dam, but not in the slope. Pressurized force mains and water mains shall not be closer than 20 feet to the toe of a dam.

### **306. GRAVITY SEWER PIPE**

All gravity sanitary sewer pipe up through 24-inch diameter must be Polyvinyl Chloride (PVC), Vitrified Clay Pipe (VCP), Ductile Iron Pipe (DIP), or Steel Pipe, except where D.I.P. or Steel Pipe is required. For pipe larger than 24-inches in diameter, the Contractor may have the option of using either Polyvinyl Chloride (PVC), Reinforced Concrete Pipe (R.C.P.), Ductile Iron Pipe or Steel Pipe, except where Ductile Iron Pipe (DIP) or Steel Pipe is specifically shown on the plans. High Density Polyethylene (HDPE) pipe is allowable for gravity installations only in trenchless technology applications. All pipe shall be installed with a minimum of Class "C" bedding.

### 307. SLOPE

All sewers shall be so designed and constructed to give mean velocities, when flowing one-half full, of more than 2.0 feet per second based on Kutter's formula using an "N" value of 0.013. The following are the minimum slopes which shall be provided; However, slopes greater than these are desirable:

<u>Sewer Size</u>	<u>Minimum Slope in Feet Per 100 Feet</u>
8"	0.50
10"	0.40
12"	0.30
15"	0.20
16"	0.20
18"	0.18
21"	0.14
24"	0.10
27"	0.10
30"	0.10
36"	0.10

These minimum slopes shall be used only when sufficient flows are expected to maintain a velocity of more than 2.0 feet per second and maintain a cleansing action in the line. Sewers shall be laid with uniform slope between manholes. Sewers on 20 percent slope or greater shall be ductile iron pipe and shall be anchored securely with concrete anchors (See Standard Details) to prevent displacement by erosion or shock. Maximum slope of sewers shall be 30 percent and sewers shall be designed at less than 20 percent whenever possible.

### 308. INCREASING SIZE

When a certain size sewer is connected to a larger one at a manhole, the connection shall not be lower than matching the 0.8 depth point of both sewers to the same elevation. For example, when connecting an 8 inch pipe to a 60 inch pipe, a point 6.4 inches above the invert of the 8 inch pipe shall not be lower than a point 48 inches above the invert of the 60 inch pipe. Match crowns of the two pipes whenever possible.

### **309. SEWER LINES THROUGH GOLF COURSES**

Where sewer lines are installed through existing or proposed golf courses, the pipe size shall be oversized as determined by the Authority. The Developer may be required to install parallel sewer lines if growth patterns indicate an increase in sewage generation upstream of the golf course. This applies to gravity mains and force mains and is subject to the discretion of the Authority.

### **310. SANITARY SEWER FORCE MAINS**

- A.)** Force mains 4 inches in diameter or larger shall be ductile iron pipe and shall conform to section 402.A of these Standards. Ductile iron force mains shall be encased in green polyethylene tubing.
- B.)** Force mains smaller than 4 inches in diameter shall be CertainTeed, Eslon, Dyka, Vulcan, or alternate acceptable to the Authority, Class 200 SDR 21 integral bell PVC pressure pipe. HDPE pipe is also allowable for these smaller force mains.
- C.)** See Standard Details for the minimum concrete blocking requirements. Design engineer shall be responsible for design of blocking where more than the minimum is required. For internal pressures in excess of 100 PSI, blocking calculations **MUST** be submitted to the Cherokee County Water & Sewerage Authority for review.
- D.)** The location of force mains inside subdivisions shall be 11' behind the back of the curb. The location of force mains outside of subdivisions shall be as allowed by Cherokee County and approved by the Authority. The preferred location of the force main is the side opposite the water main.
- E.)** Force mains shall be installed so that the top of the pipe is a minimum of four feet below final grade, four feet below the edge of the pavement, or four feet below the ditch paralleling the road, whichever is deepest. Permission must be granted by the Authority to vary from this requirement.
- F.)** All force mains shall enter the receiving manhole with 6" or larger diameter pipe. At a point 10 feet away from the manhole, the force main may reduce down to its normal pumping diameter.

### 311. MANHOLES

Manholes shall be installed at the end of each line; all changes in grade, size, or alignment; at all intersections; and at distances normally not greater than 350 feet. Spacing for 8 inch sewers can be more than 350 feet but not more than 400 feet and will be allowed only in isolated cases when, in the opinion of the reviewing engineer, it is impractical to install an additional manhole and when the extra distance will not impede maintenance of the line. Manhole spacing in sewers 10" and larger will conform to Ten State Standards. In no circumstance will a spacing of greater than 300 feet be allowed when the slope exceeds 10 percent. Cleanouts may be used only for special conditions and shall not be substituted for manholes nor installed at the ends of laterals greater than 150 feet in length. Manholes in cross-country areas shall be elevated so that the top is 18 inches above ground. Manholes installed in future streets for the next unit shall be elevated so that the top of the manhole is 48" above ground.

A maximum of four holes shall be cored into the base of a manhole for pipes. More holes may be cut into the manhole if the holes are staggered in elevation by 2 feet and are used for laterals going with the flow.

### 312. DROP MANHOLES

A drop pipe shall be provided for a sewer entering a manhole at an elevation of more than 2.0 feet above the manhole invert. The drop pipe shall be of ductile iron materials.

All outside 90° elbows shall have thrust block poured below the elbow. Drop Manhole will be noted on the construction plans at any time the drop exceeds 2.0 feet. Where the difference in elevation between the incoming sewer and the manhole invert is less than 2.0 feet, the invert shall be sloped to prevent solids deposition. **Inside drop manholes are required where the drop in elevation is 10 feet or more.** Inside drop manholes shall be a minimum of five feet in diameter for pipe less than 15" in diameter and six feet in diameter for pipe greater than or equal to 15" in diameter, and shall be constructed in accordance with the details in Section 900. The structure of the drop inside the manhole shall be located opposite of the manhole steps. Inside drop manholes are not allowed in manholes with safety platforms.

### 313. CONNECTIONS TO THE AUTHORITY'S SEWER SYSTEM

At the point of connection to the Authority's existing sanitary sewer system, the new sanitary sewer line shall remain plugged or otherwise disconnected from the system until the new sanitary sewer lines are inspected, tested and determined to be acceptable to the Authority's Chief Inspector. The Developer will be fined for any storm water flows, mud or other construction debris that enters the Authority's system due to non-compliance with this requirement.

### **314. CONNECTIONS TO EXISTING MANHOLES**

Connections to existing manholes shall be made by coring the existing manhole with a coring machine. "Knocking out" holes for connections shall not be allowed. The cores shall be made at an elevation of 2' or less above the invert of the manhole.

### **315. STEEL CASINGS**

Steel casing pipe shall be used for all cased piping where the carrier pipe is eight inches (8") or greater in size.

### **316. PROTECTION OF WATER SUPPLY AND OTHER UTILITIES**

**A.)** The Cherokee County Water and Sewerage Authority has an established Cross-Connection Program to prevent the entry of contaminants or pollutants into any area of the potable water supply through the control of cross connections. It is illegal to introduce any substance into or to have any cross connections with the potable water supply. There shall be no physical connection between a public or private potable water supply system and a sanitary sewer which would permit the passage of any sewage or polluted water into the potable water supply.

**B.)** A horizontal separation of at least 10 feet is required between water mains and existing or proposed sanitary sewer mains (measured edge to edge). Should conditions prevent a separation of 10 feet, the lines shall be laid in separate trenches.

When sewers cross under water mains, the sewer shall be laid so that the crown of the sewer shall be at least 18 inches below the invert of the water main. The two pipes shall be installed such that a full length of pipe will be centered over the crossing so that all joints will be separated as much as possible. Ductile iron pipe shall be installed for both mains when clearance is less than two feet.

In the rare circumstance when the 18 inches clearance between the water and sewer mains cannot be maintained, the DIP mains shall be installed as described in the paragraph above with the joints as far apart as possible, plus both mains shall be wrapped in polyethylene tubing and then encased in concrete for a distance of 10 feet on both sides of the crossing.

When sewers are laid within public streets, the manholes and sewer lines shall normally be laid along the centerline of the street at a depth of not less than 6 feet from the pavement surface to the top of the pipe. In curves and other areas where this is not possible, the lines and manholes are to be installed within the confines of the curb to avoid conflict with the curb and other utilities. Ductile iron pipe shall be used for sewer lines crossing storm sewers with less than a two foot clearance and at other times when directed by the Authority.

### **317. SEWER SERVICES**

A sewer service shall be provided for every existing or proposed lot or building. All services shall be shown on the construction and as-built drawings. A common service shall not be allowed for two or more buildings. The service shall extend to the property line of the lot being served and shall normally be within 10 feet of the lower corner of the lot. Each service shall terminate with a 6" PVC clean-out stubbed out of the ground and sealed with a temporary PVC cap as shown in standard detail S712.

The Developer shall be responsible for serving all lots developed. On any lot where the service cannot be found, the Developer shall be responsible for payment of the cost of installation of the service. Also, unless noted on the final plat, the service shall be low enough to serve the first floor elevation at building line. The Builder shall be responsible for the location of the service prior to the pouring of the foundation, driveway or other appurtenance. The Authority will not be responsible for any house built too low to be served nor for any service covered by construction.

No plumber or contractor will be allowed to connect to the sewerage system except to the end of the service provided for his connection. Also, any service provided will be utilized without the installation of additional services. The Builder will be responsible for replacing the temporary PVC cap with a sewer cleanout and installation of cast iron meter box flush with grade (meter box shall be traffic rated if located in driveway or sidewalk) as shown in standard detail S713.



### **318. GREASE TRAPS AND SAND/OIL TRAPS**

The Cherokee County Water and Sewerage Authority has developed and implemented a sewage pretreatment program to limit the amount of grease, sand and oil entering the sewer system from restaurants, service stations, feed mills, car wash operations and any other establishment where such devices are necessary for the proper handling of liquid wastes containing sand, grease, oil, flammable wastes or other harmful ingredients. The Developer is hereby required to meet with the Authority's Pretreatment Coordinator to determine the need for such a device. The Authority requires all such establishments to include a grease trap and/or a combination sand/oil trap as part of their sewage collection system, located between the business and the tap into the Authority's sewer line. The Standard Details include a typical design for these structures, but the size and dimensions of the trap and piping are dependent on the quantity of flow from the business. **The design engineer will be responsible for sizing the structure and the piping and submitting design calculations with the plans. The Authority will review the design and calculations for minimum requirements prior to approving the construction plans.** (Minimum Grease trap size shall be = 1500 gallons). Eating establishments/restaurants shall have a 1500 gallon grease trap for an occupancy of 75 seats or less. Eating establishments/restaurants shall have a two (2) 1500 gallon grease traps in series for an occupancy of 76 seats or more. The Authority shall determine the size(s) and the number of grease traps for establishments/restaurants with more than 150 seats or 150 person occupancy. All grease traps shall be installed according to the Authority's Typical Grease Trap Detail. The Authority will require that the traps be maintained and cleaned out on a regular basis at intervals determined by the Authority's policy. Sanitary sewage from the facility's toilets shall not route through the grease trap. Authority approval shall be required for any connection varying from this.

## **320. DUMPSTER PAD REQUIREMENTS**

- A.)** Dumpster pads shall be minimum of 5" thick reinforced concrete slabs on grade. The concrete for the pads shall be 4000 psi concrete reinforced with 6" x 6" welded wire fabric. The dumpster pad shall be placed on a sub-base of 12" of graded aggregate base. The pad shall be sloped to drain to the back of the pad at a rate of 1/4" per foot. Stop posts are to be placed in front of the pad drain so the dumpster or other objects will not block access to the drain. Dumpster pads shall have 6" concrete retaining curbs on three sides. Where required or desired, a concrete block concealment wall may substitute for the retaining wall.
- B.)** Dumpster pad drains for single or multiple dumpster installations shall be ZURN Model ZN 415 8" grate with solid hinged lid or alternate acceptable to the Authority. All drains shall have either a separate or a built in trap to prevent the escape of sewer gas.
- C.)** All drain piping shall have a minimum diameter of 4". Piping of 4" and greater under the slab or other paved areas shall be ductile iron pipe. Piping that is not under the slab or other paving and not greater than 36" in depth may be PVC. Clean-outs shall be installed at all changes in piping direction. Piping shall be sloped to drain by gravity. Minimum slope of 4" pipe is 2.5%.
- D.)** Dumpster pad drains shall be connected to and routed through a grease trap. Authority approval shall be required for any connection varying from this.

# SECTION 400 – LIFT STATION DESIGN CRITERIA

## 401. GENERAL LIFT STATION DESIGN SPECIFICATIONS

The following minimum requirements apply to wastewater lift stations:

**General:**

**The Cherokee County Water and Sewerage Authority reserves the right to make any changes in these requirements as may be deemed necessary.** The design of the lift station shall be based on the future build out of the drainage basin upstream of the station.

- 1.) Submittals to the Authority for lift stations shall include:
  - A.) TDH calculations.
  - B.) Pump curves from pump manufacturer.
  - C.) System curves.
  - D.) Cycle time calculations.
  - E.) Buoyancy calculations.
  - F.) Profile and aerial views of force main and pump station.
  - G.) Surge relief calculations showing whether surge control valves are necessary.
  - H.) The NRCS report of technical review for erosion and sediment control.
  - I.) Submittals shall be stamped by a professional engineer licensed to do work in the State of Georgia.

## 402. PUMP REQUIREMENTS

- 1.) Pumps that are acceptable are Flygt, Hydromatic, or alternate acceptable to the Authority, except that others for specific applications may be accepted on special approval by the Authority.
- 2.) Lift stations with pumps up to 25 HP shall be supplied with a spare complete pump at the request of the Authority. A spare total rebuild kit and spare impeller shall be required with all pump stations.
- 3.) All submersible pumps shall be provided with stainless steel chains connected to each pump to facilitate the removal of the pump from the wet well for maintenance.
- 4.) Pump operation shall be by pressure transducer and programmable controller with a 4-20MA output for SCADA. A spare pressure transducer and controller or a redundant level control system shall be supplied at the Authority's request.

- 5.) A pump operation and elevation schedule shall be provided on the design drawings. This schedule shall call for pump operation elevations, ground water elevations and minimum liquid level in the wet well. There shall be a minimum of five levels of control as follows:
  - a.) Low Level Alarm
  - b.) Pumps Off
  - c.) Lead Pump On
  - d.) Lag Pump On
  - e.) Lag-Lag Pump On (Triplex and Quadplex Only)
  - f.) Lag-Lag-Lag Pump On (Quadplex Only)
  - g.) High Level Alarm
  
- 6.) The pump horsepower, pump model and impeller size shall be clearly shown in bold print on the plans next to the drawing of the pumps and wet well. Future impeller cuts and pumping rates must be shown on the plans.
  
- 7.) Upon installation, all pumps shall be checked by a manufacturer's representative for proper rotation, pumping capacity, amperage draw, lack of vibration, and other checks as may be deemed necessary to assure proper operation. All submersible pumps shall be pulled out of and reinstalled in the wet well in the presence of a representative of the Authority to assure proper clearances for easy removal of the pumps for maintenance. (Min. 2 day start-up time for all lift stations.)

#### **403. WET WELL**

- 1.) Wet wells shall be a minimum of six feet (6) in diameter. Rectangular wet wells shall be allowed upon approval of the Authority. Sizing of wet wells shall be as follows:

For lift station pumping,  $V_{\min} = T_{\min} \times Q/4$ , where:

$V_{\min}$  = The minimum effective wet well volume in gallons. This effective volume is the volume between the "Pumps On" and the "Pumps Off" elevations. The "Pumps On" elevation shall be a minimum of 2'-0" below the invert of the inflow pipe.

$T_{\min}$  = The minimum cycle time in minutes. All lift stations shall be sized based on six starts per hour or  $T_{\min} = 10$  minutes. Although most pumps are rated at much higher starts per hour, the size is set at six starts per hour due to the limited number of starts per hour allowed by the electrical hardware. Ideal cycle time is achieved when the pump capacity (Q) is two times the inflow.

Q = Pump capacity in GPM.

- 2.) The wet well subgrade must have a minimum 95% Std. proctor and a minimum of twenty-four inch #57 stone base.
- 3.) All wastewater lift stations shall be designed so that the base elbow to the submersible pumps be mounted on a grout shelf approximately one foot above the base slab or to the pump manufacturer's recommendations. The base elbow shall be anchored to the base slab with four  $\frac{3}{4}$ " stainless steel bolts – 5000 pound pull-out each. Bolts shall be threaded into concrete a minimum of 8". Anchor inserts shall be cast into the invert. Carbon steel bolts shall not be accepted.
- 4.) All miscellaneous metals inside the wet well shall be stainless steel. Typical wet well pipe supports shall be constructed of stainless steel with stainless steel mounting hardware. Bracket shall be a minimum of 3" x 3" x  $\frac{5}{16}$ ". Pipe strap shall be minimum 3" x  $\frac{5}{16}$ " with minimum  $\frac{1}{2}$ " stainless steel bolts. Base of support shall be constructed of  $\frac{5}{16}$ " stainless steel plate mounted with  $\frac{3}{4}$ " stainless steel bolts.
- 5.) A vent for the wet well shall be supplied constructed of ductile iron pipe. The vent shall be a minimum of 6" diameter floor pipe, FL. x P.E., shall be cast in place and shall extend 6" up from the top of the wet well. A 1'-0" long D.I.P. FL. x FL. spool shall be connected to the floor pipe and two 6" diameter 90 degree bends shall be mounted to the spool to complete the vent pipe. A stainless steel bird screen shall be attached to the open end of the bend.
- 6.) For wet wells larger in area than a ten (10) foot diameter well, squirrel cage type ventilator fans shall be supplied and shall have enough capacity to provide a minimum of six air changes per hour. The fan shall include mounting curb, bird screen and explosion-proof motor. Acceptable manufacturers are Penn, Acme and Twin City Blowers or alternate acceptable to the Authority.
- 7.) The wet well influent line(s) shall be provided with a channel grinder by Franklin Miller, JWC, or alternate acceptable to the Authority. Stations equipped with grinder pumps may be exempt from the channel grinder but may still require the removable aluminum trash basket(s) with guide rails connected for easy removal via the wet well access. The basket shall be 8" x 20" x 28" as detailed by Halliday Products Series B1A. The basket shall have 2" diameter holes at 3" on center each way. The guide rails shall be mounted to the wet well walls, and shall be as detailed by Halliday Products Series B1A or alternate acceptable to the Authority.
- 8.) A lift station wet well access ladder shall be provided. The ladder is to be constructed of materials not likely to be affected by the corrosive atmosphere of the wet well. The ladder is to be permanently mounted in the wet well to provide access for maintenance. Cast-in concrete steps will not be acceptable as an access ladder. The ladder steps shall be roughened to deter foot slippage. Minimum ladder width shall be 18 inches. Ladder shall be equipped with "Safety-Climb" and must be easily accessible.

- 9.) **Odor control equipment is required on all new sewer lift stations.** Proposed odor control equipment is subject to review and approval by C.C.W.S.A. on a case by case basis.

#### **404. CHECK VALVE VAULTS**

- 1.) Lift station check valves, isolation valves, and surge control valves (if required) shall be housed in a concrete valve pit adjacent to the lift station. Check valves provided shall be slow-closing check valves. Floor drain (3" diameter minimum) for the valve pit shall be provided and connected to the wet well. A P-trap shall be installed in the floor drain to block sewer gases from the wet well. Valve pits must be large enough for easy maintenance operations, with 2' to 3' clearance on all sides and with bottom of piping 2'-0" to 2'-6" off of the concrete floor. Valve pits shall be no deeper than 8' deep. Valve pits must have easy access. A hatch opening must be placed directly over the steps so that the steps are not recessed back away from the hatch opening. See Detail S731.
- Acceptable manufacturers are as follows:**  
**Check Valves:** Golden-Anderson, Crispin or alternate acceptable to the Authority  
**Isolation Valves:** Dezurik, Val-Matic, M&H or alternate acceptable to the Authority  
**Surge Relief Valves:** Golden-Anderson or alternate acceptable to the Authority  
**Air Release Valves:** Hawle or alternate acceptable to the Authority. (Section 507)
- 2.) The discharge pipe inside the check valve vault shall be tapped for a discharge pressure gauge. The gauge shall be Ashcroft Type 1009 or alternate acceptable to the Authority, Liquid-filled, 3 ½" dial, 0-200 PSI Range with a diaphragm seal suitable for wastewater service. An isolation valve shall be supplied between the pipe and the gauge.
- 3.) All pipes in the valve vault shall be supported by either flanged pipe supports or concrete pier pipe supports. All piping in the valve vault shall be restrained using stainless steel threaded rod.
- 4.) A quarter turn plug valve shall be installed on the force main just outside the valve vault but within the chain linked fenced area of the lift station. Valve must be accessible by valve key. Valve port must be 100% of pipe diameter. Manufactures shall be DeZURIK 100% port eccentric (PEF), Val-Matic model 5600R 100% ported eccentric, or alternate acceptable by the Authority.

## **405. PUMP CONTROL PANEL**

- 1.) For lift stations less than 100 HP, controls and electrical components shall be housed in completely weather proof stainless steel metal cabinets (NEMA 4X stainless steel). The cabinets shall be provided with condensate heaters, spare fuses and spare bulbs of each type that is used in the electrical/control system. Soft start starters shall be acceptable in NEMA 3R ventilated or air-cooled panels.

For lift stations that are 100 HP or larger, an electrical building shall be provided to house the electrical distribution equipment. NEMA 1A enclosures shall be used in buildings. The buildings must be provided with a heat pump for climate control within the building.

- 2.) The pump motor starters shall be provided by the pump manufacturer. Starters for motors less than 20 horsepower shall be full voltage, non-reversing, NEMA rated. Starters for 20 horsepower and larger motors shall be Square D Altistart, Allen Bradley, Solid State Reduced Voltage or alternate acceptable to the Authority.
- 3.) The Developer shall furnish a pump controller with all necessary controls including, but not limited to, the following:
  - a.) Provide starters for each pump. (See description under Part 10 of this section.)
  - b.) HOA Switches
  - c.) Pilot Lights
  - d.) Power Indicator Lights
  - e.) Other Lights as Required
  - f.) Alarm Silence Push Button
  - g.) Alarm Reset Button
  - h.) Elapsed Time Indicators
  - i.) Control Transformers – 480V to 120V Step Downs shall not be mounted inside the control panel for heat control purposes.
  - j.) Strip Heater and Thermostat
  - k.) Alarm Horn and Wiring – 120 Volt
  - l.) NEMA 4X Red Alarm Light and Wiring – 120 Volt
  - m.) Phase Under Voltage Monitor With Time Delay
  - n.) Moisture Sensing Seal Failure Relays With Indicator
  - o.) Provide Alarm Outputs For High Water Alarms and Pump Trouble For Each Pump. Coordinate With SCADA Unit Manufacturer For Types of Outputs Required. Note: The Pump Trouble Outputs Are To Have No Time Delay Added.
  - p.) Provide Relays for Phase Failure and Phase Unbalance Protection.
  - q.) Provide Lag Pump On Delay Timer Relay, 0-60 Seconds For Each Pump, Such That The Pumps Cannot Start At The Same Time.
  - r.) Provide Pump Failure Alarm Output For Each Motor To Include Motor Overload, Motor Thermal Cutout and Leak Seal Failure (FLS) Conditions.

- s.) Only the high level and low level alarms are to be wired to the alarm horn and red light. No pump failures shall be wired to the horn and light circuit.
  - t.) Breakers for security lighting, generator block heater, and battery charger. Add two spare 120V breakers.
  - u.) Provide Terminal Blocks For All Connections Into and Out Of the Panel.
- 4.) Phase converters will not be used on lift station electrical power supply. Lift station power shall be 240 VAC / 3 phase or 480 VAC / 3 phase and control circuits shall be 120 VAC / 1 phase.
  - 5.) All 480V circuit breakers in the pump control panel shall be rated a minimum of 14 KAIC and all 240V and 120V circuit breakers shall be rated a minimum of 10 KAIC.
  - 6.) All wiring shall be done in rigid galvanized steel conduit. Conduit installed below grade shall be painted with two coats of asphaltum paint. Schedule 40 PVC conduit may be used for conduit runs underground. All PVC conduit shall be installed in concrete duct banks per NEC. Concrete ducts shall be poured monolithically with steel reinforcement as necessary.

#### **406. SCADA REQUIREMENTS**

- 1.) The control panel manufacturer shall coordinate with the pump manufacturer and the generator manufacturer, such that the SCADA system can be installed into the control panel. The control panel shall be sized such that there is adequate space for this equipment. The control panel manufacturer shall coordinate the receipt and installation of the SCADA equipment in the control panel. Make all connections between the SCADA equipment and the pump controls as required by the SCADA manufacturer.
- 2.) Each lift station shall be provided with a Remote Terminal Unit (RTU) to communicate with the Authority's SCADA System as provided by Dexter Fortson Associates, Inc, or alternate acceptable to the Authority to include any and all radio repeater site/station required to communicate with the SCADA system. Each RTU at a minimum will provide the following monitoring/control points:
  - a.) Each Phase Voltage, Current, And Power Factor For Each Pump In The Station.
  - b.) Station Voltage Phase To Phase And Phase To Neutral And Current In Each Phase At The Line Side Of The Main Disconnect Switch And At The Emergency Power Input To The ATS.
  - c.) Manual On/Off Control For Each Pump From A Remote Signal To The RTU.
  - d.) Status Of Each Pump – On/Off.
  - e.) Pump Trouble Alarm For Each Pump With 20 Second Time Delay.
  - f.) Station Operation – Simplex, Duplex, Triplex Or Quadplex.
  - g.) Station On Normal Power.



- h.) Station On Emergency Power.
- i.) Generator Running.
- j.) Generator Alarm.
- k.) Maintenance Shutdown.
- l.) Man Down
- m.) SCADA Control Off
- n.) Low Wet Well Alarm
- o.) High Wet Well Alarm
- p.) Alarm Acknowledge / Silence
- q.) Manual Off / On
- r.) Generator Fuel Tank Leak Alarm
- s.) Generator Start/Stop From A Remote Signal To The RTU.
- t.) Provide Alternator For The Operation Of Pumps (Triplex And Quadplex Only).
- u.) ATS Open (Normal Power) and Closed (Emergency Power) Indication.
- v.) Control Voltage Alarm.
- w.) Status of Control Voltage To The RTU.3

- 3.) Line power shall be provided with a quick disconnect and a transient voltage surge suppressor at the main service entrance. Disconnects shall utilize a solid state circuit breaker.

#### **407. SITE REQUIREMENTS**

- 1.) A freeze proof yard hydrant of not less than 3/4 inch size shall be provided at each lift station for washdown purposes. The potable water line shall be equipped with a reduced pressure zone backflow preventer in an above-ground housing. Backflow preventers must have a 120 VAC receptacle in the housing with electrical heat tape installed. The backflow assembly must be raised at least 12" above the concrete floor. (See the details in the Authority's Cross-Connection Control Program in (WATER/SECTION 700). A water meter must be installed for the lift station by the developer. Meter will be supplied to the developer by the Authority.
- 2.) Access roads to any lift station shall be paved. Roads shall have a minimum of 8" of graded aggregate base topped with a minimum of 2" of asphalt Type "B" or 6" of reinforced concrete with control joints every 10 feet. Roads shall be a minimum of 12 feet wide. A paved area inside the fencing shall be provided to facilitate service vehicle access to the pumping station wet well and other facilities. A paved turn around area shall be provided at each pumping station. All paved areas shall be contiguous with the paved access driveway.
- 3.) Lift station sites shall be fenced with a minimum of 6 foot high chain link fencing topped with 3 strands of barbed wire. The fenced area must be 50 feet by 50 feet minimum with a 14 foot wide chain link gate. (See Detail S729) A cantilever gate shall be installed on the driveway entrance at the public right-of-way. Access gates shall be a minimum of 14 feet in width.

- 4.) All lift stations shall be provided with security lighting. Security light must be mounted on a hinged pole with winch. Standard pole shall be a galvanized steel hinged square pole, General Electric No. ASHS-(XX)-2T-4.011 GV, 16 to 20 feet in height, with a General Electric No. M180 Winch/Chain and a No. RBSU2H6 GV Bracket. The security light attached to the top of the pole shall be a General Electric No. M2RR-07-S-1-H-2-LN-PEC1TL (Typ. for 2 lights) or alternate acceptable to the Authority
- 5.) All area inside the lift station chain link fence and extending 2 feet outside the fence shall be asphalt or concrete.
- 6.) The sewage lift station access road and area within the fence shall be above the 100 year floodplain. The construction plans shall show the floodplain limits.

#### **408. EMERGENCY POWER REQUIREMENTS**

- 1.) The minimum requirement for the provision of emergency power for lift stations shall be that each station shall be provided with an emergency generator capable of starting and running the appropriate number of pumps necessary to meet and/or exceed the maximum daily demand of the pump station and other ancillary devices. The generator shall be diesel powered with an automatic transfer switch and provisions for an automatic exercise cycle. The Contractor shall set the ATS transfer delay from utility to generator at a 30 second delay.
- 2.) The generator set shall be manufactured by Generac, Cummins Onan, Katolight, Caterpillar or alternate acceptable to the Authority.
- 3.) The generator and control panel shall be field located by the Wastewater Pumping System Manager. The generator pad thickness shall be 12" installed such that the bottom of the pad is six inches below grade and the top of the pad is six inches above grade.
- 4.) The person responsible for sizing the KW rating of the standby generator must supply a letter to the Developer, Contractor and Cherokee County Water and Sewerage Authority, stating that they guarantee the unit will operate the lift station pumps and other electrical demands with no greater than a 20% voltage dip. This letter must be signed and delivered before the day of scheduled start up.
- 5.) This specification defines the requirements for an emergency or standby Electric Generator Set. The generator set shall consist of an engine directly coupled to an electric generator, together with the necessary controls and accessories to provide electric power for the duration of any failure of the normal power supply. The generator set shall have the following characteristics:

Voltage	480 VAC or 230 VAC
Phase	3
Connection	Y
Wire	4
Hertz	60
Power Factor	0.8

- 6.) The generator set shall be capable of starting and running the necessary loads without exceeding the maximum voltage and frequency variations specified herein, or the maximum temperature limitations of the engine and generator.
- 7.) All materials and parts of the generator set shall be new and unused. Each component shall be of current manufacture from a firm regularly engaged in the production of such equipment. Units and components offered under these specifications shall be covered by the manufacturer's standard warranty on new machines, a copy of which shall be included in the submittal.
- 8.) The Authority shall accept only engine driven generator sets that can be properly maintained and serviced without causing the Authority to either carry expensive parts stock or be subjected to the inconvenience of long periods of interrupted service because of lack of available parts. The Developer shall specify the nearest location of permanent parts outlets from which parts may be obtained.
- 9.) The rated net horsepower of the engine at the generator synchronous speed, with all accessories, shall not be less than that required to produce the KW required by Section 320.34.a.i. The horsepower rating shall take into account the generator efficiency and all parasitic losses such as fan, battery charger, etc. The generator set shall be capable of producing the required KW (without overload) for the duration of the power outage (standby rating), under the following ambient conditions:

Altitude, feet	1000
Ambient temperature range, °F	0-100
Humidity at max. ambient temp.	%80

- 10.) The system shall be free of injurious torsional and bending vibrations within a speed range from 10% below to 10% above synchronous speed.

**11.)** The engine shall be of the internal combustion type equipped to operate on No. 2 diesel fuel. Accompanying the design submittals, the Developer shall supply fuel and oil consumption estimates based on engine manufacturer's data, a copy of which shall be included in the plan submittal. The engine shall be equipped with a suitable governor to maintain frequency within limits, as specified below, by controlling engine and generator speed.

Type: isochronous

Stability: 1/4% maximum steady state frequency variation at any constant load from no load to full load.

Regulation: 1/4% maximum frequency deviation between no-load steady state and full-load steady state.

Transient: 5% maximum frequency dip on most severe motor starting condition.

Transient: 2 seconds maximum recovery time for maximum motor start.

The manual speed adjusting control shall be mechanical or electrical if located on the generator set or electrical if located in a remote control panel.

**12.)** The engine shall be electric start, provided with a solenoid energized motor, with either positive engagement or clutch drive to the engine. Lead-calcium batteries shall be furnished to provide power to the engine cranking motor. The batteries shall be designed for operation at a minimum ambient temperature of 0°F. The batteries shall be capable of a minimum of four crank cycles (rolling) of the specified prime mover and have sufficient current available for "break-away" currents for the particular engine used at the specified worse case temperature.

**13.)** A float type battery charger, compatible with the batteries selected, shall be furnished which shall maintain the starting batteries at full charge. Battery chargers for 25 kW – 200 kW shall be a 5 amp charger, 10 amp chargers for 230 kW - 800 kW, and 20 amp chargers for 900 kW - 2250 kW generators. The charging system shall permit charging from either the normal or the emergency power source. It shall have a high rate and low rate charging system. A voltmeter shall indicate the charge rate and the circuit will be protected by either fuses or circuit breakers. The charger or charging circuit shall be so designed that it will not be damaged during the engine cranking, achieved, for example, by a current limiting charger or a crank disconnect relay. It shall also be capable of recharging a discharged battery in 12 hours while carrying normal loads. The charger shall be suitable for operation at 120 volts ac, single phase.

**14.)** The engine shall be liquid cooled. The type of liquid cooling system shall be a unit mounted radiator. The radiator capacity shall be suitable for operation in the ambient temperature specified in Section 320.34.b.ii, plus the air temperature rise across the engine.

- 15.) An air cleaner and silencer shall be furnished as recommended by the engine manufacturer and shall be located and mounted as recommended by the engine manufacturer.
- 16.) An exhaust system of suitable size, configuration and material in accordance with engine manufacturers recommendations shall connect the exhaust outlet of the engine to the silencer. The type of silencer shall meet the requirements of engine manufacturers and shall be critical silencing type.
- 17.) The exhaust system and silencer shall have the configuration shown on the plans submitted, and shall be of such size that back pressure on the system will not exceed the back pressure permitted by the manufacturer's recommendation. A flexible connection shall be mounted at the engine exhaust outlet and the discharge end of the exhaust line shall be protected against entry of precipitation. Screening or suitable lagging shall protect piping within reach of personnel. All exhaust piping shall be gas tight.
- 18.) The following engine protective devices shall be provided, and an indicating light shall be supplied for use with each device specified:
- Alarm system for high water temperature.
  - Alarm system for low oil pressure.
  - Automatic engine shutdown for high water temperature.
  - Automatic engine shutdown for low oil pressure.
  - Alarm and shutdown system for high water temperature.
  - Alarm and shutdown system for low oil pressure.
  - Engine over-speed automatic shutdown device.
  - Engine failed to start indicator light (over-crank).
  - Alarm for low coolant level.

A shunt trip and under-voltage trip shall be incorporated to cause the circuit breaker to open simultaneously with any automatic shutdown of the engine.

- 19.) A dual wall sub-base fuel tank shall be supplied with the generator set, which will allow the generator to operate continuously under pump load for 72 hours, but shall not exceed 1,000 U.S. gallons. The tank shall be constructed of aluminized steel with all access ports and vents located on the top horizontal surface. The tank shall be pressure and load tested according to U.L. 142 and shall be U.L. listed. The tank shall be capable of supporting the weight of the generator, isolator, and enclosure, and shall have four lifting eyes capable of lifting the entire generator set package. Low level and leak detector float switches shall be provided, both wired to control panel alarm lights, and a tank mounted fuel gauge.

**The generator fuel storage tank shall be completely filled with fuel by the**

**Developer before start-up of the lift station and topped off after start-up.**

- 20.)** The generator shall be equipped with a permanent magnet generator (PMG) excitation system. Both the PMG and the rotating brushless exciter shall be mounted outboard of the bearing. The system shall supply a minimum short circuit support current of 300% of the standby rating for 10 seconds. The rotating exciter shall use a three-phase full wave rectifier assembly with hermetically sealed silicon diodes protected against abnormal transient conditions by a multiplate selenium surge protector.
- 21.)** The insulation system of both the rotor and stator shall be of NEMA Class H materials and shall be synthetic and non-hygroscopic. Field windings shall be on the rotor, and the rotor core shall be shrunk-fit and keyed to the shaft. The stator winding shall use an optimum pitch design to eliminate harmonics. Units rated above 1500 kW or 601 volts or higher shall be form wound. The temperature rise of both the rotor and the stator shall be in accordance with the applicable sections of NEMA MG-1-22, BS-5000 part 99, or CSA C22.2, for the type of service intended. The generator shall be self-ventilated.
- 22.)** Load connections shall be made in the front-end mounted junction box. The generator construction will allow connection to the load through the top, bottom or either side of the junction box. The conduit box shall contain two compartments: one to house the rotating rectifier and PMG, and the other to house the connection area and regulator. This is to separate the rotating elements from the load connection and voltage regulator adjustments.
- 23.)** The generator shall be equipped with a voltage regulator to maintain voltage within limits as specified below:
- Stability: 1/2% maximum voltage variation at any constant load from no load to full load.
- Regulation: 1% maximum voltage between no load steady state and full load steady state.
- Transient: 20% maximum voltage dip in most severe motor starting condition.
- Transient: 2 seconds maximum voltage recovery time with application or removal of 0.8 P.F. full load.

The regulator shall be a solid-state type using transistors or SCR's. The unit shall include volts/hertz underspeed protection, 3 phase RMS sensing, and overexcitation protection. The regulator shall also provide loss of sensing protection, regulator current limit, temperature protection and an engine unloading circuit. EMI suppression shall be provided meeting MIL-STD-461B, part 9 standards.

**24.)** A generator main circuit breaker shall be provided. The interrupting capability shall be greater than the generator short circuit capability, but not less than 30,000 symmetrical amperes at 480 volts. The breaker continuous current trip rating shall be selected to provide overload protection for the generator. Main circuit breaker shall have GFCI protection per NEC.

The breaker shall be provided with a shunt trip device. The generator starting circuit battery system will be used as the power source for the shunt trip circuit. The shunt trip coil voltage shall be suitable for use on the starting circuit. The breaker shall include 3 normally open and 3 normally closed auxiliary contacts. The breaker shall be a Square D Type MA, or alternate as manufactured by General Electric, Merlin Gerin, Eaton/Cutler-Hammer or alternate acceptable to the Authority.

**25.)** Automatic starting and stopping controls shall be furnished to start the engine automatically when the normal electric power fails or falls below specific limits and to stop the engine automatically after the normal power supply resumes. The signal for starting or stopping the engine shall be from an external auxiliary contact. The controls shall be capable of operating at 50% of normal DC system supplied voltage.

**26.)** Crank control and time delay relays shall provide at least four cranking periods. Each cranking period shall be for at least 7 seconds, and the cranking attempts shall be separated by appropriate rest periods. A sensing device shall automatically disconnect the starting circuit when the engine has started. If the engine has not started at completion of the starting program, the over-cranking signal shall so indicate. The engine starting controls shall be locked out and no further starting attempts shall take place until the over-cranking device has been manually reset.

**27.)** A selector switch shall be incorporated in the automatic engine start and stop controls. It shall include an "off" position that prevents manual or automatic starting of the engine, a "manual" or "handcrank" position that permits the engine to be started manually by the pushbutton on the control cabinet and run unloaded; an "automatic" position which readies the system for automatic start or stop on demand of the automatic load transfer switch or a programmed exerciser.

**28.)** It shall be possible to start the engine manually and run it unloaded by a manual pushbutton on the control cabinet that causes the engine to start, run and stop through the automatic start and stop controls.

29.) The following engine and generator instruments and controls shall be furnished and installed:

- A.C. ammeter
- A.C. voltmeter
- Voltage adjusting rheostat
- Battery Voltage Meter
- Governor speed adjusting control
- Water temperature gauge
- Oil Pressure gauge
- Manual start/stop control
- Manual-Off-Auto mode switch
- Voltmeter/ammeter phase selector switch
- Generator "Run" Status Dry Contacts (SCADA USE)**
- Common Alarm Dry Contacts (SCADA USE)**
- Elapsed time meter
- Panel lights
- Indicator lights for engine alarm

All wiring and interconnections shall be in accordance with commercial electrical standards.

30.) Weatherproof, sound attenuating, outdoor enclosure. 14 gauge steel construction. Includes two (2) single access doors per side. Painted standard alkyd enamel finish. The Authority shall make the determination if the enclosure shall be sound attenuated for a commercial installation or residential installation. The Authority shall also make the determination as to the dBA level of attenuation required as each case may be unique. 65 dBA @ 7 meters will be considered the standard starting point for attenuation. Exhaust roof dress cap, silencer mounting brackets, exhaust system assembly including the above mentioned silencer designed to go inside the enclosure with flex, elbow and rain cap. Painted standard alkyd enamel finish. Oil and water drains are extended to the exterior of the enclosure, each with identifying nameplate.

The enclosure shall be provided with the following electrical accessories:

- Junction boxes for battery charger and jacket water heater connection.
- Connection for low alarm, high alarm, leak alarm, and fuel fill pump switch.

31.) An engine block heater shall be provided to keep the engine coolant at a temperature of 85 degree F with the ambient temperature. The heater shall be suitable for operation at 120 volts ac, single phase. External only; No internal elements shall be inside the engine.

32.) All generators sitting on fuel tanks must have a painted steel or aluminum "Catwalk" all the way around the unit for service.



33.) The system supplier shall furnish 3 sets of operating, maintenance and parts manuals covering all components for the generator set. The supplier shall also instruct the Authority in operation and maintenance of the unit.

#### 409. GENERATOR TRANSFER SWITCH

- 1.) The automatic transfer switch shall be manufactured by Generac, ASCO, Zenith or alternate acceptable to the Authority.
- 2.) The transfer switch shall be rated for total normal and emergency system transfer for use on a 480 or 230 VAC, 3 phase, 4 wire system.
- 3.) Each automatic transfer switch shall consist of a power transfer module and a control module, interconnected to provide complete automatic operation. The automatic transfer switch shall be mechanically held and electrically operated by a single-solenoid mechanism energized from the source to which the load is to be transferred. The switch shall be rated for continuous duty and be inherently double throw. The switch shall be mechanically interlocked to ensure only one of two possible positions, normal and emergency.
- 4.) The automatic transfer switch shall conform to the requirements of NEMA Standard ICS-2-447 and Underwriters' Laboratories UL-1008 and shall be UL listed as follows:
  - For use in emergency systems in accordance with Articles 700, 701, and 702 of the National Electrical Code.
  - Rated in amperes for total system transfer including control of motors, electric discharge lamps, electric heating and tungsten filament lamp loads as referred to in Paragraph 30.9 of UL-1008.
- 5.) Sensing and control logic shall be solid-state. Interfacing relays shall be industrial control grade plug-in type with dust covers.

All phases of the normal shall be monitored line-to-line. Close differential voltage sensing shall be provided. The pickup voltage shall be field adjustable from 85% to 100% of nominal and the dropout voltage shall be adjustable from 75% to 95% of the pickup value. The transfer to emergency will be initiated upon reduction of normal source to 85% of nominal voltage and retransfer to normal shall occur when normal source restores to 95% of nominal.

The following time delays shall be provided:

- A time delay to override momentary normal source outages. The time delay shall be field adjustable from 0.5 to 6 seconds and factory set at 1 second.
- A time delay on retransfer to normal source. The time delay shall be automatically bypassed if the emergency source fails and normal source is available. The time delay shall be field adjustable from 0 to 30 minutes and factory set at 5 minutes.
- An unloaded running time delay for emergency generator cool down. The time delay shall be field adjustable from 0 to 5 minutes and factory set at 5 minutes.
- A time delay on transfer to emergency. The time delay shall be field adjustable from 0 to 5 minutes for controlled timing of load transfer to emergency, and factory set at zero.

The following features and accessories shall be provided:

- Independent single phase voltage and frequency sensing of emergency source. The pickup voltage shall be adjustable from 85% to 100% of nominal. Pickup frequency shall be adjustable from 90% to 100% of nominal. Transfer to emergency upon normal source failure when emergency source voltage is 90% or more of nominal and frequency is 95% or more of nominal.
  - A contact that closes when normal source fails and one that opens when normal source fails, rated 10 Amps, 120V ac.
  - A white signal light to indicate when the automatic transfer switch is connected to the normal source. A yellow signal light to indicate when the automatic transfer switch is connected to the emergency source.
  - Two auxiliary contacts that are closed when the automatic transfer switch is connected to normal and two auxiliary contacts that are closed when the automatic transfer switch is connected to emergency. Rated 10 Amps, 120 volts, 60 Hz. AC.
  - A test switch to momentarily simulate normal source failure.
  - Reset switch to manually bypass time delay on retransfer to normal.
  - A permissive start/stop feature to provide for start/stop of the generator from a remote site regardless of the presence of normal utility power.
- 6.) The automatic transfer switch shall be mounted in a NEMA 4X for outdoor installations or a NEMA 1A for indoor non-ventilated installations.
- 7.) Copies of installation drawings and complete wiring diagrams and interconnections shall be furnished to the Authority.
- 8.) Each automatic transfer switch shall be furnished with 3 sets of the operator's manual providing installation and operating instructions.

#### **410. WASTEWATER TREATMENT PLANTS (PUBLIC AND PRIVATE)**

All sanitary sewer treatment facilities that are constructed within the boundaries of Cherokee County, and are located outside of municipalities which have the ability to treat sewage (such as Canton and Woodstock), shall be designed and constructed in accordance with the specifications of the EPD, the Ten States Standards and the Authority. Where requirements conflict, the more restrictive of the requirements shall govern. the Authority shall have the final review authority over the design of the treatment facility. Any revisions to the design made during construction must be approved by the Authority

# SECTION 500 - MATERIALS FOR SANITARY SEWERS

## 501. GENERAL

All materials used in the work including equipment shall be new and unused materials of a reputable U.S. Manufacturer conforming to the applicable requirements of these Standards, and no materials shall be used in the work until they have been approved by the Authority. Any reference to an AWWA, ANSI or other such specification shall mean the latest revision published.

## 502. GRAVITY SEWER PIPE

All sanitary sewer pipe up through 24-inch diameter must be Polyvinyl Chloride (PVC), Ductile Iron Pipe (DIP), or Steel Pipe, except where D.I.P. or Steel Pipe are required. For pipe larger than 24-inches, the Contractor may have the option of using either High Density Polyethylene (HDPE), Polyvinyl Chloride (PVC), Reinforced Concrete Pipe (R.C.P.), Ductile Iron Pipe or Steel Pipe, except where Ductile Iron Pipe (DIP) or Steel Pipe are required. All pipe shall be installed with a minimum of Class "C" bedding.

### 1.) DUCTILE IRON PIPE (DIP)

Ductile iron sewer pipe shall be required at all utility or storm sewer crossings with less than 2 feet of clearance, in cross country locations where cover is less than 3 feet, in streets where cover is less than 5 feet, in subdivision easements between lots, in fills, and where PVC sewer pipe has more than 16 feet of cover.

Ductile Iron Pipe shall be designed in accordance with AWWA C150. The thickness and class of the pipe shall be governed by AWWA C150. Ductile Iron Pipe shall be manufactured in accordance with AWWA C151, and shall have an outside bitumastic coating per AWWA C151.

The interior lining of the pipe and fittings shall be Protecto 401 ceramic epoxy with a minimum thickness of 40 mils. **Both bare pipe and cement linings conforming to AWWA C104 are NOT allowed for any sanitary sewer pipe.**

#### Joints

DIP joints shall be of the bell and spigot type with push-on joints, conforming to AWWA C111, unless another type of restrained joint is required by the Authority.

## Maximum Depth of Cover

The table below indicates the maximum depth of cover for varying thickness classes and laying conditions:

Nominal Pipe Size, Inches	Thickness Class	Maximum Depth of Cover Per Laying Condition In Feet	
		Type 4	Type 5
8"	50	46	64
8"	51	61	81
8"	52	77	99
10"	50	38	55
10"	51	49	66
10"	52	59	79
12"	50	36	52
12"	51	43	60
12"	52	53	71
16"	50	30	47
16"	51	34	51
16"	52	40	57
20"	50	27	38
20"	51	30	44
20"	52	34	50
24"	50	23	31
24"	51	27	36
24"	52	30	41
30"	50	18	25
30"	51	21	29
30"	52	24	33
36"	50	17	25
36"	51	20	28
36"	52	24	32

For further information on larger diameter pipe and thicker walls than those presented in this table, refer to AWWA C150. The laying conditions, Types 4 and 5 are also described in AWWA C150.

Where transitioning from DIP to PVC, solid sleeves are required if the pipe sizes are the same. Where pipe sizes differ, such as when installing 15" P.V.C. and 16" D.I.P., the Developer shall install D.I.P. for the entire length between the two manholes.

## 2.) POLYVINYL CHLORIDE (PVC) SEWER PIPE

### Scope

The Contractor shall provide un-plasticized polyvinyl chloride (PVC) plastic gravity sewer pipe meeting the requirements shown below unless otherwise required by the Authority

### Materials

Pipe and fittings shall meet the requirements as specified under ASTM D3034 for PVC pipe through 15" in diameter and ASTM F679 for pipe 18" through 24" in diameter. All pipe and fittings shall be suitable for use as a gravity sewer conduit. Bell joints shall consist of an integral wall section with elastomeric gasket joint which provides a watertight seal. Standard laying lengths shall be 20.0 feet ( $\pm$  1 inch). The pipe shall be capable of passing all tests which are detailed in this specification. Minimum wall thickness shall be as follows:

<u>ASTM D3034</u>	<u>ASTM F679</u>
4" - 0.120 inches	18" - 0.536 inches
6" - 0.180 inches	21" - 0.632 inches
8" - 0.240 inches	24" - 0.711 inches
10" - 0.300 inches	
12" - 0.360 inches	
15" - 0.437 inches	

### Fittings

All fittings and accessories shall be manufactured and furnished by the pipe supplier. They shall have bell and/or spigot configurations compatible with that of the pipe and shall have an equivalent wall thickness.

### Pipe and Fittings Tests

The Contractor will be required to furnish a written outline of the manufacturer's quality control program for the Engineer's approval prior to shipping any pipe to the project. Before installing any pipe the Contractor shall furnish written certification that all pipe through 15" in diameter meets ASTM Specification D3034 and all pipe 18" through 24" in diameter meets ASTM F679. At least one sample from each 100 pieces of pipe furnished shall be subjected to each test outlined under Section 8 of ASTM D3034. The samples will be tested by an independent laboratory approved by the Authority, and a certified copy of results will be furnished to the Authority. If any test is not met then 9 additional tests of that property will be ordered, and if any of these 9 tests are not met, the manufacturer will not be allowed to furnish materials for the project. The cost of all testing shall be at the Developer's expense.

### **Pipe Stiffness**

Minimum "pipe stiffness" (F/Y) at 5 percent deflection shall be 46 psi for all sizes, when tested in accordance with ASTM Standard Method of Test D2412, to determine the "External Loading Properties of Plastic Pipe by Parallel Plat Loading". There shall be no evidence of splitting, cracking, or breaking at a deflection of up to 30 percent of the original diameter.

### **Fusion Quality**

There shall be no evidence of flaking, swelling, or disintegration when the pipe material is tested in accordance with ASTM D2152, "Quality of Extruded Poly (Vinyl Chloride) pipe by Acetone Immersion".

### **Joint Tightness**

Pipe and fitting joints shall comply with ASTM D3212 for "Joints for Drain and Sewer Plastic Pipes Using Flexible Elastomeric Seals". Joint assemblies shall not leak when subjected to both an internal and external hydrostatic test at equivalent pressures of 10.8 psi gauge for a period of one hour. Pipes shall be tested in straight alignment, axially deflected position, and by shear load test as otherwise defined in Paragraphs 7.2, 7.3, and 7.4 of ASTM D3212.

### **Installation**

PVC pipe will be installed in accordance with ASTM D2321. In any area where the pipe is below existing ground water level, the contractor will embed PVC pipe in sand or graded gravel. No special compaction requirements will be necessary; however, the sand or gravel must extend from six inches below the pipe to twelve inches above the pipe, and the material must be firmly placed under the pipe haunches. When embedding PVC pipe in friable, compressible soils (Eg. silt, clay, sandy clay, silty clays, etc.), special care must be exercised to provide a uniform (undisturbed or fully compacted) trench bottom. Additionally, the backfill must be compacted to 95% standard proctor in 6" - 8" lifts to twelve inches above the top of the pipe. Initial backfill shall be compacted to the densities outlined in D2321. The Authority may require random compaction tests to insure compliance with D2321. If any material tested is less than the required density, the contractor shall re-compact said material and the Authority shall then have the right to additional compaction tests at the expense of the Developer to insure compliance with D2321.

The Contractor shall use SDR-35 material for pipe with 0-16 feet of fill. PVC pipe cannot be used at depths exceeding 16 feet.

### **Deflection Limit**

Vertical deflection of installed pipe shall not exceed 5 percent of the un-deflected diameter as defined in Table X1.1 of ASTM D3034.

## **3.) HIGH DENSITY POLYETHYLENE PIPE (HDPE)**

### **Scope**

This specification covers the requirements of high density polyethylene profile wall gravity sewer and drain pipe fittings in nominal sizes 18 through 96 inches with integral bell and spigot gasketed and welded joints. Note: HDPE pipe is acceptable only for trenchless technology applications and for small diameter (< 4") force mains. The designer shall not specify HDPE pipe for open-cut gravity sewers.

### **Classes**

Class selection for high density polyethylene profile wall sewer pipe shall be a minimum of Class 160 for pipe with 0-16 feet of fill. HDPE cannot be used at depths exceeding 16 feet.

### **Material**

Pipes and fittings shall be manufactured from high density polyethylene resin compound which shall meet the requirements of Type III, Class C, Category 5, Grade P 34 per ASTM D 1248. Materials meeting the requirements of ASTM D3350 with a cell classification PE 334433C or higher are also suitable. The pipe shall contain a minimum of two percent carbon black as an ultraviolet inhibitor.

### **Pipe Dimensions**

The average inside diameter and the minimum wall thickness of the waterway of the pipe shall comply with ASTM F894 for RSC Class 160 pipe.

### **Joints**

The pipe shall be produced with bell and spigot end construction. Joining shall be accomplished by use of neoprene rubber gaskets complying with the physical requirements as specified in ASTM F477. Joints shall be in accordance with ASTM D3212 and withstand an internal operating pressure of 50 psi.



### **Pipe Stiffness**

The profile wall shall be substantially strong to protect against any diametrical deformation. All polyethylene profile wall pipe shall have a minimum specific pipe stiffness of 46 psi at a deflection of five percent of the internal diameter when tested and calculated in accordance with ASTM D24212.

### **Retest and Rejection**

If the results of any tests do not meet the requirements of this specification, the tests may be conducted again in accordance with agreement between purchaser and seller. In retesting, the product requirements of this specification shall be met and the test methods designated in this specification shall be followed. If upon retest failure occurs, the quantity of product represented by the tests shall be rejected.

### **Deflection Limit**

Vertical deflection of installed pipe shall not exceed 5 percent of the undeflected diameter as defined in Table X1.1 of ASTM D3034.

Each segment of line (except service lines) will be tested at the end of each month just prior to inspection on that segment. Upon completion of the pipe installation, and at least 30 days after installation (to allow for settling), the pipe will be tested again for final acceptance. The test shall be performed by the Contractor pulling a mandrel of specified dimensions through the pipeline.

## **4.) REINFORCED CONCRETE PIPE (RCP)**

### **Scope**

The work included in this section includes furnishing all labor, equipment, and materials required to install, test, and inspect reinforced concrete (ASTM C-76) pipe sanitary sewers, including all risers, plugs, fittings, and bedding, as shown on the drawings and/or specified herein.

## **Quality Assurance**

The Contractor must submit to the Owner and Engineer the concrete pipe manufacturer's evidence of a working Quality Control Program for approval prior to any pipe being manufactured. The program and standards of manufacturing must be established and well defined. The program must include the minimum following requirements:

- A full time Quality Control Technician.
- A complete and working Quality Control Laboratory capable of testing and recording the requirements set forth in these Specifications for concrete pipe.
- Written documentation of the concrete pipe manufacturer's performance on a recent sewer project. The performance results must be from a tested and approved installation of the pipe material set forth in this specification from either the Owner and/or Engineer stating that the pipe tested and met the requirements.
- A zero defect program for daily material testing and finished product testing to assure quality control as the pipe is being manufactured and shipped for this particular project.
- Provide the services of a competent factory representative of the pipe manufacturer for purposes of supervising and/or inspecting the installation of pipe. This service shall be for the duration of the project.
- Provide equipment and labor to air test each joint of pipe (30" dia. and larger) as it is installed. Joint tester shall be "Cherne Large Diameter Joint Tester" or equal. This testing shall in no way relieve the contractor from the responsibility of performing infiltration/exfiltration tests.

## **Testing of Concrete Pipe**

- Concrete gravity pipe (ASTM C-76) shall meet all materials and testing requirements of ASTM C-76, ASTM C-443, and ASTM C-497 (except where modified herein). Manufacturer shall secure the services of an independent testing laboratory to conduct the tests. Testing laboratory shall be approved by the Authority prior to conducting any tests. All testing costs shall be paid for by the pipe manufacturer.
- Testing shall be in Job Lots (a Job Lot is a continuous run of one size of pipe for this project) for a maximum of 6% of pipe quantity or a minimum of 5% of pipe quantity. The test specimen will have a minimum of two (2) joints for pipe of 16 foot laying length. For pipe of 12 foot laying length, the maximum number of joints shall be seven (7) and the minimum number shall be two (2). Bulkheads will be included in this joint count.
- A representative of the Developer will be present to witness all tests that are conducted at the manufacturer's site and shall record all results. Manufacturer shall notify the Developer at least 48 hours prior to conducting any tests.

- The following test shall be required:  
Pipe barrels shall be subjected to an internal hydrostatic pressure of 10 psi for 10 minutes. Pipe joints shall be subjected to an internal hydrostatic pressure of 13 psi for 10 minutes. The testing of the joints will be in the straight and deflected alignment.

The manufacturer shall conduct three (3) external load crushing strength tests per Job Lot. This test shall be by the three-edge bearing method. The test may be taken to Ultimate Load.

Absorption tests shall be conducted as per ASTM C-497. The absorption rate of the sample from the pipe wall shall not exceed 6%.

- If any test specimen fails to pass any of the above tests, two (2) additional test specimens shall be chosen at random from the Job Lot and tested. If either of those two specimens fails the test, then the entire Job Lot is subject to rejection. If the manufacturer requests further testing, then every section of pipe in the Job Lot must be tested.
- In addition to the above tests, manufacturer shall conduct tests to determine alkalinity of cover concrete as detailed in the material sub-section 5 of this concrete specification.
- Each pipe shall be clearly marked as required by the governing ASTM standard specifications to show its class, date of manufacture, and the name of trademark of the manufacturer.
- Any pipe or specials which have been broken, cracked or otherwise damaged before or after delivery or which have failed to meet the required tests, shall be removed from the site of the work and shall not be used therein.

### **Guarantee**

The Developer shall provide a guarantee against defective materials and workmanship in accordance with the requirements of the section entitled "Guarantees and Warranties" of these Standards.

### **Material**

All concrete pipe and fittings 12 inches in diameter and larger shall be reinforced concrete sewer pipe conforming to the latest requirements of ASTM C-76 with the following modifications: All concrete pipe with 0-20 feet of fill shall be a minimum of Class III with 4500 psi concrete. All pipe with 20-30 feet of fill shall be Class IV with 4500 psi concrete. All pipe with 30 feet of fill and over shall be Class V with 5500 psi concrete.

Pipe shall have circumferential reinforcement as required for the particular class of pipe furnished. The bell and spigot of the joint shall contain circumferential and longitudinal reinforcement. Reinforced concrete pipe shall be centrifugally cast or vibrated, horizontally or vertically cast or made on a Packerhead machine and shall be furnished in lengths not more than 20 feet and not less than 8 feet, except where short lengths are required for construction conditions. Reinforced concrete pipe shall have bell and spigot joints suitable for the use of a rubber gasket to be provided as a part of this item.

Concrete pipe for sanitary sewers shall have bell and spigot joints consisting of self-centering steel joint rings securely attached to the pipe reinforcing steel. The steel joint rings shall be suitable for use with a rubber O-ring type gasket to be provided as part of this item.

Bell and spigot joints consisting of self-centering steel joint rings shall have the joint rings securely attached to the pipe reinforcing steel. The rings which form the joint shall be made so that they will join with a close, sliding fit. The joint surfaces shall be such that the rubber gasket shall be confined on all sides and shall not support the weight of the pipe.

The spigot ring shall have an external groove accurately sized to receive the gasket. Special section steel for spigot rings shall conform to ASTM A-283, Grade A, or ASTM A-306, Grade 50.

The bell ring shall be flared to permit gradual deformation of the gasket when the joint is assembled. Minimum thickness of bell rings shall be 3/16 inch. Bell rings 1/4 inch or thicker shall conform to ASTM A-283, Grade A, or ASTM A-306, Grade 50. Bells less than 1/4 inch thick shall conform to ASTM A-570, Grade A.

Each ring shall be precisely sized by expansion beyond the elastic limit of the steel and then gauged on an accurate template. All exposed surfaces of both rings shall be protected by a corrosion-resistant coating of zinc applied by an approved metalizing process after proper cleaning.

### **Lining**

Acceptable interior linings shall be Koppers Bitumastic 300 M coal tar epoxy, Porter Tarsol, Wise Chem CTE 200, Amercoat 78, polyurethane or approved equal.

The interior concrete or mortar surfaces of pipe and fittings are to be sandblasted and coated with the liner in accordance with the manufacturer's recommendations. The dry film thickness of the total system shall be 40 mils minimum of polyurethane or 90 mils of coal tar epoxy on concrete or mortar surfaces and on steel joint ring surfaces.

Sandblasting shall result in a clean dry surface free of oil, grease, or other contaminants. Any air pockets over 1/4 inch in diameter and 1/8 inch deep appearing on the concrete surface after sandblasting will be filled with an epoxy sand patching material such as those sold by Sherwin-Williams, Glidden, or Moran. The epoxy sand patch should be troweled prior to the application of the coal tar epoxy.

Any steel surfaces to be painted should be sandblasted, solvent cleaned, or wire brushed prior to painting. Application of the coal tar epoxy shall be by brush, roller, or spray system using equipment recommended by the manufacturer of the coal tar epoxy system. The temperature during application and curing of coal tar epoxy shall be as recommended by the manufacturer of the coal tar epoxy. Time between coats (if applicable) shall be as recommended by the manufacturer of the liner.

If the inside joint recess will be mortared and painted with coal tar epoxy in the field, the pipe supplier shall not paint the inside vertical surfaces at the ends of the pipe. When the inside joints will not be mortared in the field, the pipe supplier shall paint the inside vertical concrete or mortar surfaces at each end of the pipe.

The liner shall be extended continuously over the front lip of the steel spigot ring and a minimum of 2 inches onto the sealing surface of unrestrained bell rings so that all interior joint surfaces which can be exposed to the fluid inside the pipe are coated.

### **STEEL PIPE**

Steel pipe shall meet the requirements of ASTM A-139 Grade B, AWWA C-200, and shall be lined with 40 mils of polyurethane or 90 mils of coal tar in accordance with AWWA C-203. Acceptable coal tar epoxy interior linings shall be Koppers Bitumastic 300 M coal tar epoxy, Porter Tasset, Wise Chem CTE 200, Amercoat 78, or approved equal. The outer coating shall be sand/grit blasted, primed to Federal Specification TTP-86C. Pipe shall have a minimum wall thickness of 0.250 inches.

## **503. SANITARY SEWER FORCE MAINS**

Force mains 4 inches in diameter or larger shall be ductile iron pipe and shall conform to section 402.A of these specifications. The interior lining of the pipe and fittings shall be Protecto 401 ceramic epoxy with a minimum thickness of 40 mils. **Both bare pipe and cement linings conforming to AWWA C104 are NOT allowed for any sanitary sewer pipe.**

Force mains smaller than 4 inches in diameter shall be CertainTeed, Eslon, Dyka, Vulcan, Class 200 SDR 21 integral bell PVC pressure pipe or approved equal. HDPE pipe is also allowable for these smaller force mains.

See Standard Details for the minimum concrete blocking requirements. Design engineer shall be responsible for design of blocking where more than the minimum is required. For internal pressures in excess of 100 PSI, blocking calculations MUST be submitted to the Cherokee County Water & Sewerage Authority for review.

All non-ferrous pipe shall be marked with the installation of detection wire installed one foot above the pipe and properly connected to valves, fittings and manhole rings so that the sewer line can be located with a pipe detector after burial.

All fittings shall be mechanical joint with retainer glands. All retainer glands shall be EBAA Mega-Lug or approved equal.

Ductile iron force mains shall be encased in green polyethylene tubing. Polyethylene encasement tubing shall be manufactured of virgin polyethylene material conforming to the requirements specified in AWWA C105, Section 4.1.1 for linear, low density polyethylene film. The polyethylene film shall have a minimum thickness of 8 mil.

## **504. PRECAST CONCRETE MANHOLES**

### **MANHOLES**

Precast manholes shall be constructed of Portland Cement concrete with a compressive strength of not less than 4,000 pounds per square inch at an age of 28 days. The wall thickness shall not be less than 5 inches. Manholes over 12' deep shall also be placed on a reinforced slab as shown on the detail sheet. Precast concrete manholes shall consist of precast reinforced concrete sections with eccentric top section, or flat slab for shallow manholes, and a base section conforming with the typical manhole details as shown on the Standard Detail Drawings. Flat top manholes will be approved only if a real need for such can be demonstrated by the design engineer. All manholes shall be water tight when completely built. Safety platforms shall be constructed in manholes in accordance with OSHA regulations and the details in these specifications.

### **MANHOLE SECTIONS**

The design, the materials used in, the manufacturing process, the testing and the transportation of precast manhole sections shall be subject to inspection at any time by the Engineer. Materials found defective by the Engineer will not be delivered to the job site. Material on the job site that is found defective shall be moved immediately after being notified that such materials are unacceptable. Precast manhole shall conform to ASTM C478. .

### **MANHOLE SECTION JOINTS**

Joints of the manhole sections shall be of the tongue-and-groove type, sections shall be joined using O-ring rubber gaskets, flexible plastic gaskets conforming to the applicable provisions of ASTM Standard Specification, Serial Designation C 433, or an approved bituminous mastic joint material.

### **LIFT HOLES**

Each section of the pre-cast manhole shall have not more than two holes for the purpose of handling and laying. These holes shall be sealed with cement mortar using one part Portland cement to two parts clean sand, meeting ASTM Standard Specifications, Serial Designation C144.

### **MANHOLE STEPS**

Manhole steps conforming to the applicable provisions of ASTM Specification C478, shall be of #4 steel reinforcing bars covered with Polypropylene Plastic or rubber and shall be supplied with depth rings and other necessary appurtenances. Steps shall be similar to and of an equal quality to the "PS-1-PF" by M. A. Industries, Inc. of Peachtree City, Ga. The step shall be factory built into the precast sections.

### **PIPE HOLES**

Holes in precast bases to receive sewer pipe shall be precast at the factory at the required locations and heights. Knocking out of holes in the field will not be permitted, however, holes can be cored in the field with a coring machine. Pre-molded rubber boots with stainless steel bands shall be used for connecting sewer pipe to manholes. These may be either the lock-in "Kor-N-Seal" type as manufactured by National Pollution Control Systems, Inc. or the cast-in type as manufactured by Interpace Division of Ball Rubber, Inc. In all cases the boot shall be sized to suit the outside diameter of the type pipe being used.

### **BASES AND INVERTS**

Manhole bases and inverts shall be constructed of 4000 psi concrete or brick in accordance with details on Standard Detail Drawings and the trough shall have the same cross-section as the sewers to which it connects. The manhole base and invert shall be carefully formed to the required size and grade by gradual and even changes in sections. Changes in direction of flow through the sewer shall be made to a true curve with as large a radius as the size of the manhole will permit. The minimum drop through a manhole shall be 0.1 foot.

### **MANHOLE FOUNDATION**

The manhole base shall be set upon a 6 inch compacted (minimum thickness) mat of Size #57 crushed stone. Manholes over 12' deep shall also be placed on a reinforced slab as shown on the detail sheet.

### **BRICK**

Brickwork required to complete the precast concrete manhole shall be constructed using 1 part portland cement to 2 parts clean sand, meeting ASTM Specifications, Serial Designation C 144, thoroughly mixed to a workable plastic mixture. Brickwork shall be constructed in a neat and workmanlike manner. Cement mortar shall be used to grout interior exposed brick joints and faces. No more than 3 courses of brick with 9 inch maximum total depth of bricks may be used to adjust manhole covers.

### **FRAME AND COVER**

Manhole covers shall be of cast iron with a coat of asphaltic paint applied at the foundry. The weight of the frame and cover shall be approximately 315 lbs. The clear opening shall be 21 1/2". The frame and cover shall be equal and similar to Neenah R-1776.

Where waterproof covers are required, the weight of the frame and cover shall be approximately 375 lbs. The clear opening shall be 24". The frame and cover shall be equal and similar to Neenah R-1915-H2 with a "bolted-down" lid.

The cast iron frame for the manhole cover shall be set at the required elevation and properly anchored to the masonry. Frames and covers shall be in compliance with the latest edition of ASTM 48. Where manholes are constructed in paved areas, the top surface of the frame and cover shall be tilted, if necessary, to conform to the exact slope, crown and grade of the existing adjacent pavement. All covers shall have "SEWER" printed on them.

### **MASONRY WORK**

Masonry work shall be allowed to set for a period of not less than 24 hours. All loose or waste material shall be removed from the interior of the manhole. The manhole cover then shall be placed and the surface in the vicinity of the work cleaned off and left in a neat and orderly condition.

## **505. STEEL CASINGS**



Steel casing pipe shall be used for all cased piping where the carrier pipe is eight inches (8") or greater in size. Steel casing pipe shall have a minimum yield strength of 35,000 psi and shall conform to the requirements of ASTM A139, Grade B, electric fusion welded steel pipe. It shall be fully coated on the exterior and interior with a coal tar varnish coating. The casing pipe diameter shall be six to eight inches greater than the "bell" diameter of the carrier pipe. Minimum wall thickness shall be as follows:

<u>Nominal Diameter (Inches)</u>	<u>Nominal Thickness (Inches)</u>
Under 14	0.250
16	0.250
18	0.250
20	0.281
22	0.312
24	0.344
28	0.406
30	0.406
36	0.469
42	0.500
48	0.625
54	0.750

#### **506. STONE AND GRAVEL MATERIALS**

All rip-rap, construction exit stone, subgrade stabilizer stone, graded aggregate base and drainage stone shall meet the requirements set forth in the **Manual For Erosion and Sediment Control In Georgia**, Appendix C - Construction Materials, latest edition.

#### **507. AIR RELEASE AND VACUUM BREAK VALVES FOR FORCE MAINS**

The valve shall be a combination air/vacuum- double orifice automatic air release valve with 2" connection to the pipe line. The valve shall be of one-piece body design. The internal parts shall have a small orifice within tripod for small air discharge and a big orifice within bonnet of base housing for main air discharge and allow air to enter in the event of a vacuum condition. The material of the body and the flow shall be Delrin (Poloximethylene,POM). The valve sealing is rubber made of EPDM. The valve shall have a protection cap of PE. Air and vacuum valves shall be manufactured by H-TEC or alternate acceptable to the Authority. Valves shall be a minimum of 1 inch.

Gate valves between water main and air release valve shall be bronze, solid wedge with screw connection equal to Jenkins Company Figure 370 or alternate acceptable to the Authority.

## **SECTION 600 - CONSTRUCTION METHODS**

### **601. EXCAVATION GENERAL**

It is the responsibility of the General Contractor, any subcontractor, their employees, and inspectors to job sites to observe all safety regulations. Deficiencies in safety measures noted should be immediately reported to the Contractor's superintendent, so that immediate corrective measures can be taken by the Contractor. It is, however, the Contractor's responsibility to conform to all safety regulations and practices as pertain to his construction site. The Contractor shall contact the U.S. Department of Labor, Occupational Safety and Health Administration (OSHA), Region IV, Atlanta, Georgia for any assistance needed to complying with the appropriate regulations.

All unsuitable excavated material must be properly disposed of in a manner acceptable to the Cherokee County Roads and Bridges Department and in a manner that will not adversely affect the environment.

It shall be expressly understood that these Standards are for the installation of all sanitary sewer mains and appurtenances. All work shall conform to the applicable provisions of the AWWA Specifications or ASTM Specifications of latest revision except as otherwise specified herein.

### **602. EROSION AND SEDIMENTATION CONTROL**

All erosion and sedimentation control methods shall be in compliance with the State, Federal and Local regulations, the Manual For Erosion Control In Georgia and the EPD requirements regarding the NPDES Storm Water Monitoring permit.

The Contractor shall designate one individual to be responsible for the implementation and maintenance of erosion and sedimentation controls on a 24-hour, everyday basis. The Contractor shall furnish the Authority the individual's name, address, and 24-hour telephone number. This information shall be updated as is necessary.

### **603. CLEARING AND GRUBBING**

Areas for sewer system construction shall be cleared and grubbed. All trees, shrubs, stumps, brush, paving and other waste material must be removed from the site. On sanitary sewer main extensions to the development, the road right-of-way or easement width shall be cleared to the width necessary for trenching and pipe laying operations. All stumps and roots within the trench dimensions shall be grubbed to such depths and widths as will enable the trenching to be done. No trees or stumps shall be pushed beyond the right-of-way / easement or any timber beyond the right-of-way / easement damaged. The Contractor shall remove only such trees on or along the work as the Chief Inspector permits, and shall carefully protect all other trees adjacent to the work. The Contractor shall not permit excavating machinery or trucks to scrape the bark or tear the limbs from the trees, nor connect ropes or guy cables to them.

### **604. TRENCH EXCAVATION**

It is the responsibility of those installing sanitary sewers, lift stations, waste treatment plants, and related appurtenances to conform to OSHA regulations, 29 CFR Part 1926, Subpart P, Paragraph 1926.650 through 1926.653 during trench excavation. OSHA publications are available to assist the Contractor in having a safe construction site (i.e. **Excavating and Trenching Operations**, 1995(Revised), OSHA 2226). Publications from OSHA can be obtained by contacting OSHA Publications Distribution, Washington, D.C. The Authority assumes no liability nor responsibility for unsafe trench conditions.

Trenches shall have a minimum width of twelve (12) inches plus the diameter of the outside of the bell of the sewer main and the depth thereof shall be such that there shall be a minimum of required cover measured below the roadway surface, natural ground, or proposed grade to the top of the pipe. The sides of the trench above the pipe shall be sloped or benched as necessary to maintain stability.

In cases where water lines cross above sanitary sewers, there shall be a minimum of 18 inches vertical separation between the water and sewer mains. At crossings, one full length of water pipe must be located so that both joints are as far from the sanitary sewer as possible. Both mains shall be D.I.P. In cases where water mains parallel sewer mains there shall be a minimum of ten (10) feet horizontal separation maintained between the mains. In cases where water mains parallel sewer mains, the water lines shall be a minimum of eighteen inches (18") above the sanitary sewer. These distances are measured edge to edge.

Pipe trenches shall be cut straight and true to the lines and grades and in the locations

shown on the plans. The bottom of the trench shall be cut carefully to the required grade of the pipe except where bedding materials or cradles are shown, in which case the excavation shall extend to the bottom of the bedding or cradles as shown on the plans. Trenches shall be dug so that the pipe can be laid to the alignment and depth required, and the trench shall be of such width and shall be braced and drained so that the workmen may work therein safely and efficiently. No chocking under the pipe will be permitted. All joints shall be as specified herein.

Bell holes shall be excavated at proper intervals so the barrel of the pipe will rest for its entire length upon the bottom of the trench and the pipe weight shall not rest on the bells. Bell holes shall be large enough to permit proper installation of all joints in the pipe.

All excavations shall be adequately guarded with barricades and lights in compliance with all OSHA, Cherokee County and the Georgia Department of Transportation requirements so as to protect the public and workers from hazard.

Pipe trenches shall not be excavated more than 100 feet in advance of pipe laying, and all work shall be performed to cause the least possible inconvenience to the public. Adequate temporary bridges or crossings shall be constructed and maintained where required to permit uninterrupted vehicular and pedestrian traffic. The Chief Inspector shall have the right to limit the amount of trench open at any one time to less than 100 feet if he believes the reduced limits are necessary.

No excavation shall be made under highways, streets, alleys or private property until satisfactory arrangements have been made with the State, City, Cherokee County Engineering or owners of the property to be crossed. All excavated material shall be placed so as to not interfere with public travel on the streets and highways along which the lines are laid.

Excavations adjacent to existing or proposed buildings and structures or in paved streets or alleys shall be adequately protected by the use of trench boxes, sheeting, shoring and bracing to prevent cave-ins of the excavation, or the undermining or subsequent settlement of adjacent structures or pavements. Underpinning of adjacent structures shall be done when necessary to maintain structures in safe condition.

Trenches shall be free of water during the work. Whenever water is present in the trench, it shall be removed in a manner satisfactory to the Authority and enough backfill shall be placed on the pipe to prevent floating. Any pipe that has floated shall be removed from the trench and re-laid later during dry conditions. No pipe shall be laid in wet trench conditions that preclude proper bedding, or on frozen trench bottom, or when, in the opinion of the Authority the trench conditions or the weather are unsuitable for proper installation.

The Contractor shall do all necessary pumping or bailing, build all drains and do all

other work necessary at his own expense to keep the trenches clear of water during the progress of the work. No structure shall be built or pipe shall be laid in water, and water shall not be allowed to flow over or rise upon any concrete, masonry or pipe until the same has been inspected and the concrete or joint material has thoroughly set. All water pumped, bailed or otherwise removed from the trench or other excavation shall be conveyed in a proper manner to a suitable place of discharge where it will not cause injury to the public health or to public or private property or to work completed or in progress, or to the surface of the streets or cause any interference with the use of same by the public.

Construction occurring around active sewer systems shall be done in such a way so as to prevent the passage of wastewater onto the ground. **Absolutely no wastewater shall be allowed to spill onto the ground.**

During the sewer line construction an effort shall be made to minimize the cutting of trees.

When possible, all crossings of paved highways or driveways shall be made by boring or jacking the pipe under the pavement and shall be done in such manner as not to damage the pavement or subgrade, unless the casing or pipe is in solid rock, in which case the crossing shall be made by the open cut method or by tunneling. Wherever streets, roads, or driveways are cut, they shall be immediately backfilled and compacted after the pipe is laid and shall be maintained in first-class condition as passable at all times until repaved. Backfilling, compaction, dressing and clean-up shall be kept as close to the line laying crew as is practical, and negligence in this feature of the work will not be tolerated.

Streets, sidewalks, parkways, and other public and private property disturbed in the course of the work shall be restored to as near as original condition as possible or better in a manner satisfactory to the Authority. The Contractor shall carefully protect all trees adjacent to the work. He shall not permit excavating machinery or trucks to scrape the bark or tear the limbs from the trees, nor connect ropes or guy cables to them. No trees or shrubs will be removed without the approval of the property owner and the CCWSA.

In excavation and backfilling and laying pipe, care must be taken not to remove or injure any water, sewer, gas or other pipes, conduits or other structures without an order from the Designer. When an obstruction is encountered, the Contractor shall notify the Designer who will have the Owners of the obstruction adjust same or make necessary changes in grade and/or alignment to avoid such obstruction. Any house connection, drains or other structures damaged by the Contractor shall be repaired or replaced immediately.

In laying pipe across water courses, the top of the sewer main or casing shall be a minimum of two feet below the creek or river bed. Four feet of cover shall be

maintained over sewer mains crossing ditches or depressions of any kind. Railroad crossings shall be installed according to American Railway Engineering Association requirements.

All excavated material shall be placed on one side of the trench, unless permission is given by the Authority to place it on both sides. Excavated materials shall be so placed as not to endanger the work and so that free access may be had at all times to all parts of the trench and to all fire hydrants, water valve boxes, manholes, etc.

**605. ROCK EXCAVATION**

Wherever rock is encountered in the excavation, it shall be removed by suitable means. Drilling and blasting operations shall be conducted with due regard for the safety of persons and property in the vicinity and in strict conformity with requirements of all ordinances, laws and regulations relative to the handling, storing and use of explosives. The Developer is fully responsible for filing for and acquiring any blasting permits which may be required by those agencies with such jurisdiction. Before blasting, the Contractor shall cover the excavation with heavy timbers and mats in such a manner as to prevent damage to persons or the adjacent property. Rock excavation near existing pipelines or other structures shall be conducted with the utmost care to avoid damage. The Contractor shall be wholly responsible for any damage resulting from blasting, and any injury or damage to structures or property shall be promptly repaired by the Contractor to the satisfaction of the Authority and property owner.

Rock in trenches shall be excavated over the horizontal limits of excavation and to depths as follows:

<u>Size of Pipeline, Inches</u>	<u>Depth of Excavation Below Bottom of Sewer Pipe, Inches</u>
4 and Less	4
4 to 6	6
8 to 18	8
18 to 30	10
Over 30	12

The space below grade for pipe lines shall then be backfilled with subgrade stabilizer or other approved bedding material and compacted.

In rock excavation, the backfill from the bottom of the trench to one foot above the top of the pipe shall be finely pulverized soil, free from rocks and stones. The rest of the backfill shall not contain over 50% broken stone, and the maximum sized stone placed in the trench shall not exceed two inches (2") in diameter. Excess rock and fragments of rock larger than 2" in diameter shall be loaded and hauled to disposal. If it is necessary, in order to comply with these specifications, selected backfill shall be borrowed and hauled to the trenches in rock excavation. Sides of the trench shall be trimmed of projecting rock that will interfere with backfilling operations. Rock excavation by blasting shall be at least 75 feet in advance of pipe laying.

## **606. SUB-GRADE AND PIPE BEDDING**

All DIP, RCP and Steel pipe shall have a minimum of Class "C" bedding. All PVC pipe shall have minimum bedding as described below and shown in the standard details. Wherever water or wet soil is encountered, Class "B" bedding shall be provided for DIP, RCP and Steel Pipe. If specifically designated on the plans, Class "A" or "B" bedding may be required. Class "D" bedding is not allowed for use with gravity sewers. All bedding shall conform to ASTM C12 specifications.

A description of Class "A", "B", "C" and PVC Special Bedding is as follows:

### **Class "A" Bedding**

Class "A" bedding refers to bedding with concrete cradle or arch. The Contractor shall conform to details shown in the detailed drawings when Class "A" bedding is required.

### **Concrete Cradle**

The sewer pipe is bedded in a cast-in-place cradle of plain or reinforced concrete having a thickness equal to one-fourth the inside pipe diameter, with a minimum of 100 mm (4 in.) and a maximum of 380 mm (15 in.) under the pipe barrel and extending up the sides for at least the outside diameter of the sewer pipe barrel plus 200 mm (8 in.). Construction procedures must be executed carefully to prevent the sewer pipe from floating off line and grade during placement of the cradle concrete.

### **Concrete Arch**

The sewer pipe is bedded in carefully compacted granular material having a minimum thickness of one-eighth the outside sewer pipe diameter but not less than 100 mm (4 in.) or more than 150 mm (6 in.) between the sewer pipe barrel and bottom of the trench excavation. Granular material is then placed to the spring line of the sewer pipe and across the full breadth of the trench. The haunching material beneath the sides of the arch must be compacted so as to be unyielding. Crushed stone in the 5-mm to 20-mm (0.25 in. to 0.75 in.) size range is the preferred material. The top half of the sewer pipe is covered with a cast-in-place plain or reinforced concrete arch having a minimum thickness of 100 mm (4 in.) or one-fourth the inside pipe diameter but not to exceed 380 mm (15 in.), and having a minimum width equal to the outside sewer pipe diameter plus 200 mm (8 in.).

### **Class "B" Bedding**

The pipe shall be bedded in crushed granite material or other suitable materials approved by the Authority. The bedding shall be placed on a flat trench bottom with a minimum thickness beneath the pipe of one-eighth the outside pipe diameter, but not less than six inches (150 mm) and sliced under the haunches of the pipe with a shovel or other suitable tool to a height of one-half the outside pipe diameter, or to the horizontal centerline. The initial backfill shall be hand placed to a level of 12" (300 mm) over the top of the pipe and shall consist of finely divided materials free from debris, organic material and large rocks or stones.

### **Class "C" Bedding**

The pipe shall be bedded in crushed granite material or other suitable materials approved by the Authority. The bedding shall be placed on a flat trench bottom with a minimum thickness beneath the pipe of one-eighth the outside pipe diameter, but not less than six inches (150 mm) and sliced under the haunches of the pipe with a shovel or other suitable tool to a height of one-sixth the outside diameter of the pipe. The initial backfill shall be hand placed to a level of 12" (300 mm) over the top of the pipe and shall consist of finely divided materials free from debris, organic material and large rocks or stones.

### **Special Bedding for PVC Pipe**

The pipe shall be bedded in crushed granite material or other suitable materials approved by the Authority. The bedding shall be placed on a flat trench bottom with a minimum thickness beneath the pipe of one-fourth the outside pipe diameter, but not less than six inches (150 mm) and sliced under the haunches of the pipe with a shovel or other suitable tool to a height of two-thirds the outside pipe diameter. The initial backfill shall be hand placed to a level of 12" (300 mm) over the top of the pipe and shall consist of finely divided materials free from debris, organic material and large rocks or stones.

## **607. BEDDING MATERIAL**



Bedding material shall conform to ASTM D2487 standards.

**Class I**

This class includes angular, 6 to 40 mm (0.25 to 1.5 in.), graded stone, including a number of fill materials that have regional significance such as coral, slag, cinders, crushed stone, and crushed shells. Class I material provides the best material for the construction of a stable sewer pipe - soil system.

**Class II**

This class comprises coarse sands and gravels with maximum particle size of 40 mm (1.5 in.), including variously graded sands and gravels containing small percentages of fines, generally granular and non-cohesive, either wet or dry. Soil types GW, GP, SW and SP are included.

**Class III**

This class comprises fine sand and clayey gravels, including fine sands, sand - clay mixtures, and gravel - clay mixtures. Soil types GM, GC, SM and SC are included.

**Class IV**

Class IV materials require special effort for compaction, thus may be suitable for sewer pipe foundation if special care is taken during excavation to provide a uniform, undisturbed trench bottom. Use of Class IV materials for bedding, haunching or initial backfilling is not recommended. Soil types include ML, CL, MH, and CH.

**Class V**

Class V materials present special problems in providing an adequate foundation and should not be used for any part of the sewer pipe envelope. Soil types include OL, OH and PT.

**608. INSTALLATION OF SEWER PIPE**

Section 500 of these Standards, entitled "Materials for Sanitary Sewers", includes several requirements for the installation and testing of the different types of pipe materials that are approved for sanitary sewers. In addition to those material-specific requirements, the general requirements below will be followed.

Pipe and accessories shall at all times be handled with care to avoid damage. Whether moved by hand, skidways or hoists, material shall not be dropped or bumped. The interior of all pipe shall be kept free from dirt and foreign matter at all times. Each joint of pipe shall be unloaded opposite or near the place where it is to be laid in the trench.

All such material that is defective in manufacture or has been damaged in transit or after delivery shall be removed from the job site.

Sewer pipes shall be joined by "push-on" joints using elastomeric gaskets to affect the pressure seal. The ends of pipe to be joined and the gaskets shall be cleaned immediately before assembly, and the assembly shall be made as recommended by the pipe manufacturer. Lubricant used must be non-toxic and supplied or approved for use by the pipe manufacturer. Sewer pipes shall be laid in the uphill direction with the bells pointing upgrade. Any variation from this procedure shall require approval from the Authority. Pipe grades shall be obtained by use of a laser and double-checked with a surveying level and rod. Where PVC pipe is connected to DI pipe, the Contractor shall use a solid sleeve if the two pipe sizes are equal.

When pipe laying is not in progress, the open ends of installed pipe shall be plugged by approved means to prevent entrance of trench water into the line.

No special laying conditions are required for ductile iron pipe (DIP) other than haunching and soil compaction to twelve (12) inches above the spring line and any other conditions which are stipulated elsewhere in these specifications.

The following laying conditions shall be followed with PVC pipe:

PVC pipe shall be installed in accordance with the requirements of ASTM D 2321.

In any area where the pipe is below the existing ground water level, the contractor will embed PVC pipe in sand or graded gravel. By embedding PVC pipe in sand or graded gravel, no special compaction requirements will be necessary. However, the sand or gravel must extend from six inches below the pipe to twelve inches above the pipe and the material must be firmly placed under the pipe haunches. See the standard details.

When embedding PVC pipe in friable, compressible soils (E.G., silt, clay, sandy clay, silty clays, etc.), special care must be exercised to provide a uniform (undisturbed or fully compacted) trench bottom. Additionally, the backfill must be compacted to 95% Standard Proctor in six inch lifts to twelve inches above the top of the pipe.

Initial backfill shall be compacted to the densities outlined in D2321. The Authority may require random compaction tests to insure compliance with D2321. If any material tested is less than the required density, the contractor shall re-compact said material.

The Contractor shall use SDR-35 material for pipe with 0-16 feet of fill. PVC pipe cannot be used at depths exceeding 16 feet.

Deflection Limit: Vertical deflection of installed pipe shall not exceed 5 percent of the undeflected diameter as defined in Table X1.1 of ASTM D3034.

Bell holes shall be provided of sufficient size to allow ample room for making the pipe

joints properly. The bottom of the trench between bell holes shall be carefully graded so that the pipe barrel will rest on a solid foundation for its entire length as shown on the plans. Each joint shall be laid so that it will form a close concentric joint with adjoining pipe and in order to avoid sudden offsets or inequalities in the flow line.

Water shall not be allowed to run or stand in the trench before the trench has been backfilled. The Contractor at no time shall open up more trench than his available pumping facilities are able to dewater.

Any pipe which has its alignment, grade or joints disturbed after installation shall be taken up and relaid.

For force mains, the Contractor shall place a vertical piece of 2" diameter PVC pipe on top of the pipe at all bends, fittings, valves, elevation transitions and every 50' along the length of the force main for the purpose of enabling the surveyor to locate the force main for "As-Builts". The Contractor will then be responsible for removing the vertical PVC sections after the as-built locations have been verified by the Authority. All ductile iron force mains shall be encased in green polyethylene tubing.

At the point of connection to the Authority's existing sanitary sewer system, the new sanitary sewer line shall remain plugged or otherwise disconnected from the system until the new sanitary sewer lines are inspected, tested and determined to be acceptable to the Authority's Chief Inspector. The Developer will be fined for any storm water flows, mud or other construction debris that enters the Authority's system due to non-compliance with this requirement.

If the as-built capacity decreases below the approved plan capacity in excess of the acceptable percentages listed below, the pipe shall be taken up and relaid.

<u>Proposed Flow Rate</u>	<u>Acceptable Percent Decrease In Capacity</u>
0 – 400 GPM	5%
401 – 800 GPM	7.5%
>801 GPM	10%

## **609. BACKFILLING TRENCHES**

Backfill material shall consist of fine, loose earth containing sufficient but not excessive moisture content for thorough compaction. Material that is too dry for adequate compaction shall receive a prior admix of sufficient water to secure adequate moisture content. Material having excessive water content shall not be placed at any time. Backfill material shall be free of large clods, stones, vegetable matter, debris, and other objectionable material. All unsuitable excavated material and excess material must be properly disposed of in a manner that will not adversely affect the environment.

After the pipe has been laid, backfilling shall be done in two (2) distinct operations. In general, all backfill beneath, around and to a depth of twelve (12") inches above the top of the pipe shall be placed by hand in four (4") inch layers for the full width of the trench and thoroughly compacted by hand with vibratory equipment. The remainder of the backfill shall be placed in 6" layers and compacted to the top of the trench, either by pneumatic hand tamps, hydro-tamps, or other approved methods. Care shall be taken so that the pipe is not laterally displaced during backfilling operations. The backfill lifts shall be placed by an approved method in accordance with that hereinafter specified. Backfill materials shall be the excavated materials without bricks, stone, or corrosive materials.

Backfill under permanent concrete or bituminous pavement and as elsewhere specified or indicated on the plans shall be compacted graded aggregate free from large stones and containing not more than ten percent (10%) by weight of loam or clay. This backfill shall be compacted to ninety-five percent (95%) as determined by the Standard Proctor test from pipe bedding to one foot below the top of the trench, and the top one foot of the trench shall be compacted to one hundred percent (100%) as determined by the Standard Proctor test. Mechanical vibrating equipment shall be used to achieve the required compaction.

Backfill under gravel or crushed stone surfaced roadways and surface treated type bituminous roadways shall be the approved suitable excavated material placed in six (6) inch layers thoroughly compacted for the full depth and width of the trench. Backfill shall be free from large stones and contain not more than ten percent (10%) by weight of loam or clay. This backfill shall be compacted to ninety-five percent (95%) as determined by the Standard Proctor test from pipe bedding to one foot below the top of the trench, and the top one foot of the trench shall be compacted to one hundred percent (100%) as determined by the Standard Proctor test. Mechanical vibrating equipment shall be used to achieve the required compaction.

Backfill in unpaved areas shall be compacted with mechanical vibrating equipment to ninety percent (90%) as determined by the Standard Proctor Test. Backfill material from pipe bedding to ground surface by shall be excavated earth free from large stones and other debris.

Contractor shall fully restore and replace all pavement, surface structures, etc.,

removed or disturbed as part of the work to a condition equal to that before the work began. Pavement shall be replaced immediately after the backfilling is completed.

Contractors which are utilizing the roadway shoulders for construction are required to stabilize the earth shoulders every three days as a maximum time period. Also they are required to stabilize the shoulder before leaving the work area on any particular day if rain is forecast within the next 24 hours.

Where sheeting is used in connection with the work, it is in no case to be withdrawn before the trench is sufficiently filled to prevent damage to banks, road surfaces, adjacent pipes, adjacent structures or property. When the removal of sheeting endangers adjoining improvements, it will be left in place.

All costs of compaction testing shall be the responsibility of the Developer.

## **610. RAILROAD CROSSINGS**

All railroad crossings shall conform to the requirements of the American Railway Engineering Association Manual for Railway Engineering, Part 5. The Developer shall secure permission from the railroads to schedule the work so as not to interfere with the operation of the railroads. The Developer shall be held responsible for any delays or damages occurring to the railroads. The Developer will furnish the railroad with such additional insurance as may be required, cost of same to be borne by the Developer, together with the costs for flagmen, watchmen, temporary work of any nature, safety devices and any other items that may be imposed by the railroad.

## **611. HIGHWAY CROSSINGS**

The Developer shall be responsible for the coordinating and scheduling of all construction work in the State Highway right-of-way with the Georgia Department of Transportation.

Work along and across Georgia State Highway right-of-way shall conform to Georgia D.O.T. Standard Specifications for Construction of Roads and Bridges. The Developer is required to obtain all necessary permits.

Traffic control within the state of Georgia right-of-way shall comply with Section 107.09 of the State of Georgia D.O.T. Standard Construction Specifications, or Sections 104.05 and 107.07 of the U.S. Manual On Uniform Traffic Control Devices For Streets and Highways, latest editions.

## **612. STREAM CROSSINGS**

Crossing streams shall be done in compliance with the Federal, State and Local laws and permit requirements. The methods described below are subject to change due to more recent regulations implemented by the varying government agencies. The Developer is liable for knowing and complying with the most stringent regulations in force at the time of construction.

The suggested method of crossing a river, stream, creek, impoundments, or wet weather ditch is with a bore under the creek or river with a minimum of two feet (2') of cover between the lowest point in the stream and the top of outside diameter of the casing. Casings and ductile iron pipe are required for all stream crossings and shall extend a minimum of twenty feet (20') beyond the vegetative buffer (State or County buffer, whichever is wider) on each side. An open cut of the stream is allowable if no endangered species are affected and if the Developer obtains permission from the various governing agencies. If the stream is open cut, concrete collars or encasement must be provided at all joints for ductile iron pipe with less than three feet (3') of cover.

Design engineer is responsible for checking and designing against floatation.

Where streams are allowed to be open cut by variance, the construction in stream beds shall follow the following guidelines:

Construction in and around stream beds must adhere to the current regulations of the Georgia EPD, the Corps of Engineers, Cherokee County Engineering and the U.S. Department of Fish and Wildlife. The design engineer and contractor are responsible for knowing and complying with these regulations. All necessary permits and buffer variances must be acquired by the Developer prior to the final approval of the plans by the Authority. Any item published within these specifications that is in conflict with the EPD's stream bed protection regulations is hereby deemed invalid, unless the specification herein is considered more stringent by the reviewing agency.

Fording of live streams with construction equipment will not be permitted, unless specifically approved in writing. Unless, otherwise approved in writing, mechanized equipment shall not be operated in live streams except as may be required to construct temporary diversion structures, and temporary or permanent structures.

Erosion control measures shall be installed prior to performing any stream crossings. All work should be performed when stream flows are at their lowest, and all work should be performed as quickly and safely as possible. As soon as conditions permit, the stream bed shall be cleared of all false work, debris, and other obstructions placed therein or caused by the construction operations.

## **613. PLACING OF STEEL CASING PIPE**

Casing pipe shall be installed at the locations required by the Authority. Unless directed otherwise, the installation procedure shall be the dry bore method. The hole is to be mechanically bored and cased through the soil by a cutting head on a continuous auger mounted inside the casing pipe. The installation of the casing and boring of the hole shall be done simultaneously by jacking. Lengths of pipe are to be full circumference butt-welded to the preceding section installed. Excavation material will be removed and placed at the top of the working pit. Backfill material and methods of backfilling and tamping shall be as required under Section 609. Carrier pipe shall be D.I.P.

Jacks for forcing the casing pipe through the roadbed shall have a jacking head constructed in such a manner as to apply uniform pressure around the ring of the pipe. The pipe to be jacked shall be set on guides, braced together, to properly support the section of the pipe and direct it to the proper line and grade. In general, roadbed material shall be excavated just ahead of the pipe, the excavated material removed through the pipe, and the pipe then forced through the roadbed into the excavated space.

Where pipe is required to be installed under railroads, highways, streets or other facilities by jacking or boring methods, construction shall be done in a manner that will not interfere with the operation of the facility, and shall not weaken the roadbed or structure.

The use of water or other fluids in connection with the boring operation will be permitted only to the extent necessary to lubricate cuttings. Jetting will not be permitted.

The diameter of the excavation shall conform to the outside diameter and circumference of the casing pipe as closely as practicable. Any voids which develop during the installation operation shall be pressure grouted.

The pipe shall be jacked from the low or downstream end. At each end of the casing pipe the void between the carrier pipe and casing shall be sealed with brick and mortar. Any pipe damaged in jacking operations shall be removed, and replaced by the Contractor at his expense.

After the steel casing pipe has been installed, the DIP carrier pipe shall be installed in the casing pipe. Care shall be exercised at all times to protect the coating and lining of this pipe and to maintain tight, full-seated joints in the carrier pipe. The Contractor shall also take great care in setting the pipe on guides within the casing to insure that the carrier pipe stays on the correct grade without sagging. Where the carrier pipe is 24" in diameter or less, joint gaskets shall be "Field-Lok" gaskets or approved equal inside of the casing.

## **614. REPLACEMENT OF PAVEMENT**

### **General**

Contractor shall fully restore and replace all pavement, curbs, gutters, sidewalks and other surface structures removed or disturbed, to a condition that is equal to or better than the original condition in a manner satisfactory to the Authority.

Contractors which are utilizing the roadway shoulders for construction are required to stabilize the earth shoulders every three days as a maximum time period. Also they are required to stabilize the shoulder before leaving the work area on any particular day if rain is forecast within the next 24 hours.

### **Pavement Cuts**

All paved roads will be bored and cased. A bore must be attempted before consideration will be given to cutting the street.

Existing roadways shall not be open cut unless permission is granted by the Georgia D.O.T. and/or the Cherokee County Engineering Department. Submittal of an authorization letter from the D.O.T. or the CCED is required.

One lane of traffic shall be maintained open at all times. Construction work shall be limited to time between 9 A.M. and 4 P.M.

The Contractor shall furnish traffic control devices and certified personnel to direct traffic, if required.

The above requirements may be altered with the written approval of the CCRBD in extenuating circumstances.

Assuming that a road bore has been attempted and failed, or that the Developer has received permission to open cut a road, pavement replacement shall adhere to the following guidelines:

Removing and replacing pavement shall consist of removing the type of pavement and base encountered, and replacing same to its original shape, appearance and riding quality, in accordance with the detailed plans. Final asphalt patches shall match the existing pavement type but be no less than 1 1/2 inches thick. Special care shall be exercised to match existing slopes and grades for a smooth transition. Casing will be required where the installation is under any roadway. Carrier pipe shall be D.I.P.

Concrete pavement shall be replaced with pavement of a thickness equal to that removed, or 6" for driveways and 9" for roads, whichever is thicker. The concrete shall meet the specifications of the D.O.T. for concrete paving.



Where bitumastic paving is replaced, a base course of 3000 psi concrete shall be placed over the ditch line. The concrete shall be 6" thick for driveways and parking lots and 9" thick for public roads. The top of this base course shall be left with a rough float finish 1-1/2" below the surface of the existing paving. After the concrete has attained its strength, a tack coat of AC-15 or equal shall be applied at the rate of 0.25 gallons per square yard, and a plant mix asphalt course 1-1/2" thick applied over this, and finished off level with existing pavement. (9.5 mm Superpave Level B for State Roads and 12.5 mm Superpave for County Roads.)

Unless otherwise directed in writing all pavement will be removed to a width of the trench plus 12" on each side as shown on the detailed drawings.

All pavement cuts on County roads shall be made by sawing prior to excavation to eliminate uneven and ragged edges.

The Contractor shall adhere to the Georgia D.O.T. Specifications for the Installation of Safety Barricades, Section 107.09 during construction in the roadway or shoulder.

Where possible, all pipe under existing paved driveways will be either free bored or installed in casing. Free bores under driveways will be made with D.I.P.

Where sewer lines are installed in existing paved streets, the streets in which the sewer lines are installed shall receive a full width asphalt repaving in accordance with these specifications.

## **615. LOCATION AND PROTECTION OF EXISTING UNDERGROUND UTILITIES**

It is the responsibility of the Contractor to locate and protect all underground utilities and structures. No utility is to be moved or disturbed without the approval of the utility company. Any damage caused by sewer line installation to any utility or structure shall be immediately reported to the Chief Inspector of the CCWSA and repaired at the Contractor's expense.

During construction and after the sewer main is operational and throughout the one year maintenance period, the Developer will be responsible for locating all water and sewer facilities when called upon by the Utilities Protection Center or the Authority. These utilities must be marked within 72 hours of the time notified. Any water or sewer facilities cut by others will be repaired by the Developer's contractor at the Developer's expense if the lines are not located or if they are improperly located. The Developer shall provide the name and telephone number of the company providing this locate service for the Developer.

## 616. CLEAN-UP

The Contractor shall remove all unused material, excess rock and earth, and all other debris from the construction site as closely behind the work as practical. If the Contractor fails to maintain clean-up responsibilities as directed by the Authority's representative, the Authority may choose to use their own forces to do so, followed by an invoice to the Developer for the Authority's work.

All trenches shall be backfilled and tamped before the end of each days work.

Prior to requesting the "completion of sewer main construction" inspection, the Contractor shall do the following:

Remove and dispose of in an acceptable manner all shipping timbers, shipping bands, spacers, excess materials, broken material, crates, boxes and any other material brought to the job site.

Repair or replace any work, trees, lawns, shrubs, fences, flower beds, drainage culverts or other property damaged by the sewer line construction. All items damaged beyond repair shall be replaced with the same kind of material as existed prior to the damage occurring.

All easement areas shall be cleared of trees, stumps and other debris and left in a condition such that the easement can be maintained by bush-hog equipment.

All shoulders, ditches, culverts, and other areas impacted by the sewer line construction shall be at the proper grades and smooth in appearance.

All manhole covers shall be brought to grade.

## 617. GRASSING

A uniform stand of grass is required over all construction easements and sanitary sewer easements prior to the Authority's acceptance of the sewer. Grass shall be as defined and installed or constructed in conformity with the Temporary and Permanent Disturbed Area Stabilization of the **Manual For Erosion and Sediment Control In Georgia**, 2000 or most current edition. The grassing shall be maintained for by the Contractor or Developer until final acceptance of the sewer line and appurtenances by the Authority.

Grass seed shall be selected based on the type of seed suitable to the area and season of year. Refer to the **Manual For Erosion and Sediment Control In Georgia** for grass growing schedule, selection of grass seed, fertilizers, lime, inoculants, mulching, etc.

The Contractor shall provide water for irrigation from the nearest available metered source. The soil must be thoroughly wet to a depth that will insure germination of the seed. Water must be applied at a rate not causing runoff or erosion.

Growth and coverage on areas grassed shall be considered in reasonably close conformity with the intent of this requirement when a viable stand of grass covers at least 98% of the total area with no bare spots exceeding one (1) square foot and the ground surface is fully stabilized against erosion. The Contractor shall repeat all work, including plowing, fertilizing, watering, and seeding as necessary to produce a satisfactory stand.

The Contractor or Developer shall do all maintenance work necessary to keep all planted areas in satisfactory condition until the work is finally accepted. This shall include mowing, repairing washes that occur, reseeding, and water as required to produce a healthy and growing stand of grass. Mowing will be required to remove tall and obnoxious weeds before they go to seed.

#### **618. STANDARD DETAILED DRAWINGS**

Installation of sewer lines, bedding, manholes, services, force mains, etc. shall be made in accordance with the Standard Detailed Drawings in these specifications.

#### **619. CONSTRUCTION PERMITS**

The contractor shall submit one copy of the approved construction plans which have been stamped approved. The contractor shall furnish his name and address, telephone number, Certificate of Liability Insurance, and proof of his Cherokee County business license to do this type of work. He shall also furnish the name of the person in charge of the project and any subcontractors and the name and telephone number of a responsible person who can be contacted in case of emergencies during nonworking hours.

The contractor (whose name shall appear on the approved contractor's list) shall furnish his construction schedule and shall notify the Chief Inspector a minimum of four (4) days prior to doing any work. Once the contractor begins work, he shall proceed in a workmanlike manner and shall complete the work in a reasonable time without undue off days and periods of inactivity which make it hard for the Chief Inspector to keep up with his activity.

## **620. BARRICADES**

The Contractor shall provide, erect and maintain all necessary barricades, suitable and sufficient red lights, danger signals and necessary precautions for the protection of the work and the safety of the public. Streets closed to traffic shall be protected by effective barricades on which shall be placed acceptable warning signs. Barricades shall extend completely across the street which is to be closed, and shall be illuminated at night by lights not farther than (5) feet apart, and lights shall be kept burning from sunset to sunrise.

## **621. FENCES**

On sewer line extensions to the development, the Contractor shall take down fences on or crossing right-of-way for such periods of time only as are necessary to prosecute the work of clearing, grubbing, trenching, pipe laying and backfilling. Gaps made in fences shall be closed in a substantial manner at night and during any suspension of work, and, upon completion of the pipe line, fences shall be restored to as good condition as before disturbed.

## **622. RIP-RAP**

Where required, stone rip-rap shall be dumped and hand placed to form a compact layer. Stone rip-rap shall be placed to a thickness of not less than 8" and not more than 18", to the length and width shown on the plan or as directed by the Inspector. Rip Rap shall have a geotextile underliner between the soil and the stone.

## **SECTION 700 – SEWER LINE INSPECTION, TESTING AND ACCEPTANCE**

### **701. INSPECTION**

- 1.) Inspection will be done by the Cherokee County Water and Sewerage Authority. Inspections will be scheduled as received by the Authority. The Authority must be notified four (4) days prior to any construction.
- 2.) The Chief Inspector shall be notified when specific inspections are required so that the inspection time can be scheduled.
- 3.) The Contractor shall present the following when requesting a final project inspection:
  - a.) The size and length of all lines installed including services.
  - b.) A completed Project Information Form (Exhibit B). (See form at end of Section 600.)
  - c.) As-built plans and electronic data prepared in accordance with the requirements set forth in Section 604.
- 4.) In no circumstances shall any buildings and/or plumbing fixtures be connected to the line until inspected and approved by the Authority.
- 5.) Upon request, the contractor shall furnish the Inspector with appropriate copies of the manufacturer's certification that the materials to be used meet the materials requirements of these specifications. The Inspector may reject any materials not meeting specifications or any faulty or damaged materials. Any materials so rejected must be removed from the project immediately and must be prominently marked so that they can be spotted on this or any other project.
- 6.) Authorized representatives of the Cherokee County Water and Sewerage Authority, which may include appropriate county, state or federal agencies, shall have access to the site for inspection at any time.
- 7.) The Chief Inspector shall be notified by 8:30 a.m. of each workday when work is scheduled unless authorized otherwise.
- 8.) The Chief Inspector may at any time direct that he be allowed to see any foundation, bedding, pipe work, manhole or other appurtenance. If the Chief Inspector so directs, all pipe work shall be left open until the Inspector views the work. The trench may be backfilled with the approval of the Inspector if the work is not inspected by the close of

the working day. No connections to manholes, nor wyes, bends, service laterals, nor service stoppers shall be backfilled without the approval of the Inspector.

- 9.) The contractor shall complete the project and shall have cleaned up the job site prior to requesting a final project inspection. The Chief Inspector may terminate the inspection and direct further work at any time he feels that the project is not substantially complete and ready for inspection. Manholes and lines shall be clean and free of all mud and debris at the time of inspection. The Contractor shall furnish adequate personnel to open manholes and give whatever other assistance is needed by the Chief Inspector.
- 10.) The representative of the Chief Inspector will normally visually inspect all manholes and lines for conformance to the specifications and will check the measurements shown on the "As-Builts" for accuracy. The representative may perform low pressure air test to insure all lines are sealed. Any of the following tests may also be required at the discretion of the Inspector:
- Measurement of infiltration
  - Smoke test
  - Mandrel test
  - Velocity test
  - T.V. inspection
  - Compaction test
  - Ball Test
  - Force Main Pressure and Leakage Test

Any defects found by these tests must be corrected before construction of the project may proceed.

- 11.) A punch list shall be issued for corrective work if needed. However, the Chief Inspector shall not perform the contractor's work by finding all of his problems before the project is reasonably complete.

## **702. SANITARY SEWER SYSTEM TESTING**

### **1.) GENERAL**

All sanitary sewer lines, including both gravity sewers and force mains, shall be successfully tested before being eligible for acceptance by the Authority. Any of the following tests may be run at the discretion of the Chief Inspector. All sewer mains shall also be subject to the material-specific tests listed in Section 400, "Materials for Sanitary Sewers", under each type of pipe material acceptable for sanitary sewers.

## 2.) LOW PRESSURE AIR TEST

After completing backfill of a sewer line section, conduct a low pressure air test of all pipe constructed, using methods and devices acceptable to the Authority. Perform such tests using the following general procedures:

- Temporarily plug line segment between two manholes using plugs having air tight fittings through which low pressure air can be introduced into the pipe segment being tested.
- Introduce low pressure air into the test pipe segment until the internal air pressure reaches 4.5 psig above ground water pressure, if any.
- Wait at least two minutes for air temperature in the test segment to stabilize while internal air pressure remains no less than 3.5 psig above ground water pressure.
- Bleed internal air pressure to exactly 3.5 psig above ground water pressure.
- Accurately determine the elapsed time for internal pressure to drop to 2.5 psig above ground water pressure.
- The air test is acceptable if elapsed time is no less than shown by the following table:

<u>Pipe Dia.</u>	<u>Seconds Per</u>	<u>Pipe Dia.</u>	<u>Seconds Per</u>
<u>Inches</u>	<u>100 Ft. of Pipe</u>	<u>Inches</u>	<u>100 Ft. of Pipe</u>
4	11	27	77
6	17	30	85
8	23	36	102
10	28	42	119
12	34	48	136
15	43	54	153
18	51	60	170
21	60	66	187
24	68	72	204

Air leakage time is based on pipe being damp. If pipe and joints are dry, dampen line if helpful in meeting air test time requirement.

Permanently correct excessive leakage determined by air testing, and repeat operations until Inspector witnesses a successful test on each line segment; then remove nipple through manhole wall without disturbing adjacent grout. Permanently caulk resulting hole watertight.

### 3.) **MEASUREMENT OF INFILTRATION**

The contractor shall furnish an adequate number of plugs of the proper size and acceptable weirs to measure infiltration into the system.

Measurements of flow shall be performed on any lines with a visible flow of water. In no case will an infiltration rate greater than 25 gallons per inch diameter of pipe per mile of sewer per day be allowed. All visible or audible leaks must be dug up and repaired unless it is found to be in a joint and can be repaired by chemical grouting. The testing procedure shall be in accordance with ASTM C 1091 or ASTM C 969 and shall generally include the following:

- Plug the upper (inlet) end of the test section including laterals.
- At the lower (outlet) end, collect the water and measure the quantity collected within a specific time in a calibrated container after a constant flow is generated at the pipe section outlet.
- An alternate measurement method is to use a calibrated weir installed at the outlet.

### 4.) **SMOKE TEST**

Smoke tests show infiltration/exfiltration sources by blowing artificial smoke through the sewer line with a blower designed to sit on the manhole and push air through the lines so that the smoke exits the line through cracks and holes in the line and/or manholes. Sections of line are tested individually by blocking off other line sections with sandbags or line plugs. The local fire department shall be notified prior to any smoke testing.

### 5.) **MANDREL TEST**

The mandrel test shall be performed in accordance with the following procedure for testing sewer pipe for maximum allowable deflection:

- Completely flush the line making sure the pipe is clean of any mud or trash that would hinder the passage of the mandrel.
- During the final flushing of the line, attach a floating block or ball to the end of the mandrel pull rope and float the rope through the line. (A nylon ski rope is recommended).
- After the rope is threaded through the sewer line, connect the pull rope to the



mandrel and place the mandrel in the entrance of the pipe.

- Connect a second rope to the back of the mandrel. This will enable the mandrel to be retrieved if excessive deflection is encountered.
- Remove all the slack in the pull rope by gently pulling the rope at the far manhole. After the slack has been removed, place a tape marker on the rope, close to the pipe opening where the mandrel will exit. If mandrel encounters excessive deflection, the marker will provide a means of measuring the travel distance of the mandrel so that the deflected area can be located.
- Pull mandrel through the sewer line.
- An increasing resistance to pull is an indication of excessive deflection. If this occurs measure the distance from beginning marker on rope to manhole. Locate section and replace bedding or pipe if visual examination reveals damage.
- Retest until acceptable.

## 6.) **VELOCITY TEST**

On lines installed at minimum grade and at any time the Inspector suspects that a problem with flow will occur, a velocity test of the suspected section may be required.

The contractor will add sufficient water at a point upstream of the suspect section. After flow has reached a steady state, dye or some type of floating object such as a ping pong ball or fishing float will be passed through the line.

The float will be timed as it passes through the section. Any line in which a velocity of 2.0 feet per second cannot be obtained will not be acceptable.

## 7.) **T.V. INSPECTION**

All sewer lines shall be televised and a film of the inspection made before the final plat is signed and again before the final acceptance of the sewer lines. The films may be stored on VHS or DVD. Prior to televising the mains, the mains shall be flushed with water so that sags are apparent. The mains shall be televised in segments identified by the approved manhole ID numbers (See Section 604.2). The manhole numbers shall be the same as those assigned by the Authority on the stamped plans.

Any faulty pipe noted such as sagged pipes, broken pipes, bad joints, etc., will be dug up and will be corrected. Internal grouting to repair new lines will not be allowed. After correction of the discrepancies, the line will be re-televised.

## **8.) COMPACTION TEST**

All trenches shall be subject to compaction testing after backfilling and shall meet the compaction requirements. All trenches failing to meet compaction requirements shall be excavated and recompacted and retested. This process shall continue until a passing test is achieved. All costs of compaction testing shall be the responsibility of the Developer.

## **9.) BALL TEST**

Procedure for Ball Test:

- A.) Clean lines.
- B.) Place ball that is not more than 1/2" in diameter less than diameter of pipe to be tested in the end of section to be tested. Example: Ball not less than 7-1/2" in diameter for test of 8" diameter pipe.
- C.) Ball should travel freely through the section being tested.

## **10.) FORCE MAIN PRESSURE AND LEAKAGE TEST**

- A.) After all piping has been placed, the main shall be tested by the Developer's Contractor in the presence of the Chief Inspector or his designated representative and tests shall be continued until all leaks have been made tight to the satisfaction of the Authority. The Contractor shall furnish all necessary meters, pumps, gauges, bulkheads, and other materials and appliances necessary to conduct the test as herein required. Every precaution must be taken to valve-off or otherwise protect control equipment in or attached to the pipe line to prevent damage thereto.
- B.) Before applying the specified test pressure, all air shall be expelled from the pipe. If air release valves are not available at the high places, the Contractor shall make the necessary taps at points of highest elevation before the test is made and insert plugs before the test has been completed.
- C.) Prior to the pressure test, pipe laid in trenches shall be backfilled adequately to secure the pipe during the test. Any observed leakage shall require corrective measures to pipe lines and/or joints to the satisfaction of the Inspector.

D.) The Authority will furnish the necessary water for the testing of the force mains; however, any water lost through breakage of lines or unnecessary or excessive flushing of lines will be charged to the Contractor at the current residential rate. All lines shall be tested to a pressure of 200 PSI. Test duration shall be two (2) hours. However, test pressure shall not exceed pipe, valve and/or thrust-restraint design pressures. Test pressure shall not vary by more than  $\pm 5$  psi for the duration of the test which may require periodic pumping (in which case the added water will be counted as part of the leakage). The rate of leakage shall not exceed 15 gallons per 24 hours per inch diameter per mile of force main. (See Table below.)

LEAKAGE TABULATION

<u>SIZE OF PIPE</u>	<u>GALLONS/HOUR/100 FT.</u>	<u>GALLONS/DAY/100 FT.</u>
16"	.189	4.545
12"	.142	3.409
10"	.118	2.841
8"	.095	2.273
6"	.071	1.705
4"	.047	1.136
3"	.035	0.846

**Any section of the line not meeting the above test shall have the leaks found and corrected at once and re-tested until the leakage falls within the limits specified above. Leakage testing must be witnessed and approved by the Authority.**

**703. ACCEPTANCE**

Please refer to the following CCWSA Maintenance Bond/Letter of Credit Administrative Policy for the procedures related to the final approval and acceptance of water and sanitary sewer facilities:

# Cherokee County Water and Sewerage Authority Maintenance Bond/Letter of Credit Administrative Policy and Procedures

## General

- All new developments must submit to the Authority a maintenance bond or letter of credit prior to approval of the final plat for residential developments or the acceptance of the as-built drawings for all other developments.
- Once the water and sewer infrastructure is in place and approved, the Developer must submit a maintenance bond or letter of credit in a form acceptable to CCWSA staff, prior to the Authority's approval of the Final Plat or As-Built plans.
- The maintenance bond or letter of credit **amount** will be generally determined by the linear feet of water and linear feet of sewer infrastructure within the development.
- Maintenance bonds or letters of credit shall be for a period of twelve (12) months from the receipt of Final Plat approval for residential developments or acceptance of as-built drawings for all other developments.

## Approval of Infrastructure for Final Plat Recording

- 1) Upon the completion of the water and/or sewer construction, the Developer shall contact the CCWSA's Inspector requesting a final inspection of infrastructure.
- 2) If the Authority's Inspector finds, upon inspection, that all infrastructures meet the requirements of CCWSA, he/she shall provide written notice of acceptance to the Developer.
- 3) If the CCWSA's Inspector finds, upon inspection, that infrastructures do not meet the requirements of CCWSA, the Authority shall provide the Developer with written notice detailing the reasons for rejections of the infrastructure.
- 4) Once the CCWSA's Inspector finds that all infrastructures meet the requirements of CCWSA, the inspector shall require the Developer to post maintenance bond or letter of credit.
- 5) Once a maintenance bond or letter of credit has been posted, the Authority's Inspector will approve the Final Plat for residential developments or accept the as-built drawings for all other developments.
- 6) Final plat will not be signed or as-built drawings will not be accepted until a satisfactory maintenance bond or letter of credit has been posted.

### No Exceptions.

### **Maintenance Bond/Letter of Credit Amount**

- 1) The maintenance bond or letter of credit amount will be determined generally by the linear footage of water line and/or the linear footage of sewer line within the development.
- 2) Per foot amount will be determined by the CCWSA staff taking into account the current economic climate as well as the cost of materials, labor and fuel.
- 3) The minimum maintenance bond and/or letter of credit amount required for a development shall be five thousand dollars (\$5000.00) for water and five thousand dollars (\$5000.00) for sewer.

### **Approval of Water and Sewer System for Authority Acceptance**

- 1) The twelve-month maintenance period will allow the CCWSA's Inspector to assure compliance with CCWSA development specifications. The developer shall be required to contact the CCWSA's Inspector in writing at the end of the nine (9) month period to initiate the CCWSA's punch list.
- 2) The CCWSA's Inspector shall prepare a single punch list to the Developer affording it a 60-day period in which to make all necessary repairs. The Developer shall be required to contact the CCWSA's Inspector in writing at the end of the 60-day period after all punch list items have been completed. The CCWSA's Inspector shall have 30 days to make its final review for approval and shall notify the Developer in writing of the results of this inspection. An extension of the bond may be granted at the discretion of the CCWSA's General Manager. Developer shall pay for any additional inspections required by the Developers failure to complete punch list items prior to final approval.
- 3) If any punch list items are not completed by the Developer within the specified period of time or extensions the maintenance bond or letter of credit shall be utilized to pay for the full cost of the repairs. Should the amount of the maintenance bond or letter of credit be inadequate to pay for the full cost of the repairs, CCWSA shall have the authority to collect the remaining amount from the developer.

### **Official Acceptance/Release of Bond or Letter of Credit**

- 1) At the time that the work is inspected and found free from defects, the Authority's Inspector shall provide the Developer with written "Final Approval" for the acceptance of the water and sewer infrastructure.
- 2) Upon the issuance of final approval, the CCWSA shall release the Maintenance bond or letter of credit.

### **Lift Station Maintenance Bond**

- 1) All new subdivisions or commercial developments that include wastewater lift station(s) will be required to post a maintenance bond or letter of credit for each lift station.
- 2) The amount of the maintenance bond or letter of credit will be in amount as determined by CCWSA staff.
- 3) The maintenance bond or letter of credit will be for a twelve month (12) period from the date of acceptance a limited warranty deed for the fee simple ownership of the real property upon which the pump station is constructed.
- 4) The maintenance bond or letter of credit will be released following the expiration of the twelve (12) month maintenance period and upon final inspection and final approval of the lift station.
- 5) The Developer shall provide a detailed construction cost report to the CCWSA upon completion of construction of any lift station prior to the acceptance of as-built drawings.

### **704. "AS-BUILT" DRAWINGS**

At the completion of the sanitary sewer lines and when requesting the final project inspection, the Authority's G.P.S. Coordinator shall receive from the Contractor three sets of printed "As-Built" plans and electronic data prepared in accordance with the following requirements:

- 1.) Attached to the As-Builts shall be a completed Project Information Form (Exhibit B), which includes the name of the project, the project location, the Developer's name and telephone number, the Contractor's name and telephone number, the street names, the sewer main size for each street or cross-country line, the length of each sewer main by street or segment, the pipe material used for each street or segment, the cost of the sewer facilities for each street or segment, and the work start date and work completion date for each street or segment. (A copy of a blank Project Information Form is attached at the end of Section 600.)

- 2.) Three (3) sets of "As-Built" plans shall be submitted to the Authority's G.P.S. Coordinator. The plans shall show all sewer information "As-Built" in the field and any field changes made to the approved plans. In the event "As-Built" cannot be made available at the completion of the line, the General Manager may authorize the continuation of the construction; however, the final inspection cannot be conducted and the conditional approval letter cannot be written until "As-Built" are received. In the event that the designer does not perform the field staking, the contractor must furnish certification from a licensed engineer or surveyor attesting to the accuracy of all elevations, grades, manhole locations, and service locations. This certification and the certification of the engineer / land surveyor preparing the "As-Built" must be shown on the drawings. "As-built" drawings shall include a site plan, plan and profile sheets, and any supplementary drawings and shop drawings. Stationing of the sewer gravity and force main alignments, manholes and service laterals shall be required on the "As-Built" as well as the construction drawings along with the Point I.D. The "As-Built" drawings shall meet the same requirements as the construction plans for review.

As-built plans shall be submitted on 22" x 34" drawing sheets and shall be submitted concurrently in an "Autocad" drawing electronic format. The monumentation and the calculations used to reference and determine the coordinate system for locations shall be supplied at the same time that As-Built plans are submitted. As-built information for utility locations shall be shown on plans and submitted in ASCII text electronic format for each point.

Horizontal locations shall be referenced to Georgia State Plane Coordinates (West Zone feet). Vertical locations shall be shown referenced to Mean Sea Level. Reference all horizontal locations to the NAD83/94 (latest adjustment) datum and reference all vertical locations to the NAVD88 datum. All orthometric locations shall be referenced to Geoid 99/03. All points shall be verifiable by the Cherokee County Water & Sewerage Authority control network. All Horizontal and Vertical location shall have no translation, rotation or angle adjustment. All points are subject to verification by the Cherokee County Water & Sewerage Authority.

The information submitted electronically for as-builts of gravity sewer lines shall include:

- a.) Manhole ID (CCWSA Staff will assign manhole ID numbers during plan review. The manhole ID numbers shall be shown on the revised construction plans submitted for final review before the plans are stamped. (See Section 102.6.) The same ID numbers shall be used for as-builts. (See Section 604.)
- b.) Northing
- c.) Easting
- d.) Center of Manhole (Lid) Elevation
- e.) Invert (In and Out) Elevations
- f.) Each Manhole point shall include pipe(s) entering and leaving manhole. Pipe(s) size, Pipe Invert, Material, Type (i.e. Sewer line, service line or force main).

The information submitted electronically for sewer force mains shall include:

Force Mains along County or State Roads and cross country shall be located at 50' intervals (ground and top of pipe). If Force Main is within the development and maintains a constant distance behind curb and constant depth, locate at all transitions (vertical and horizontal). All fittings, tees and bends, valves, and air release valves shall also be located. All vertical locations shall be finished ground and top of pipe. The rim elevation, top of pipe and the manhole invert elevation of all air release valve manholes shall be located. The size and material of all pipes shall be recorded.

Force Main Pipe Lines, Fittings etc...

- a.) Point ID (see CCWSA staff)
- b.) Northing
- c.) Easting
- d.) Ground Elevation
- e.) Top of Pipe Elevation
- f.) Point Description/Fitting Type and Pipe Size

Air Release Valves (Manholes)

- a.) Manhole ID (CCWSA staff will assign manhole ID number during plan review. The manhole ID numbers shall be shown on the revised construction plans submitted for final review before the plans are stamped. (See Section 102.6.) The same ID numbers shall be used for As-Built. (See Section 604.)
- b.) Northing
- c.) Easting
- d.) Center of Manhole (Lid) Elevation
- e.) Invert Elevation
- f.) Top of Pipe Elevation
- g.) Each Air Release Valve Manhole point shall include Pipe Size a  
Material.

The following are specific guidelines for the preparation of the printed version of the "as-built" drawings:

- A.) Sewer "As-Built" shall be a separate plan.
- B.) No contour lines.
- C.) Approximate depth of lateral should be shown.
- D.) Any lateral that does come out at a 90 degree angle shall show its distance from property pins.
- E.) Road names shall be on plans.
- F.) All measurements of laterals should be kept between manholes and both sides shall



add up to the distance between manholes.

- G.)** The center of all manhole rims shall be located horizontally and vertically as described above.
  - H.)** All lots are to be numbered.
  - I.)** Printed "As-Builts" are to be clear and legible.
  - J.)** Profiles are to be included in all "As-Builts".
  - K.)** Roads shall be shown on all plans.
  - L.)** "As-Built" is to be in large clear print on plans.
  - M.)** Drawings sheet shall be no larger than 24" x 36".
  - N.)** Scale no larger than 1"=20', no smaller than 1"=100' for cross-country lines and 1"=50' for congested areas.
  - O.)** When a phase of a subdivision is completed, a location sketch of the entire subdivision with said phase outlined shall appear on plans.
  - P.)** Line designation shall be used for correlation between profiles and plan view.
  - Q.)** Ground water and solid rock encountered during construction will be noted on "As-Builts".
  - R.)** Force Mains shall be located as described above.
  - S.)** Sewer point I.D.'s (M.H. I.D., Force Main points, etc...) shall be on plans, electronic data and ASCII or EXCEL data file. All point I.D.'s shall correspond.
- 3.)** As-Built sanitary sewer plans for commercial, multi-family, school and industrial sites shall show the following at a minimum scale of 1" = 100':
- a.)** Location, size and elevation of all sanitary sewer lines and of any easements required.
  - b.)** Location, size and number of dwelling units and buildings.
- 4.)** The As-Builts must be printed from the Autocad files supplied to the Authority concurrently with the As-Builts. These plans shall have been corrected to show all field changes made to the approved drawings. Hand marked copies prepared by the contractor will not be accepted for "As-Builts".
- 5.)** As-Built drawings shall include the site plan, construction plan sheets, and any supplementary drawings and shop drawings. Plan of lift stations or other special features should be shown if applicable. "As-Builts" is to be stamped in large clear print on plans.
- 6.)** The Authority shall have the right to withhold water meters until the "As-Builts" have been submitted as required.
- 7.)** Final Plat and or Final Plans will not be approved or signed by the Authority until "As-Builts", easement drawing and easement agreements have been completed and submitted to the Authority.

# CHEROKEE COUNTY WATER AND SEWERAGE AUTHORITY SEWER USE REGULATIONS

Revision 1.1 April 29, 2013

(*CHEROKEE COUNTY WATER & SEWERAGE AUTHORITY INDUSTRIAL PRETREATMENT  
PROGRAM MANUAL* Section 6.)

## Section 6. SEWER USE REGULATIONS

### 6.1 GENERAL PROVISIONS

#### 6.1.1 Purpose and Policy

These regulations set forth uniform requirements for users of the sewage collection and treatment system owned and operated by the Cherokee County Water and Sewerage Authority and enable the Authority to comply with all applicable State and Federal laws, including the Clean Water Act (33 United States Code § 1251 *et seq.*) and the General Pretreatment Regulations (40 Code of Federal Regulations Part 403).

#### 6.1.2 Objectives

The objectives of these regulations are to:

- a. Prevent the introduction of pollutants into the sewage collection and treatment system that will interfere with its operation;
- b. Prevent the introduction of pollutants into the sewage collection and treatment system that will pass through the sewage collection and treatment system, inadequately treated, into receiving waters, or otherwise be incompatible with the sewage collection and treatment system;
- c. Protect sewage collection and treatment system personnel who may be affected by wastewater and biosolids in the course of their employment and the general public;
- d. Promote reuse and recycling of industrial wastewater and biosolids from the sewage collection and treatment system;
- e. Provide for fees for the equitable distribution of the cost of operation, maintenance, and improvement of the sewage collection and treatment system; and

- f. Enable the Authority to comply with its National Pollutant Discharge Elimination System permit conditions, biosolids use and disposal requirements, and any other Federal or State laws to which the Authority's sewage collection and treatment system is subject.

### **6.1.3 Application**

These regulations apply to all users of the Authority's sewage collection and treatment system. The regulations authorize the issuance of wastewater discharge permits; provide for monitoring, compliance, and enforcement activities; establish administrative review procedures; require user reporting; and provide for the setting of fees for the equitable distribution of costs resulting from the program established herein.

### **6.1.4 Administration**

Except as otherwise provided herein, the General Manager shall administer, implement, and enforce the provisions of these regulations. The General Manager may delegate to other Authority personnel any powers granted to him or duties imposed upon him.

### **6.1.5 Abbreviations**

The following abbreviations, when used in these regulations, shall have the designated meanings:

- BOD Biochemical Oxygen Demand
- CFR Code of Federal Regulations
- COD Chemical Oxygen Demand
- EPA U.S. Environmental Protection Agency
- EPD Georgia Environmental Protection Division
- gpd gallons per day
- mg/L milligrams per liter
- NPDES National Pollutant Discharge Elimination System
- RCRA Resource Conservation and Recovery Act
- SIC Standard Industrial Classification
- TSS Total Suspended Solids
- U.S.C. United States Code

### **6.1.6 Definitions**

Unless a provision explicitly states or clearly indicates otherwise, the following terms and phrases, as used in these regulations, shall have the meanings hereinafter designated.

*Act or "the Act."* The Federal Water Pollution Control Act, also known as the Clean Water Act, as amended, 33 U.S.C. § 1251 *et seq.*

*Approval Authority.* The Director of the Environmental Protection Division of the Georgia Department of Natural Resources.

*Authority.* Cherokee County Water & Sewerage Authority

*Authorized Representative of the User.*

(1) If the user is a corporation:

- (a) The president, secretary, treasurer, or a vice president of the corporation in charge of a principal business function, or any other person who performs similar policy or decision-making functions for the corporation; or
  - (b) The manager of one or more manufacturing, production, or operation facilities, if authority to sign documents has been assigned or delegated to the manager in accordance with corporate procedures.
- (2) If the user is a partnership or sole proprietorship: a general partner or proprietor, respectively.
- (3) If the user is a Federal, State, or local governmental facility: a director or highest official appointed or designated to oversee the operation and performance of the activities of the government facility, or their designee.
- (4) The individuals described in paragraphs 1 through 3, above, may designate another authorized representative if the authorization is submitted to the Authority in writing. The authorization must specify the individual or position responsible for the overall operation of the facility from which the discharge originates or the individual or position having overall responsibility for environmental matters for the company.

*Biochemical Oxygen Demand (BOD).* The quantity of oxygen utilized in the biochemical oxidation of organic matter under standard laboratory procedures for five (5) days at 20° Celsius, expressed as a concentration (e.g., mg/L).

*Bypass.* The intentional diversion of waste streams from any portion of a user's treatment facility.

*Categorical Pretreatment Standard or Categorical Standard.* Any regulation containing pollutant discharge limits promulgated by EPA in accordance with Sections 307(b) and (c) of the Act (33 U.S.C. § 1317) which apply to a specific category of users and which appear in 40 CFR Chapter I, Subchapter N, Parts 405-471.

*Chemical Oxygen Demand (COD).* A measure of the oxygen consuming capacity of both the inorganic and organic matter present in a wastewater sample, expressed as mg of oxygen consumed per milliliter of sample during a specified analytical procedure.

*Composite Sample.* A mixture of discrete, single samples combined as a function of time or flow and analyzed to characterize the nature of the wastewater.

*Dissolved Oxygen (DO).* The amount of atmospheric oxygen dissolved in water, expressed as mg/L (9.2 mg/L at 20° C, 760 mm Hg, fresh water exposed to dry air containing 20.9% O<sub>2</sub>).

*Effluent.* Wastewater discharged from a treatment facility.

*Environmental Protection Agency (EPA).* The U.S. Environmental Protection Agency.

*Environmental Protection Division (EPD).* The Georgia Environmental Protection Division. The state agency responsible for approving local Industrial Pretreatment Programs.

*Existing Source.* Any source of discharge, the construction or operation of which commenced prior to the publication by EPA of proposed categorical pretreatment standards which will be applicable to such source if the standard is thereafter promulgated in accordance with Section 307 of the Act.

*FOG.* Fats, oils, and grease used or produced in the preparation of food. FOG is generally classified into two categories: yellow grease and brown grease. Yellow grease is the inedible FOG that remains unchanged during food preparation (e.g., deep-fryer oil). Brown grease is the floatable FOG and settled solids that can be recovered from grease traps. Yellow grease can be used by the rendering industry, but brown grease is difficult to reuse.

*General Manager.* The General Manager of the sewage collection and treatment system of the Cherokee County Water & Sewerage Authority or his authorized deputy, agent or representative.

*Grab Sample.* A discrete sample collected from a waste stream without regard to flow.

*Grease-laden waste.* Effluent discharge that is produced from food processing, food preparation, or other commercial sources that contain grease, fats, and oils.

*Grease Trap or Grease Interceptor.* A device primarily used in the food industry for removal of oils, greases, and food solids from a process waste stream.

*Indirect Discharge or Discharge.* The introduction of pollutants into the sewage collection and treatment system from any non-domestic source regulated under Section 307(b), (c), or (d) of the Act.

*Industrial Customers.* Persons who, on account of their particular type of business, discharge into the sewage collection and treatment system an unusual amount or unusual type of waste which presents special problems in sewage disposal and sewage treatment.

*Industrial User or Contributor.* An industry which discharges waste waters having the characteristics of industrial wastes, as distinct from commercial wastes or domestic wastes.

*Industrial Wastewater.* Wastewater in which the solid, liquid, and gaseous wastes from industrial processes, manufacturing, trade, business, or from the development or recovery of any natural resource (as distinct from domestic or sanitary wastes) is found.

*Instantaneous Maximum Allowable Discharge Limit.* The maximum concentration of a pollutant allowed to be discharged at any time, determined from the analysis of any grab or composite sample collected, independent of the industrial flow rate and the duration of the sampling event.

*Interference.* A discharge, which alone or in conjunction with a discharge or discharges from other sources, inhibits or disrupts the sewage collection and treatment system, its treatment processes or operations or its sludge processes, use or disposal; and therefore, is a cause of a violation of the Authority's NPDES permit or of the prevention of sewage sludge use or disposal in compliance with any of the following statutory or regulatory provisions or permits issued hereunder, or any more stringent State or local regulations: Section 405 of the Act; the Solid Waste Disposal Act, including Title II commonly referred to as the Resource Conservation and Recovery Act (RCRA); any State regulations contained in any State sludge management plan prepared pursuant to Subtitle D of the Solid Waste Disposal Act; the Clean Air Act; the Toxic Substances Control Act; and the Marine Protection, Research, and Sanctuaries Act.

*Medical Waste.* Isolation wastes, infectious agents, human blood and blood products, pathological wastes, sharps, body parts, contaminated bedding, surgical wastes, potentially contaminated laboratory wastes, and dialysis wastes.

*New Source.*

(1) Any building, structure, facility, or installation from which there is (or may be) a discharge of pollutants, the construction of which commenced after the publication of proposed pretreatment standards under Section 307(c) of the Act which will be applicable to such source if such standards are thereafter promulgated in accordance with that Section, provided that:

(a) The building, structure, facility, or installation is constructed at a site at which no other source is located; or

- (b) The building, structure, facility, or installation totally replaces the process or production equipment that causes the discharge of pollutants at an existing source; or
  - (c) The production or wastewater generating processes of the building, structure, facility, or installation are substantially independent of an existing source at the same site. In determining whether these are substantially independent, factors such as the extent to which the new facility is integrated with the existing plant, and the extent to which the new facility is engaged in the same general type of activity as the existing source, should be considered.
- (2) Construction on a site at which an existing source is located results in a modification rather than a new source if the construction does not create a new building, structure, facility, or installation meeting the criteria of (1) (b) or (c) above but otherwise alters, replaces, or adds to existing process or production equipment.
- (3) Construction of a new source as defined under this paragraph has commenced if the owner or operator has:
- (a) Begun, or caused to begin, as part of a continuous onsite construction program
    - (i) any placement, assembly, or installation of facilities or equipment; or
    - (ii) significant site preparation work including clearing, excavation, or removal of existing buildings, structures, or facilities which is necessary for the placement, assembly, or installation of new source facilities or equipment; or
  - (b) Entered into a binding contractual obligation for the purchase of facilities or equipment intended for use in its operation within a reasonable time. Options to purchase or contracts that can be terminated or modified without substantial loss, and contracts for feasibility, engineering, and design studies do not constitute a contractual obligation under this paragraph.

*Non-Contact Cooling Water.* Water used for cooling that does not come into direct contact with any raw material, intermediate product, waste product, or finished product.

*NPDES Permit.* The National Pollutant Discharge Elimination Permit issued to the Authority authorizing the discharge of treated effluent to the waters of the State.

*Oil and Grease.* Substances with similar physical characteristics, including soaps, fats, oils, and any material extractable with an appropriate solvent and not volatilized during evaporation of the solvent.

*Pass Through.* A discharge which exits the sewage collection and treatment system into waters of the United States in quantities or concentrations which, alone or in conjunction with a discharge or discharges from other sources, is a cause of a violation of any requirement of the Authority's NPDES permit, including an increase in the magnitude or duration of a violation.

*Person.* Any individual, partnership, co-partnership, firm, company, corporation, association, joint stock company, trust, estate, governmental entity, or any other legal entity; or their legal representatives, agents, or assigns. This definition includes all Federal, State, and local governmental entities.

*pH.* The negative logarithm (base 10) of the concentration of the hydrogen ions. A common measure of the acidity or basicity of a solution, expressed in standard units.

*Pollutant.* Dredged spoil, solid waste, incinerator residue, filter backwash, sewage, garbage, sewage sludge, munitions, medical wastes, chemical wastes, biological materials, radioactive materials, heat, wrecked or discarded equipment, rock, sand, cellar dirt, municipal, agricultural and industrial wastes, and certain characteristics of wastewater (*e.g.*, pH, temperature, TSS, turbidity, color, BOD, COD, total Kjeldahl nitrogen, phosphorus, ammonia, oil and grease, toxicity, odor, *etc.*).

*Pretreatment.* The reduction of the amount of pollutants, the elimination of pollutants, or the alteration of the nature of pollutant properties in wastewater prior to, or in lieu of, introducing such pollutants into the sewage collection and treatment system. This reduction or alteration can be obtained by physical, chemical, or biological processes; by process changes; or by other means, except by diluting the concentration of the pollutants unless allowed by an applicable pretreatment standard.

*Pretreatment Coordinator.* The person designated by the Authority to supervise the operation of the Pretreatment Program.

*Pretreatment Requirements.* Any substantive or procedural requirement related to pretreatment imposed on a user, other than a pretreatment standard.

*Pretreatment Standards or Standards.* Pretreatment standards shall mean prohibited discharge standards, categorical pretreatment standards, and local limits.

*Prohibited Discharge Standards or Prohibited Discharges.* Absolute prohibitions against the discharge of certain substances; these prohibitions appear in Section 6.2.1 of these regulations.

*Public Sewer.* A sewer in which all owners of abutting properties have equal rights and is controlled by a public authority.

*RCRA.* Resource Conservation and Recovery Act.

*Septic Tank.* A subsurface impervious tank designed to temporarily retain sewage or similar waterborne wastes together with a subsurface system of trenches, piping, and other materials constructed to drain the clarified discharge from the tank and distribute it underground to be absorbed or filtered.

*Septic Tank Waste.* Sewage from septic tanks and other waste holding tanks such as vessels, chemical toilets, campers, trailers, *etc.*

*Sewage.* A combination of the water-carried wastes from residences, business buildings, institutions and industrial establishments, together with such ground, surface and storm waters as may be present.

*Sewage Collection and Treatment System or Publicly Owned Treatment Works (POTW).* A treatment works, as defined by Section 212 of the Act (33 U.S.C. §1292) that is owned by the Authority. Included are any devices or systems used in the collection, storage, treatment, recycling, and reclamation of sewage or industrial wastes of a liquid nature and any conveyances that convey wastewater to a treatment plant. For the purposes of these regulations, this definition also includes any sewers that convey wastewaters through the Authority's sewage collection and treatment system from persons who are by contract or agreement with the Authority or in any other way users of the Authority's sewage collection and treatment system

*Significant Industrial User (SIU).*

(1) A user subject to Categorical Pretreatment Standards; or

(2) A user that:

- (a) Discharges an average of ten thousand (10,000) gpd or more of *process* wastewater to the Authority's sewage collection and treatment system (excluding sanitary, non-contact cooling, and boiler blowdown wastewater);
- (b) Contributes a process waste stream which makes up five (5) percent or more of the average dry weather hydraulic or organic capacity of the sewage collection and treatment system; or

(c) Is designated as such by the Authority on the basis that it has a reasonable potential for adversely affecting the Authority's sewage collection and treatment system operation or for violating any pretreatment standard or requirement.

(3) Upon a finding that a user meeting the criteria in (2) above has no reasonable potential for adversely affecting the Authority's sewage collection and treatment system operation or for violating any pretreatment standard or requirement, the Authority may at any time, on its own initiative or in response to a petition received from a user, and in accordance with procedures in 40 CFR 403.8(f)(6), determine that such user should not be considered a Significant Industrial User.

*Slug Load or Slug.* Any discharge at a flow rate or concentration that could cause a violation of the prohibited discharge standards in Section 6.2.1 of these regulations.

*Standard Industrial Classification (SIC) Code.* A classification pursuant to the *Standard Industrial Classification Manual* issued by the United States Office of Management and Budget.

*Standard Methods.* Those procedures or methods established by the latest EPD-approved edition of "Standard Methods for the Examination of Water and Wastewater" as prepared, approved and published jointly by the American Public Health Association, the American Water Works Association, and the Water Environment Federation.

*Stormwater.* Any flow of water through the Authority's sewage collection and treatment system occurring during or following any form of natural precipitation and resulting from such precipitation.

*Suspended Solids.* The total suspended matter that floats on the surface of, or is suspended in, water, wastewater, or other liquid, and which is removable by laboratory filtering through the appropriate filtering system specified in Standard Methods. Suspended solids are also referred to as nonfilterable residue.

*Toxic.* Constituents of wastes that adversely affect the organisms involved in wastewater treatment.

*User or Industrial User.* A source of indirect discharge.

*Wastewater.* Liquid and water-carried industrial wastes and sewage from residential dwellings, commercial buildings, industrial and manufacturing facilities, and institutions, whether treated or untreated, which are contributed to the Authority's sewage collection and treatment system.

*Wastewater Treatment Plant or Treatment Plant.* That portion of the Authority's sewage collection and treatment system designed to provide treatment of municipal sewage and industrial waste.

*Water Meter.* Those devices, approved by the General Manager of the Cherokee County Water & Sewerage Authority for the purpose of establishing the quantity of water consumed.

*Will or Shall.* Mandatory. May is permissive.

## **6.2. GENERAL SEWER USE REQUIREMENTS**

### **6.2.1 Prohibited Discharge Standards**

1. *General Prohibitions.* No user shall introduce or cause to be introduced into the Authority's sewage collection and treatment system any pollutant or wastewater which causes pass through or interference. These general prohibitions apply to all users of the Authority's sewage collection and treatment system



whether or not they are subject to categorical pretreatment standards or any other National, State, or local pretreatment standards or requirements.

2. *Specific Prohibitions.* No user shall introduce or cause to be introduced into the Authority's sewage collection and treatment system the following pollutants, substances, or wastewater:

a. Pollutants which create a fire or explosive hazard in the Authority's sewage collection and treatment system, including, but not limited to, waste streams with a closed-cup flashpoint of less than 140° F (60° C) using the test methods specified in 40 CFR 261.21;

b. Wastewater having a pH less than 5.5 or more than 9.5, or otherwise causing corrosive structural damage to the Authority's sewage collection and treatment system or equipment;

c. Solid or viscous substances in amounts which will cause obstruction of the flow in the sewer system or the Authority's sewage collection and treatment system resulting in interference;

d. Pollutants, including oxygen-demanding pollutants (BOD, etc.), released in a discharge at a flow rate and/or pollutant concentration that, either singly or by interaction with other pollutants, will cause interference with the Authority's sewage collection and treatment system;

e. Wastewater having a temperature greater than 150° F (65° C), or which will inhibit biological activity in the treatment plant resulting in interference, but in no case wastewater which causes the temperature at the introduction into the treatment plant to exceed 104° F (40° C);

f. Petroleum oil, non-biodegradable cutting oil, or products of mineral oil origin, in amounts that will cause interference or pass through;

g. Pollutants which result in the presence of toxic gases, vapors, or fumes within the Authority's sewage collection and treatment system in a quantity that may cause acute worker health and safety problems;

h. Trucked or hauled pollutants, including septic tank and grease trap waste, except at discharge points designated by the General Manager;

i. Noxious or malodorous liquids, gases, solids, or other wastewater which, either singly or by interaction with other wastes, are sufficient to create a public nuisance or a hazard to life, or to prevent entry into the sewers for maintenance or repair;

j. Wastewater which imparts color which cannot be removed by the treatment process, such as, but not limited to, dye wastes and vegetable tanning solutions, which consequently imparts color to the treatment plant's effluent, thereby violating the Authority's NPDES permit;

k. Wastewater containing any radioactive wastes or isotopes except in compliance with applicable State or Federal regulations;

l. Stormwater, surface water, groundwater, artesian well water, roof runoff, subsurface drainage, swimming pool drainage, condensate, deionized water, non-contact cooling water, and unpolluted wastewater, unless specifically authorized by the General Manager;

m. Sludges, screenings, or other residues from the pretreatment of industrial wastes;

n. Medical wastes, except as specifically authorized by the General Manager in a wastewater discharge permit;

o. Wastewater causing, alone or in conjunction with other sources, the treatment plant's effluent to fail a toxicity test;

p. Detergents, surfactants, or other substances that may cause excessive foaming in the Authority's sewage collection and treatment system;

q. Fats, oils, or greases of animal or vegetable origin in concentrations greater 100 mg/l as determined by an approved analytical procedure for oil and grease analysis;

r. Any liquids, solids, or gases which by reason of their nature or quantity are or may be sufficient either alone or by interaction with other substances to cause fire or explosion or be injurious in any way to the Authority's sewage collection and treatment system or to the operation of the system. At no time shall two consecutive readings (15 to 30 minutes apart) on an explosion hazard meter at the point of discharge into the Authority's sewage collection and treatment system, or at any point in the Authority's sewage collection and treatment system, be more than five percent (5%) nor any single reading over ten percent (10%) of the Lower

Explosive Limit of the meter. Prohibited materials covered by this subsection include, but are not limited to, gasoline, kerosene, naphtha, benzene, fuel oil, motor oil, mineral spirits, commercial solvents, toluene, xylene, ethers, alcohols, ketones, aldehydes, peroxides, chlorates, perchlorates, bromates, carbides, and hydrides. Pollutants, substances, or wastewater prohibited by this Section shall not be processed or stored in such a manner that they could be discharged to the Authority's sewage collection and treatment system.

### **6.2.2 National Categorical Pretreatment Standards**

The categorical pretreatment standards found at 40 CFR Chapter I, Subchapter N, Parts 405-471 are hereby incorporated.

1. Where a categorical pretreatment standard is expressed only in terms of either the mass or the concentration of a pollutant in wastewater, the General Manager may impose equivalent concentration or mass limits in accordance with 40 CFR 403.6(c).

2. When wastewater subject to a categorical pretreatment standard is mixed with wastewater not regulated by the same standard, the General Manager shall impose an alternate limit using the combined waste stream formula in 40 CFR 403.6(e).

3. A user may obtain a variance from a categorical pretreatment standard if the user can prove, pursuant to the provisions in 40 CFR 403.13, that factors relating to its discharge are fundamentally different from those considered by EPA when developing the categorical pretreatment standard.

4. A user may obtain a net gross adjustment to a categorical standard in accordance with 40 CFR 403.15.

5. Upon promulgation of a national categorical pretreatment standard for a particular industrial subcategory, the national standard, if more stringent than limitations imposed under this article for

sources in that subcategory, shall immediately supersede the limitations imposed under this article. The General Manager will notify all affected industrial users of the applicable reporting requirements under 40 CFR 403.12.

### **6.2.3 Local Limits**

The table on the following page identifies the conventional, organic, and inorganic daily average pollutant limits (as of the date of issuance of these regulations) established to protect against treatment plant process interference, stream standards violations, or sludge contamination. Discharges by users of the Authority's sewage collection and treatment system are limited such that the concentrations of specific pollutants measured at the point of discharge into the collection system do not exceed concentrations specified in the table.

The Authority may enter into special agreements with industrial dischargers whereby the Authority allows higher discharge concentrations above local limits as long as the maximum headworks loading to the treatment plant for any pollutant is not exceeded.

The Authority reserves the right to alter the pollutant limits specified in Table 6.1 at any time and to add other pollutants as the Authority deems necessary. Current local and conventional pollutant limits will be on file in the office of the Authority's Industrial Pretreatment Coordinator.

<b>Table 6.1 Daily Average Local Limits</b>		
<b>Pollutant<sup>1</sup></b>	<b>Concentration (mg/L)</b>	<b>Sample Collection Method</b>
Ammonia	244	24 Hour Composite
BOD <sub>5</sub>	958	24 Hour Composite
COD	1589	24 Hour Composite
Oil and Grease	100	Grab
Phosphorous (Total)	49.24	24 Hour Composite
TKN	317	24 Hour Composite
TSS	1507	24 Hour Composite
Arsenic	0.19	24 Hour Composite
Cadmium	0.024	24 Hour Composite
Chromium III	3.26	N/A <sup>2</sup>
Chromium VI	0.22	Grab
Chromium (Total)	0.86	24 Hour Composite
Copper	0.40	24 Hour Composite
Cyanide	0.14	Grab
Lead	0.0047	24 Hour Composite
Mercury	0.0047	24 Hour Composite
Nickel	0.58	24 Hour Composite
Selenium	0.12	24 Hour Composite
Silver	0.12	24 Hour Composite
Zinc	1.28	24 Hour Composite
Bis(2-ethylhexyl)phthalate	0.01	24 Hour Composite
Chloroform	0.0093	Grab

<sup>1</sup> All concentrations for metallic substances are for the total (unfiltered) metal.  
<sup>2</sup> Chromium III is calculated by subtracting Hexavalent Chromium (Chromium VI) from Chromium (Total).

#### **6.2.4 Preliminary Treatment - Installation**

The admission into the public sewers of any water or wastes containing (a) more than two hundred and forty-four (244) parts per million of Ammonia, or (b) a five (5) day biochemical oxygen demand greater than nine hundred and fifty-eight (958) parts per million, or (c) a chemical oxygen demand greater than one thousand five hundred and eighty-nine (1589) parts per million, or (d) more than one hundred (100) parts per million of oil and grease, or (e) more than forty-nine and twenty-four hundredths (49.24) parts per million of total phosphorous, or (f) more than three hundred and seventeen (317) parts per million of total kjeldahl nitrogen or, (g) more than one thousand five hundred and seven (1507) parts per million of total suspended solids, or (h) having an average daily flow greater than ten thousand (10,000) gallons per day, shall be subject to the review and approval of the General Manager. Plans, specifications and any other pertinent information relating to proposed preliminary treatment facilities shall be submitted for approval of the General Manager and no construction of such facilities shall be commenced until said approval is obtained in writing.

#### **6.2.5 Preliminary Treatment Maintenance**

Where preliminary treatment facilities are provided for any waters or wastes, they shall be maintained continuously in satisfactory and effective operation, by the owner at his expense.

#### **6.2.6 Control Manholes**

When required by the General Manager, the owner of any property served by a building sewer carrying industrial wastes shall install a suitable control manhole in the building sewer to facilitate observation, sampling, and measurement. The manhole shall be safely located, and shall be constructed in accordance with plans approved by the General Manager. Permanently installed flow meters and flow recording devices may be required by the General Manager. The manhole shall be installed by the owner at his expense, and the owner at his expense shall maintain the same so as to be safe and accessible at all times.

#### **6.2.7 Site of Measurements, Tests and Analyses**

All measurements, tests and analyses of the characteristics of waters and wastes to which reference is to 40 CFR 136 shall be determined at the control manhole provided in Section 6.2.6, or upon suitable samples taken at such control manhole. In the event that no special manhole has been required, the control manhole shall be considered to be the nearest downstream manhole in the public sewer to the point at which the building sewer is connected.

#### **6.2.8 Authority's Right of Revision**

The Authority reserves the right to establish, by regulation or in wastewater discharge permits, more stringent standards or requirements on discharges to the Authority's sewage collection and treatment system.

#### **6.2.9 Dilution**

No user shall ever increase the use of process water, or in any way attempt to dilute a discharge, as a partial or complete substitute for adequate treatment to achieve compliance with a discharge limitation unless expressly authorized by an applicable pretreatment standard or requirement. The General Manager may impose mass limitations on users who are using dilution to meet applicable pretreatment standards or requirements, or in other cases when the imposition of mass limitations is appropriate.

## **6.3 PRETREATMENT OF WASTEWATER**

### **6.3.1 Pretreatment Facilities**

Users shall provide wastewater treatment as necessary to comply with these regulations and shall achieve compliance with all categorical pretreatment standards, local limits, and the prohibitions set out in Section 6.2.1 of these regulations within the time limitations specified by EPA, the State, or the General Manager, whichever is more stringent. Any facilities necessary for compliance shall be provided, operated, and maintained at the user's expense. Detailed plans describing such facilities and operating procedures shall be submitted to the General Manager for review, and shall be acceptable to the General Manager before such facilities are constructed. The review of such plans and operating procedures shall in no way relieve the user from the responsibility of modifying such facilities as necessary to produce a discharge acceptable to the Authority under the provisions of these regulations.

### **6.3.2 Additional Pretreatment Measures**

1. Whenever deemed necessary, the General Manager may require users to restrict their discharge during peak flow periods, designate that certain wastewater be discharged only into specific sewers, relocate and/or consolidate points of discharge, separate sewage waste streams from industrial waste streams, and such other conditions as may be necessary to protect the Authority's sewage collection and treatment system and determine the user's compliance with the requirements of these regulations.
2. The General Manager may require any person discharging into the Authority's sewage collection and treatment system to install and maintain, on their property and at their expense, a suitable storage and flow-control facility to ensure equalization of flow. A wastewater discharge permit may be issued solely for flow equalization.
3. Grease, oil, and sand interceptors shall be provided when, in the opinion of the General Manager, they are necessary for the proper handling of wastewater containing excessive amounts of grease and oil, or sand; except that such interceptors shall not be required for residential users. All interception units shall be of type and capacity approved by the General Manager and shall be so located to be easily accessible for cleaning and inspection. Such interceptors shall be inspected, cleaned, and repaired regularly, as needed, by the user at their expense.
4. Users with the potential to discharge flammable substances may be required to install and maintain an approved combustible gas detection meter.

### **6.3.3 Accidental Discharge/Slug Control Plans**

At least once every two (2) years, the General Manager shall evaluate whether each significant industrial user needs an accidental discharge/slug control plan. The General Manager may require any user to develop, submit for approval, and implement such a plan. Alternatively, the General Manager may develop such a plan for any user. An accidental discharge/slug control plan shall address, at a minimum, the following:

1. Description of discharge practices, including non-routine batch discharges;
2. Description of stored chemicals;
3. Procedures for immediately notifying the General Manager of any accidental or slug discharge, as required by Section 6.6.1 of these regulations; and
4. Procedures to prevent adverse impact from any accidental or slug discharge. Such procedures include, but are not limited to, inspection and maintenance of storage areas, handling and transfer of materials, loading and unloading operations, control of plant site runoff, worker training, building of

containment structures or equipment, measures for containing toxic organic pollutants, including solvents, and/or measures and equipment for emergency response.

#### **6.3.4 Hauled Wastewater**

1. Septic tank waste may be introduced into the Authority's wastewater treatment plants only at locations designated by the General Manager, and at such times as are established by the General Manager. Septic tank waste shall not be introduced into the Authority's sewage collection system. Such waste shall not violate Section 6.2 of these regulations or any other requirements established by the Authority. The General Manager may require septic tank waste haulers to obtain wastewater discharge permits.
2. The General Manager shall require haulers of industrial waste to obtain wastewater discharge permits. The General Manager may require generators of hauled industrial waste to obtain wastewater discharge permits. The General Manager also may prohibit the disposal of hauled industrial waste. The discharge of hauled industrial waste is subject to all other requirements of these regulations.
3. Industrial waste haulers may discharge loads only at locations designated by the General Manager. No load may be discharged without prior consent of the General Manager. The General Manager may collect samples of each hauled load to ensure compliance with applicable standards. The General Manager may require the industrial waste hauler to provide a waste analysis of any load prior to discharge.
4. Industrial waste haulers must provide a waste-tracking form for every load. This form shall include, at a minimum, the name and address of the industrial waste hauler, permit number, truck identification, names and addresses of sources of waste, and volume and characteristics of waste. The form shall identify the type of industry, known or suspected waste constituents, and whether any wastes are RCRA hazardous wastes.
5. CCWSA prohibits the discharge of grease laden waste at its wastewater treatment plants. FOG waste haulers may not discharge into the Authority's wastewater treatment plants or its sewage collection system.

### **6.4 WASTEWATER DISCHARGE PERMIT APPLICATION**

#### **6.4.1 Wastewater Analysis**

When requested by the General Manager, a user must submit information on the nature and characteristics of its wastewater within forty-five (45) days of the request. The General Manager is authorized to prepare a form for this purpose and may periodically require users to update this information.

#### **6.4.2 Wastewater Discharge Permit Requirement**

1. No significant industrial user shall discharge wastewater into the Authority's sewage collection and treatment system without first obtaining a wastewater discharge permit from the General Manager.
2. The General Manager may require other users to obtain wastewater discharge permits as necessary to carry out the purposes of these regulations.
3. Any violation of the terms and conditions of a wastewater discharge permit shall be deemed a violation of these regulations and subjects the wastewater discharge permittee to the sanctions set out in Sections 6.10 through 6.12 of these regulations. Obtaining a wastewater discharge permit does not relieve

a permittee of its obligation to comply with all Federal and State pretreatment standards or requirements or with any other requirements of Federal, State, and local law.

#### **6.4.3 Wastewater Discharge Permitting: Existing Connections.**

Any user required to obtain a discharge permit who was discharging wastewater into the Authority's sewage collection and treatment system prior to the effective date of these regulations and who wishes to continue such discharges shall within thirty (30) days of said date apply to the General Manager for a wastewater discharge permit in accordance with Section 6.4.5 of these regulations and shall not cause or allow discharges to the Authority's sewage collection and treatment system to continue for ninety (90) days of the effective date of these regulations except in accordance with the wastewater discharge permit issued by the General Manager.

#### **6.4.4 Wastewater Discharge Permitting: New Connections.**

Any user required to obtain a wastewater discharge permit who proposes to begin or recommence discharging into the Authority's sewage collection and treatment system must obtain such permit prior to the beginning or recommencing of such discharge. An application for this wastewater discharge permit must be filed at least ninety (90) days prior to the date upon which any discharge will begin or recommence.

#### **6.4.5 Wastewater Discharger Permit Application Contents**

All users required to obtain a wastewater discharge permit must submit a permit application. The General Manager may require all users to submit as part of an application the following information:

1. All information required by Section 6.6.1.2 of these regulations;
2. Description of activities, facilities, and plant processes on the premises, including a list of all raw materials and chemicals used or stored at the facility which are, or could accidentally or intentionally be, discharged to the Authority's sewage collection and treatment system;
3. Number of employees and proposed or actual hours of operation;
4. Each product produced by type, amount, process or processes, and rate of production;
5. Type and amount of raw materials processed (average and maximum per day);
6. Site plans, floor plans, mechanical and plumbing plans, and details to show all sewers, floor drains, and appurtenances by size, location, and elevation, and all points of discharge;
7. Time and duration of discharges; and
8. Any other information as may be deemed necessary by the General Manager to evaluate the wastewater discharge permit application.

A copy of the application used by that Authority is included in Appendix F. Incomplete or inaccurate applications will not be processed and will be returned to the user for revision.

#### **6.4.6 Application Signatories and Certification**

All wastewater discharge permit applications and user reports must be signed by an authorized representative of the user and contain the following certification statement:

"I certify under penalty of law that this document and all attachments were prepared under my direction or supervision in accordance with a system designed to assure that qualified personnel properly gather and evaluate the information submitted. Based on my inquiry of the person or persons who manage the system, or those persons directly responsible for gathering the information, the information submitted is, to the best of my knowledge and belief, true, accurate, and complete. I

am aware that there are significant penalties for submitting false information, including the possibility of fine and imprisonment for knowing violations.”

#### **6.4.7 Wastewater Discharge Permit Decisions**

The General Manager will evaluate the data furnished by the user and may require additional information. Within sixty (60) days of receipt of a complete wastewater discharge permit application, the General Manager will determine whether or not to issue a wastewater discharge permit. The General Manager may deny any application for a wastewater discharge permit.

### **6.5 WASTEWATER DISCHARGE PERMIT ISSUANCE PROCESS**

#### **6.5.1 Wastewater Discharge Permit Duration**

A wastewater discharge permit shall be issued for a specified time period, not to exceed five (5) years from the effective date of the permit. A wastewater discharge permit may be issued for a period less than five (5) years, at the discretion of the General Manager. Each wastewater discharge permit will indicate a specific date upon which it will expire.

#### **6.5.2 Wastewater Discharge Permit Contents**

A wastewater discharge permit (Appendix L) shall include such conditions as are deemed reasonably necessary by the General Manager to prevent pass through or interference, protect the quality of the water body receiving the treatment plant's effluent, protect worker health and safety, facilitate sludge management and disposal, and protect against damage to the Authority's sewage collection and treatment system. Appendix M summarizes the rationale used by the Authority to issue a permit.

Wastewater discharge permits must contain:

- a. A statement that indicates wastewater discharge permit duration, which in no event shall exceed five (5) years;
- b. A statement that the wastewater discharge permit is nontransferable without prior notification to the Authority in accordance with paragraph (e) of this Section, and provisions for furnishing the new owner or operator with a copy of the existing wastewater discharge permit;
- c. Effluent limits based on applicable pretreatment standards;
- d. Self-monitoring, sampling, reporting, notification, and record-keeping requirements. These requirements shall include an identification of pollutants to be monitored, sampling location, sampling frequency, and sample type based on Federal, State, and local law; and
- e. A statement of applicable civil and criminal penalties for violation of pretreatment standards and requirements, and any applicable compliance schedule. Such schedule may not extend the time for compliance beyond that required by applicable Federal, State, or local law.

Wastewater discharge permits may contain, but need not be limited to, the following conditions:

- a. Limits on the average and/or maximum rate of discharge, time of discharge, and/or requirements for flow regulation and equalization;
- b. Requirements for the installation of pretreatment technology, pollution control, or construction of appropriate containment devices, designed to reduce, eliminate, or prevent the introduction of pollutants into the treatment works;
- c. Requirements for the development and implementation of spill control plans or other special conditions including management practices necessary to adequately prevent accidental, unanticipated, or non-routine discharges;



- d. Development and implementation of waste minimization plans to reduce the amount of pollutants discharged;
- e. The unit charge or schedule of user charges and fees for the management of the wastewater discharged;
- f. Requirements for installation and maintenance of inspection and sampling facilities and equipment;
- g. A statement that compliance with the wastewater discharge permit does not relieve the permittee of responsibility for compliance with all applicable Federal and State pretreatment standards, including those which become effective during the term of the wastewater discharge permit; and
- h. Other conditions as deemed appropriate by the General Manager to ensure compliance with these regulations, and State and Federal laws, rules, and regulations.

### **6.5.3 Wastewater Discharge Permit Appeals**

The General Manager shall provide public notice of the issuance of a wastewater discharge permit. Any person, including the user, may petition the General Manager to reconsider the terms of a wastewater discharge permit within thirty (30) days of notice of its issuance.

1. Failure to submit a timely petition for review shall be deemed a waiver of administrative appeal.
2. In its petition, the appealing party must indicate the wastewater discharge permit provisions objected to, the reasons for this objection, and the alternative condition, if any, it seeks to place in the wastewater discharge permit.
3. The effectiveness of the wastewater discharge permit shall not be stayed pending the appeal.
4. If the General Manager fails to act within thirty (30) days, a request for reconsideration shall be deemed to be denied. Decisions not to reconsider a wastewater discharge permit, not to issue a wastewater discharge permit, or not to modify a wastewater discharge permit shall be considered final administrative actions for purposes of judicial review.
5. Aggrieved parties seeking judicial review of the final administrative wastewater discharge permit decision must do so by filing a complaint with the Cherokee County Superior Court.

### **6.5.4 Wastewater Discharge Permit Modification**

The General Manager may modify a wastewater discharge permit for good cause, including, but not limited to, the following reasons:

1. To incorporate any new or revised Federal, State, or local pretreatment standards or requirements;
2. To address significant alterations or additions to the user's operation, processes, or wastewater volume or character since the time of wastewater discharge permit issuance;
3. A change in the Authority's sewage collection and treatment system that requires either a temporary or permanent reduction or elimination of the authorized discharge;
4. Information indicating that the permitted discharge poses a threat to the Authority's sewage collection and treatment system, Authority personnel, or the receiving waters;
5. Violation of any terms or conditions of the wastewater discharge permit;
6. Misrepresentations or failure to fully disclose all relevant facts in the wastewater discharge permit application or in any required reporting;
7. Revision of or a grant of variance from categorical pretreatment standards pursuant to 40 CFR 403.13;
8. To correct typographical or other errors in the wastewater discharge permit; or
9. To reflect a transfer of the facility ownership or operation to a new owner or operator.

### **6.5.5 Wastewater Discharge Permit Transfer**

Wastewater discharge permits may be transferred to a new owner or operator only if the permittee gives at least sixty (60) days advance notice to the General Manager and the General Manager approves the wastewater discharge permit transfer. The notice to the General Manager must include a written certification by the new owner or operator which:

1. States that the new owner and/or operator have no immediate intent to change the facility's operations and processes;
  2. Identifies the specific date on which the transfer is to occur; and
  3. Acknowledges full responsibility for complying with the existing wastewater discharge permit.
- Failure to provide advance notice of a transfer renders the wastewater discharge permit void as of the date of facility transfer.

### **6.5.6 Wastewater Discharge Permit Revocation**

The General Manager may revoke a wastewater discharge permit for good cause, including, but not limited to, the following reasons:

1. Failure to notify the General Manager of significant changes to the wastewater prior to the changed discharge;
2. Failure to provide prior notification to the General Manager of changed conditions pursuant to Section 6.6.5 of these regulations;
3. Misrepresentation or failure to fully disclose all relevant facts in the wastewater discharge permit application;
4. Falsifying self-monitoring reports;
5. Tampering with monitoring equipment;
6. Refusing to allow the General Manager timely access to the facility premises and records;
7. Failure to meet effluent limitations;
8. Failure to pay fines;
9. Failure to pay sewer charges;
10. Failure to meet compliance schedules;
11. Failure to complete a wastewater survey or the wastewater discharge permit application;
12. Failure to provide advance notice of the transfer of business ownership of a permitted facility; or
13. Violation of any pretreatment standard or requirement, or any terms of the wastewater discharge permit or these regulations.

Wastewater discharge permits shall be void upon cessation of operations or transfer of business ownership. All wastewater discharge permits issued to a particular user are void upon the issuance of a new wastewater discharge permit to that user.

### **6.5.7 Wastewater Discharge Permit Reissuance**

A user with an expiring wastewater discharge permit shall apply for wastewater discharge permit re-issuance by submitting a complete permit application, in accordance with Section 6.4.5 of these regulations, a minimum of one hundred eighty (180) days prior to the expiration of the user's existing wastewater discharge permit.

### **6.5.8 Regulation of Waste Received from Other Jurisdictions**

1. If another municipality, or user located within another municipality, contributes wastewater to the Authority's sewage collection and treatment system, the Authority may enter into an interjurisdictional agreement with the contributing municipality.

2. Prior to entering into an agreement required by paragraph 1, above, the General Manager shall request the following information from the contributing municipality:
  - a. A description of the quality and volume of wastewater discharged to the Authority's sewage collection and treatment system by the contributing municipality;
  - b. An inventory of all users located within the contributing municipality that are discharging to the Authority's sewage collection and treatment system; and
  - c. Such other information as the General Manager may deem necessary.
  
3. An interjurisdictional agreement, as required by paragraph 1, above, shall contain the following conditions:
  - a. A requirement for the contributing municipality to adopt sewer use regulations that are at least as stringent as these regulations and local limits that are at least as stringent as those set out in Sections 3.4.1 and 3.4.2 of these regulations. The requirement shall specify that such regulations and limits must be revised as necessary to reflect changes made to the Authority's regulations or local limits;
  - b. A requirement for the contributing municipality to submit a revised user inventory on at least an annual basis;
  - c. A requirement for new significant industrial users discharging into sewers of a contributing municipality to obtain a wastewater discharge permit from the General Manager;
  - d. A provision specifying which pretreatment implementation activities, including wastewater discharge permit issuance, inspection and sampling, and enforcement, will be conducted by the contributing municipality; which of these activities will be conducted by the General Manager and which of these activities will be conducted jointly by the contributing municipality and the General Manager;
  - e. A requirement for the contributing municipality to provide the General Manager with access to all information that the contributing municipality obtains as part of its pretreatment activities;
  - f. Limits on the nature, quality, and volume of the contributing municipality's wastewater at the point where it discharges to the Authority's sewage collection and treatment system;
  - g. Requirements for monitoring the contributing municipality's discharge;
  - h. A provision ensuring the General Manager access to the facilities of users located within the contributing municipality's jurisdictional boundaries for the purpose of inspection, sampling, and any other duties deemed necessary by the General Manager; and
  - i. A provision specifying remedies available for breach of the terms of the interjurisdictional agreement.

## **6.6 REPORTING REQUIREMENTS**

### **6.6.1 Baseline Monitoring Reports**

1. Within either one hundred eighty (180) days after the effective date of a categorical pretreatment standard, or the final administrative decision on a category determination under 40 CFR 403.6(a)(4), whichever is later, existing categorical users currently discharging to or scheduled to discharge to the Authority's sewage collection and treatment system shall submit to the General Manager a report which contains the information listed in paragraph 2, below. At least ninety (90) days prior to commencement of their discharge, new sources, and sources that become categorical users subsequent to the promulgation of an applicable categorical standard, shall submit to the General Manager a report which contains the information listed in paragraph (2), below. A new source shall report the method of pretreatment it intends to use to meet applicable categorical standards. A new source also shall give estimates of its anticipated flow and quantity of pollutants to be discharged.

2. Users described above shall submit the information set forth below.
  - a. *Identifying Information.* The name and address of the facility, including the name of the operator and owner.
  - b. *Environmental Permits.* A list of any environmental control permits held by or for the facility.
  - c. *Description of Operations.* A brief description of the nature, average rate of production, and standard industrial classifications of the operation(s) carried out by such user. This description should include a schematic process diagram indicating points of discharge to the Authority's sewage collection and treatment system from the regulated processes.
  - d. *Flow Measurement.* Information showing the measured average daily and maximum daily flow, in gallons per day, to the Authority's sewage collection and treatment system from regulated process streams and other streams, as necessary, to allow use of the combined waste stream formula set out in 40 CFR 403.6(e).
  - e. *Measurement of Pollutants.*
    - (1). The categorical pretreatment standards applicable to each regulated process.
    - (2). The results of sampling and analysis identifying the nature and concentration, and/or mass, where required by the standard or by the General Manager, of regulated pollutants in the discharge from each regulated process. Instantaneous, daily maximum, and long-term average concentrations, or mass, where required, shall be reported. The sample shall be representative of daily operations and shall be analyzed in accordance with procedures set out in Section 6.6.10 of these regulations.
    - (3). Sampling must be performed in accordance with procedures set out in Section 6.6.11 of these regulations.
  - f. *Certification.* A statement, reviewed by the user's authorized representative and certified by a qualified professional, indicating whether pretreatment standards are being met on a consistent basis, and, if not, whether additional operation and maintenance (O&M) and/or additional pretreatment is required to meet the pretreatment standards and requirements.
  - g. *Compliance Schedule.* If additional pretreatment and/or O&M will be required to meet the pretreatment standards, the shortest schedule by which the user will provide such additional pretreatment and/or O&M. The completion date in this schedule shall not be later than the compliance date established for the applicable pretreatment standard. A compliance schedule pursuant to this Section must meet the requirements set out in Section 6.6.2 of these regulations.
  - h. *Signature and Certification.* All baseline monitoring reports must be signed and certified in accordance with Section 6.4.6 of these regulations.

## **6.6.2 Compliance Schedule Progress Reports**

The following conditions shall apply to the compliance schedule required by Section 6.6.1.2.g of these regulations:

1. The schedule shall contain progress increments in the form of dates for the commencement and completion of major events leading to the construction and operation of additional pretreatment required for the user to meet the applicable pretreatment standards (such events include, but are not limited to, hiring an engineer, completing preliminary and final plans, executing contracts for major components, commencing and completing construction, and beginning and conducting routine operation);
2. No increment referred to above shall exceed nine (9) months;
3. The user shall submit a progress report to the General Manager no later than fourteen (14) days following each date in the schedule and the final date of compliance including, as a minimum, whether or not it complied with the increment of progress, the reason for any delay, and, if appropriate, the steps being taken by the user to return to the established schedule; and
4. In no event shall more than nine (9) months elapse between such progress reports to the General Manager.

### **6.6.3 Reports on Compliance with Categorical Pretreatment Standard Deadline**

Within ninety (90) days following the date for final compliance with applicable categorical pretreatment standards, or in the case of a new source following commencement of the introduction of wastewater into the Authority's sewage collection and treatment system, any user subject to such pretreatment standards and requirements shall submit to the General Manager a report containing the information described in Section 6.6.1.2 of these regulations. For users subject to equivalent mass or concentration limits established in accordance with the procedures in 40 CFR 403.6(c), this report shall contain a reasonable measure of the user's long-term production rate. For all other users subject to categorical pretreatment standards expressed in terms of allowable pollutant discharge per unit of production (or other measure of operation), this report shall include the user's actual production during the appropriate sampling period. All compliance reports must be signed and certified in accordance with Section 6.4.6 of these regulations.

### **6.6.4 Periodic Compliance Reports**

1. All significant industrial users shall, at a frequency determined by the General Manager but in no case less than twice per year (in June and December), submit a report indicating the nature and concentration of pollutants in the discharge which are limited by pretreatment standards and the measured or estimated average and maximum daily flows for the reporting period. All periodic compliance reports must be signed and certified in accordance with Section 6.4.6 of these regulations.
2. All wastewater samples must be representative of the user's discharge. Wastewater monitoring and flow measurement facilities shall be properly operated, kept clean, and maintained in good working order at all times. The failure of a user to keep its monitoring facility in good working order shall not be grounds for the user to claim that sample results are unrepresentative of its discharge.
3. If a user subject to the reporting requirement in this Section monitors any pollutant more frequently than required by the General Manager, using the procedures prescribed in Section 6.6.11 of these regulations, the results of this monitoring shall be included in the report.

### **6.6.5 Reports of Changed Conditions**

1. Each user must notify the General Manager of any planned significant changes to the user's operations or system that might alter the nature, quality, or volume of its wastewater at least sixty (60) days before the change.
2. The General Manager may require the user to submit such information as may be deemed necessary to evaluate the changed condition, including the submission of a wastewater discharge permit application under Section 6.4.5 of these regulations.
3. The General Manager may issue a wastewater discharge permit under Section 6.4.7 of these regulations or modify an existing wastewater discharge permit under Section 6.5.6 of these regulations in response to changed conditions or anticipated changed conditions.
4. For purposes of this requirement, significant changes include, but are not limited to, flow increases of twenty percent (20%) or greater, and the discharge of any previously unreported pollutants.

### **6.6.6 Reports of Potential Problems**

1. In the case of any discharge, including, but not limited to, accidental discharges, discharges of a non-routine, episodic nature, a non-customary batch discharge, or a slug load, that may cause problems for the

Authority's sewage collection and treatment system, the user shall immediately telephone and notify the General Manager of the incident. This notification shall include the location of the discharge, type of waste, concentration and volume, if known, and corrective actions taken by the user.

2. Within five (5) days following such discharge, the user shall, unless waived by the General Manager, submit a detailed written report describing the cause(s) of the discharge and the measures to be taken by the user to prevent similar future occurrences. Such notification shall not relieve the user of any expense, loss, damage, or other liability that may be incurred as a result of damage to the Authority's sewage collection and treatment system, natural resources, or any other damage to person or property; nor shall such notification relieve the user of any fines, penalties, or other liability which may be imposed pursuant to these regulations.

3. A notice shall be permanently posted on the user's bulletin board or other prominent place advising employees whom to call in the event of a discharge described in paragraph 1, above. Employers shall ensure that all employees, who may cause such a discharge to occur, are advised of the emergency notification procedure.

#### **6.6.7 Reports from Unpermitted Users**

All users not required to obtain a wastewater discharge permit shall provide appropriate reports to the General Manager as the General Manager may require.

#### **6.6.8 Notice of Violation/Repeat Sampling and Reporting**

If sampling performed by a user indicates a violation, the user must notify the General Manager within twenty-four (24) hours of becoming aware of the violation. The user shall also repeat the sampling and analysis and submit the results of the repeat analysis to the General Manager within thirty (30) days after becoming aware of the violation.

#### **6.6.9 Notification of the Discharge of Hazardous Waste**

1. Any user who commences the discharge of hazardous waste shall notify the General Manager, the EPA Regional Waste Management Division Director, and State hazardous waste authorities, in writing, of any discharge into the Authority's sewage collection and treatment system of a substance which, if otherwise disposed of, would be a hazardous waste under 40 CFR Part 261. Such notification must include the name of the hazardous waste as set forth in 40 CFR Part 261, the EPA hazardous waste number, and the type of discharge (continuous, batch, or other). If the user discharges more than one hundred (100) kilograms of such waste per calendar month to the Authority's sewage collection and treatment system, the notification also shall contain the following information to the extent such information is known and readily available to the user: an identification of the hazardous constituents contained in the wastes, an estimation of the mass and concentration of such constituents in the waste stream discharged during that calendar month, and an estimation of the mass of constituents in the waste stream expected to be discharged during the following twelve (12) months. All notifications must take place no later than one hundred and eighty (180) days after the discharge commences. Any notification under this paragraph need be submitted only once for each hazardous waste discharged. However, notifications of changed conditions must be submitted under Section 6.6.5 of these regulations. The notification requirement in this Section does not apply to pollutants already reported by users subject to categorical pretreatment standards under the self-monitoring requirements of Section 6.6 of these regulations.

2. Dischargers are exempt from the requirements of paragraph (1), above, during a calendar month in which they discharge no more than fifteen (15) kilograms of hazardous wastes, unless the wastes are

acute hazardous wastes as specified in 40 CFR 261.30(d) and 261.33(e). Discharge of more than fifteen (15) kilograms of non-acute hazardous wastes in a calendar month, or of any quantity of acute hazardous wastes as specified in 40 CFR 261.30(d) and 261.33(e), requires a one-time notification. Subsequent months, during which the user discharges more than such quantities of any hazardous waste, do not require additional notification.

3. In the case of any new regulations under Section 3001 of RCRA identifying additional characteristics of hazardous waste of listing any additional substance as a hazardous waste, the user must notify the General Manager, the EPA Regional Waste Management Division Director, and State hazardous waste authorities of the discharge of such substance within ninety (90) days of the effective date of such regulations.

4. In the case of any notification made under this Section, the user shall certify that it has a program in place to reduce the volume and toxicity of hazardous wastes generated to the degree it has determined to be economically practical.

5. This provision does not create a right to discharge any substance not otherwise permitted to be discharged by these regulations, a permit issued hereunder, or any applicable Federal or State law.

#### **6.6.10 Analytical Requirements**

All pollutant analyses, including sampling techniques, submitted as part of a wastewater discharge permit application or report shall be performed in accordance with the techniques prescribed in 40 CFR Part 136, unless otherwise specified in an applicable categorical pretreatment standard. If 40 CFR Part 136 does not contain sampling or analytical techniques for the pollutant in question, sampling and analyses must be performed in accordance with procedures approved by EPA.

#### **6.6.11 Sample Collection**

1. Except as indicated in Paragraph 2, below, the user must collect wastewater samples using flow proportional composite collection techniques. In the event flow proportional sampling is not feasible, the General Manager may authorize the use of time proportional sampling or a minimum of four (4) grab samples where the user demonstrates that this will provide a representative sample of the effluent being discharged. In addition, grab samples may be required to show compliance with instantaneous discharge limits.

2. Samples for oil and grease, temperature, pH, cyanide, phenols, hexavalent chromium, sulfides, and volatile organic compounds must be obtained using grab collection techniques.

#### **6.6.12 Timing**

Written reports will be deemed to have been submitted on the date postmarked. For reports not mailed, postage prepaid, into a mail facility serviced by the United States Postal Service, the date of receipt of the report shall govern.

#### **6.6.13 Record Keeping**

Users subject to the reporting requirements of these regulations shall retain, and make available for inspection and copying, all records of information obtained pursuant to any monitoring activities required by these regulations and any additional records of information obtained pursuant to monitoring activities undertaken by the user independent of such requirements. Records shall include the date, exact place,

method, and time of sampling, and the name of the person(s) taking the samples; the dates analyses were performed; who performed the analyses; the analytical techniques or methods used; and the results of such analyses. These records shall remain available for a period of at least three (3) years. This period shall be automatically extended for the duration of any litigation concerning the user or the Authority, or where the user has been specifically notified of a longer retention period by the General Manager.

## **6.7. COMPLIANCE MONITORING**

### **6.7.1 Right of entry: Inspection and Sampling**

The General Manager shall have the right to enter the premises of any user to determine whether the user is complying with all requirements of these regulations and any wastewater discharge permit or order issued hereunder. Users shall allow the General Manager ready access to all parts of the premises for the purposes of inspection, sampling, records examination and copying, and the performance of any additional duties.

Where a user has security measures in force that require proper identification and clearance before entry into its premises, the user shall make necessary arrangements with its security guards so that, upon presentation of suitable identification, the General Manager will be permitted to enter without delay for the purposes of performing specific responsibilities.

The General Manager shall have the right to set up on the user's property, or require installation of, such devices as are necessary to conduct sampling and/or metering of the user's operations.

The General Manager may require the user to install monitoring equipment as necessary. The facility's sampling and monitoring equipment shall be maintained at all times in a safe and proper operating condition by the user at its own expense. All devices used to measure wastewater flow and quality shall be calibrated according to the manufacturer's recommendations to ensure accuracy.

Any temporary or permanent obstruction to safe and easy access to the facility to be inspected and/or sampled shall be promptly removed by the user at the written or verbal request of the General Manager and shall not be replaced. The costs of clearing such access shall be born by the user.

Unreasonable delays in allowing the General Manager access to the user's premises shall be a violation of these regulations.

### **6.7.2 Search Warrants**

If the General Manager has been refused access to a building, structure, or property, or any part thereof, and is able to demonstrate probable cause to believe that there may be a violation of these regulations, or that there is a need to inspect and/or sample as part of a routine inspection and sampling program of the Authority designed to verify compliance with these regulations or any permit or order issued hereunder, or to protect the overall public health, safety and welfare of the community, then the General Manager may seek issuance of a search warrant from the Cherokee County Superior Court.

## **6.8 Confidential Information**

Information and data on a user obtained from reports, surveys, wastewater discharge permit applications, wastewater discharge permits, and monitoring programs, and from the General Manager's inspection and sampling activities, shall be available to the public without restriction, unless the user specifically requests, and is able to demonstrate to the satisfaction of the General Manager, that the release of such



information would divulge information, processes, or methods of production entitled to protection as trade secrets under applicable State law. Any such request must be asserted at the time of submission of the information or data. When requested and demonstrated by the user furnishing a report that such information should be held confidential, the portions of a report which might disclose trade secrets or secret processes shall not be made available for inspection by the public, but shall be made available immediately upon request to governmental agencies for uses related to the NPDES program or pretreatment program, and in enforcement proceedings involving the person furnishing the report. Wastewater constituents and characteristics and other effluent data as defined by 40 CFR 2.302 will not be recognized as confidential information and will be available to the public without restriction.

## **6.9 PUBLICATION OF USERS IN SIGNIFICANT NONCOMPLIANCE**

The General Manager shall publish annually, in the largest newspaper of general circulation where the Authority is located, a list of the users that, during the previous twelve (12) months, were in significant noncompliance with applicable pretreatment standards and requirements. The term significant noncompliance shall mean:

1. Chronic violations of wastewater discharge limits, defined here as those in which sixty-six percent (66%) or more of wastewater measurements taken during a six (6) month period exceed the daily maximum limit or average limit for the same pollutant parameter by any amount;
2. Technical Review Criteria (TRC) violations, defined here as those in which thirty-three percent (33%) or more of wastewater measurements taken for each pollutant parameter during a six (6) month period equals or exceeds the product of the daily maximum limit or the average limit multiplied by the applicable criteria (1.4 for BOD, TSS, fats, oils and grease, and 1.2 for all other pollutants except pH);
3. Any other discharge violation that the General Manager believes has caused, alone or in combination with other discharges, interference or pass through;
4. Any discharge of pollutants that has caused imminent endangerment to the public, Authority personnel, or to the environment, or has resulted in the General Manager's exercise of his emergency authority to halt or prevent such a discharge;
5. Failure to meet, within ninety (90) days of the scheduled date, a compliance schedule milestone contained in a wastewater discharge permit or enforcement order for starting construction, completing construction, or attaining final compliance;
6. Failure to provide within thirty (30) days after the due date, any required reports, including baseline monitoring reports, reports on compliance with categorical pretreatment standard deadlines, periodic self-monitoring reports, and reports on compliance with compliance schedules;
7. Failure to accurately report noncompliance; or
8. Any other violation(s) that the General Manager determines will adversely affect the operation or implementation of the local pretreatment program.

## **6.10 ADMINISTRATIVE ENFORCEMENT REMEDIES**

### **6.10.1 Notification of Violation**

When the General Manager finds that a user has violated, or continues to violate, any provision of these regulations, a wastewater discharge permit or order issued hereunder, or any other pretreatment standard or requirement, the General Manager may serve upon that user a written Notice of Violation. Within ten (10) days of the receipt of this notice, an explanation of the violation and a plan for the satisfactory correction and prevention thereof, to include specific required actions, shall be submitted by the user to the General Manager. Submission of this plan in no way relieves the user of liability for any violations occurring before or after receipt of the Notice of Violation. Nothing in this Section shall limit the

authority of the General Manager to take any action, including emergency actions or any other enforcement action, without a Notice of Violation first being issued. An example Notice of Violation is included in Section 4 (Figure 4.1).

### **6.10.2 Consent Orders**

The General Manager may enter into Consent Orders, assurances of voluntary compliance, or other similar documents establishing an agreement with any user responsible for noncompliance. Such documents will include specific action to be taken by the user to correct the noncompliance within a specified time period. An example Consent Order is included in Section 4 (Figure 4.3).

### **6.10.3 Show Cause Hearing**

The General Manager may order a user who has violated, or continues to violate, any provision of these regulations, a wastewater discharge permit or order issued hereunder, or any other pretreatment standard or requirement, to appear before the General Manager and show cause why the proposed enforcement action should not be taken. Notice (Administrative Show Cause Order, Section 4, Figure 4.4) shall be served on the user specifying the time and place for the meeting, the proposed enforcement action, the reasons for such action, and a request that the user show cause why the proposed enforcement action should not be taken. The notice of the meeting shall be served personally or by registered or certified mail at least ten (10) days prior to the hearing. Such notice may be served on any authorized representative of the user. A show cause hearing shall not be a bar against, or prerequisite for, taking any other action against the user.

### **6.10.4 Compliance Orders**

When the General Manager finds that a user has violated, or continues to violate, any provision of these regulations, a wastewater discharge permit or order issued hereunder, or any other pretreatment standard or requirement, the General Manager may issue an Administrative Compliance Order (Section 4, Figure 4.5) to the user responsible for the discharge directing that the user come into compliance within a specified time. If the user does not come into compliance within the time provided, sewer service may be discontinued unless adequate treatment facilities, devices, or other related appurtenances are installed and properly operated. Compliance orders also may contain other requirements to address the noncompliance, including additional self-monitoring and management practices designed to minimize the amount of pollutants discharged to the sewer. A compliance order may not extend the deadline for compliance established for a pretreatment standard or requirement, nor does a compliance order relieve the user of liability for any violation, including any continuing violation. Issuance of a compliance order shall not be a bar against, or a prerequisite for, taking any other action against the user.

### **6.10.5 Cease and Desist Orders**

When the General Manager finds that a user has violated, or continues to violate, any provision of these regulations, a wastewater discharge permit or order issued hereunder, or any other pretreatment standard or requirement, or that the user's past violations are likely to recur, the General Manager may issue a Cease and Desist Order (Section 4, Figure 4.2) directing the user to cease and desist all such violations and directing the user to:

1. Immediately comply with all requirements; and
  2. Take such appropriate remedial or preventive action as may be needed to properly address a continuing or threatened violation, including halting operations and/or terminating the discharge.
- Issuance of a cease and desist order shall not be a bar against, or a prerequisite for, taking any other action against the user.

### **6.10.6 Administrative Fines**

1. When the General Manager finds that a user has violated, or continues to violate, any provision of these regulations, a wastewater discharge permit or order issued hereunder, or any other pretreatment standard or requirement, the General Manager may fine such user in an amount not to exceed one thousand dollars (\$1000). Such fines shall be assessed on a per-violation, per-day basis. In the case of monthly or other long-term average discharge limits, fines shall be assessed for each day during the period of violation.
2. Unpaid charges, fines, and penalties shall, after thirty (30) calendar days, be assessed an additional penalty of five percent (5%) of the unpaid balance, and interest shall accrue thereafter at a rate of one percent (1%) per month. A lien against the user's property will be sought for unpaid charges, fines, and penalties.
3. Users desiring to dispute fines must file a written request for the General Manager to reconsider the fine along with full payment of the fine amount within thirty (30) days of being notified of the fine. Where a request has merit, the General Manager may convene a hearing on the matter. In the event the user's appeal is successful, the payment, together with any interest accruing thereto, shall be returned to the user. The General Manager may add the costs of preparing administrative enforcement actions, such as notices and orders, to the fine.
4. Issuance of an administrative fine shall not be a bar against, or a prerequisite for, taking any other action against the user.

### **6.10.7 Emergency Suspensions**

The General Manager may immediately suspend a user's discharge, after informal notice to the user, whenever such suspension is necessary to stop an actual or threatened discharge that reasonably appears to present or cause an imminent or substantial endangerment to the health or welfare of persons. The General Manager may also immediately suspend a user's discharge, after notice and opportunity to respond, that threatens to interfere with the operation of the Authority's sewage collection and treatment system, or which presents, or may present, an endangerment to the environment.

Any user notified of a suspension of its discharge shall immediately stop or eliminate its contribution. In the event of a user's failure to immediately comply voluntarily with the suspension order, the General Manager may take such steps as deemed necessary, including immediate severance of the sewer connection, to prevent or minimize damage to the Authority's sewage collection and treatment system, its receiving stream, or endangerment to any individuals. The General Manager may allow the user to recommence its discharge when the user has demonstrated to the satisfaction of the General Manager that the period of endangerment has passed, unless the termination proceedings in Section 6.10.8 of these regulations are initiated against the user.

A user responsible, in whole or in part, for any discharge presenting imminent endangerment shall submit a detailed written statement, describing the causes of the harmful contribution and the measures taken to prevent any future occurrence, to the General Manager prior to the date of any show cause or termination hearing under Sections 6.10.3 or 6.10.8 of these regulations.

Nothing in this Section shall be interpreted as requiring a hearing prior to any emergency suspension under this Section.

### **6.10.8 Termination of Discharge**

In addition to the provisions in Section 6.5.6 of these regulations, any user who violates the following conditions is subject to discharge termination:

1. Violation of wastewater discharge permit conditions;
2. Failure to accurately report wastewater constituents and characteristics of the discharge;
3. Failure to report significant changes in operations or wastewater volume, constituents, and characteristics prior to discharge;
4. Refusal of reasonable access to the user's premises for the purpose of inspection, monitoring, or sampling; or
5. Violation of the pretreatment standards in Section 6.2 of these regulations.

Such user will be notified of the proposed termination of his discharge and be offered an opportunity to show cause under Section 6.10.3 of these regulations why the proposed action should not be taken. Exercise of this option by the General Manager shall not be a bar to, or a prerequisite for, taking any other action against the user.

## **6.11 JUDICIAL ENFORCEMENT REMEDIES**

### **6.11.1 Injunctive Relief**

When the General Manager finds that a user has violated, or continues to violate, any provision of these regulations, a wastewater discharge permit, or order issued hereunder, or any other pretreatment standard or requirement, the General Manager may petition the Cherokee County Superior Court for the issuance of a temporary or permanent injunction, as appropriate, which restrains or compels the specific performance of the wastewater discharge permit, order, or other requirement imposed by these regulations on activities of the user. The General Manager may also seek such other action as is appropriate for legal and/or equitable relief, including a requirement for the user to conduct environmental remediation. A petition for injunctive relief shall not be a bar against, or a prerequisite for, taking any other action against a user.

### **6.11.2 Civil Penalties**

1. A user violating, or continuing to violate, any provision of these regulations, a wastewater discharge permit, or order issued hereunder, or any other pretreatment standard or requirement shall be liable to the Authority for a maximum civil penalty of \$1,000 per violation, per day. In the case of a monthly or other long-term average discharge limit, penalties shall accrue for each day during the period of the violation.
2. The Authority may recover reasonable attorneys' fees, court costs, and other expenses associated with enforcement activities, including sampling and monitoring expenses, and the cost of any actual damages incurred by the Authority.
3. In determining the amount of civil liability, the Court shall take into account all relevant circumstances, including, but not limited to, the extent of harm caused by the violation, the magnitude and duration of the violation, any economic benefit gained through the user's violation, corrective actions by the user, the compliance history of the user, and any other factor as justice requires.
4. Filing a suit for civil penalties shall not be a bar against, or a prerequisite for, taking any other action against a user.

### **6.11.3 Criminal Prosecution**

1. A user who willfully or negligently violates any provision of these regulations, a wastewater discharge permit, or order issued hereunder, or any other pretreatment standard or requirement shall, upon conviction, be guilty of a misdemeanor, punishable as provided in the Cherokee County Code.
2. A user who willfully or negligently introduces any substance into the Authority's sewage collection and treatment system that causes personal injury or property damage shall, upon conviction, be guilty of a misdemeanor punishable as provided in the Cherokee County Code. This penalty shall be in addition to any other cause of action for personal injury or property damage available under State law.
3. A user who knowingly makes any false statements, representations, or certifications in any application, record, report, plan, or other documentation filed, or required to be maintained, pursuant to these regulations, wastewater discharge permit, or order issued hereunder, or who falsifies, tampers with, or knowingly renders inaccurate any monitoring device or method required under these regulations shall, upon conviction, be guilty of a misdemeanor punishable as provided in the Cherokee County Code.

### **6.11.4 Remedies Nonexclusive**

The remedies provided for in these regulations are not exclusive. The General Manager may take any, all, or any combination of these actions against a non-compliant user. Enforcement of pretreatment violations will generally be in accordance with the Authority's Enforcement Response Plan. However, the General Manager may take other action against any user when the circumstances warrant. Further, the General Manager is empowered to take more than one enforcement action against any non-compliant user.

## **6.12 SUPPLEMENTAL ENFORCEMENT ACTION**

### **6.12.1 Water Supply Severance**

Whenever a user has violated or continues to violate any provision of these regulations, a wastewater discharge permit, or order issued hereunder, or any other pretreatment standard or requirement, water service to the user may be severed. Service will only recommence, at the user's expense, after he has satisfactorily demonstrated his ability to comply.

## **6.13 BYPASS**

1. For the purposes of this Section,
  - a. "Bypass" means the intentional diversion of waste streams from any portion of a user's treatment facility.
  - b. "Severe property damage" means substantial physical damage to property, damage to the treatment facilities that causes them to become inoperable, or substantial and permanent loss of natural resources that can reasonably be expected to occur in the absence of a bypass. Severe property damage does not mean economic loss caused by delays in production.
2. A user may allow any bypass to occur which does not cause pretreatment standards or requirements to be violated, but only if it also is for essential maintenance to assure efficient operation. These bypasses are not subject to the provision of paragraphs 3 and 4 of this Section.
3. If a user knows in advance of the need for a bypass, he shall submit prior notice to the General Manager, at least ten (10) days before the date of the bypass, if possible.

4. A user shall submit oral notice to the General Manager of an unanticipated bypass that exceeds applicable pretreatment standards within twenty-four (24) hours from the time he becomes aware of the bypass. A written submission shall also be provided within five (5) days of the time the user becomes aware of the bypass. The written submission shall contain a description of the bypass and its cause; the duration of the bypass, including exact dates and times, and, if the bypass has not been corrected, the anticipated time it is expected to continue; and steps taken or planned to reduce, eliminate, and prevent reoccurrence of the bypass. The General Manager may waive the written report on a case-by-case basis if the oral report has been received within twenty-four (24) hours.

5. Bypass is prohibited, and the General Manager may take an enforcement action against a user for a bypass, unless:

- a. Bypass was unavoidable to prevent loss of life, personal injury, or severe property damage;
- b. There were no feasible alternatives to the bypass, such as the use of auxiliary treatment facilities, retention of untreated wastes, or maintenance during normal periods of equipment downtime. This condition is not satisfied if adequate back-up equipment should have been installed in the exercise of reasonable engineering judgment to prevent a bypass which occurred during normal periods of equipment downtime or preventive maintenance; and
- c. The user submitted notice as required under paragraph 3 of this Section.

6. The General Manager may approve an anticipated bypass, after considering its adverse effects, if the General Manager determines that it will meet the three conditions listed in paragraph 5 of this Section.

#### **6.14 DISCHARGE OF POLLUTED WATERS TO NATURAL OUTLETS OR STORM SEWERS PROHIBITED**

It is unlawful to discharge to any natural outlet or storm sewer within the county, or in any area under the jurisdiction of the county, any sanitary sewage, industrial wastes or other polluted waters, unless a permit for said discharge is first obtained from the Georgia Department of Natural Resources.

#### **6.15 SPECIAL AGREEMENTS AND ARRANGEMENTS AUTHORIZED.**

No statement in these regulations shall be construed as preventing any special agreement or arrangement between the Authority and any industrial user whereby an industrial waste of unusual strength or character may be accepted by the Authority for treatment, subject to payment by the industrial user.

#### **6.16 MISCELLANEOUS PROVISIONS**

##### **6.16.1 Pretreatment Charges and Fees**

The Authority may adopt reasonable fees for reimbursement of the costs of establishing and operating the Authority's Pretreatment Program that may include:

1. Fees for wastewater discharge permit applications and the processing of such applications;
2. Fees for monitoring, inspection, and surveillance procedures including the cost of collection and analysis of a user's discharge and review of monitoring reports submitted by users;
3. Fees for reviewing and responding to accidental discharge procedures and construction;
4. Fees for filing appeals; and
5. Other fees as the Authority may deem necessary to carry out the requirements contained herein. These fees relate solely to the matters covered by these regulations and are separate from all other fees, fines, and penalties chargeable by the Authority.

### **6.16.2 Conflict and Precedence**

These regulations, industrial wastewater discharge permits, and federal Pretreatment standards are complementary, and what is called for by one is as binding as if called for by all. In the event there are conflicts in the documents, the several documents shall take precedence in the following order:

1. Industrial Wastewater Discharge Permit
2. Federal Pretreatment Standards
3. These regulations

### **6.16.3 Industrial Wastewater Pretreatment System Operators**

Industrial wastewater pretreatment operators must comply with State of Georgia licensing requirements.

### **6.16.4 Severability**

If any provision of these regulations is invalidated by any court of competent jurisdiction, the remaining provisions shall not be affected and shall continue in full force and effect.

### **6.17 EFFECTIVE DATE**

These regulations shall be in full force and effect immediately following their adoption by the Board of Directors of the Cherokee County Water & Sewerage Authority.

**CHEROKEE COUNTY WATER AND SEWERAGE AUTHORITY  
INDUSTRIAL PRETREATMENT PROGRAM**

**APPLICATION FOR A PRETREATMENT PERMIT**  
(includes Baseline Monitoring Report Data)

To be filed by persons engaged in manufacturing, mining, or commercial operations which generate pollutants which are discharged to publicly owned treatment works and then into the waters of the State.

FOR CCWSA USE

Application

Number: \_\_\_\_\_

Date

Received: \_\_\_\_\_

YR      MO      DAY

Please fill out this form accurately and legibly and return to:

ATTN: Nate Giddens  
CCWSA Industrial Pretreatment Coordinator  
260 Colemans Bluff Dr.  
Woodstock, GA 30188

**SECTION A - GENERAL INFORMATION**

1. a. Will you be connected to the public sanitary sewer system?  
 Yes  No (if no, then do not continue with application. Sign application and submit to Cherokee County Water and Sewerage Authority).

- b. For an existing business:

Is the building presently connected to the public sanitary sewer system?

Yes:

No: Have you applied for a sanitary sewer hookup?  Yes  No

- c. For a new business:

- (i). Will you be occupying an existing vacant building?

Yes  No

- (ii). Have you applied for a building permit if a new facility will be constructed?

Yes  No

2. Does or will this facility discharge any wastewater other than from rest rooms to the Authority's sewer?

Yes If the answer to this question is "Yes", please complete the remainder of the application.

No If the answer to this question is "No", skip to Section I.



3. Facility Name: \_\_\_\_\_

a. Operator Name: \_\_\_\_\_

b. Is the operator identified in 1.a., the owner of the facility?

Yes  No

If no, provide the name and address of the operator and submit a copy of the contract and/or documents indication the operator's scope of responsibility for the facility.

\_\_\_\_\_  
\_\_\_\_\_

4. Facility Address:

Street: \_\_\_\_\_

City: \_\_\_\_\_ State: \_\_\_\_\_ Zip: \_\_\_\_\_

5. Business Mailing Address:

Street or PO Box: \_\_\_\_\_

City: \_\_\_\_\_ State: \_\_\_\_\_ Zip: \_\_\_\_\_

6. Designated signatory authority of the facility:

(Attach similar information for each authorized representative.)

Name: \_\_\_\_\_

Title: \_\_\_\_\_

Address: \_\_\_\_\_

City: \_\_\_\_\_ State: \_\_\_\_\_ Zip: \_\_\_\_\_

Phone Number: \_\_\_\_\_

7. Designated facility contact:

Name: \_\_\_\_\_

Title: \_\_\_\_\_

Phone Number: \_\_\_\_\_

**SECTION B - BUSINESS ACTIVITY**

1. If your facility employs or will be employing processes in any of the industrial categories listed below (regardless of whether they generate wastewater, waste sludge, or hazardous waste), place a check beside the category (check all that apply).

Industrial Categories	Code of Federal Regulations (CFR) Reference Number
<input type="checkbox"/> Aluminum Forming	467
<input type="checkbox"/> Asbestos Manufacturing	427
<input type="checkbox"/> Battery Manufacturing	461
<input type="checkbox"/> Canned and Preserved Fruits and Vegetables Processing	407
<input type="checkbox"/> Canned and Preserved Seafood Processing	408
<input type="checkbox"/> Carbon Black Manufacturing	458
<input type="checkbox"/> Cement Manufacturing	411
<input type="checkbox"/> Coal Mining	434
<input type="checkbox"/> Coil Coating	465

Industrial Categories	Code of Federal Regulations (CFR) Reference Number
<input type="checkbox"/> Copper Forming	468
<input type="checkbox"/> Dairy Products Processing	405
<input type="checkbox"/> Electrical and Electronic Components Manufacturing	469
<input type="checkbox"/> Electroplating	413
<input type="checkbox"/> Explosives Manufacturing	457
<input type="checkbox"/> Feedlots	412
<input type="checkbox"/> Ferroalloy Manufacturing	424
<input type="checkbox"/> Fertilizer Manufacturing	418
<input type="checkbox"/> Glass Manufacturing	426
<input type="checkbox"/> Grain Mills	406
<input type="checkbox"/> Gum and Wood Chemicals Manufacturing	454
<input type="checkbox"/> Hospital	460
<input type="checkbox"/> Ink Formulating	447
<input type="checkbox"/> Inorganic Chemicals Manufacturing	415
<input type="checkbox"/> Iron and Steel Manufacturing	420
<input type="checkbox"/> Leather Tanning and Finishing	425
<input type="checkbox"/> Meat Products	432
<input type="checkbox"/> Metal Finishing	433
<input type="checkbox"/> Metal Molding and Casting	464
<input type="checkbox"/> Mineral Mining and Processing	436
<input type="checkbox"/> Nonferrous Metals Forming and Metal Powders	471
<input type="checkbox"/> Nonferrous Metals Manufacturing	421
<input type="checkbox"/> Oil and Gas Extraction	435
<input type="checkbox"/> Ore Mining and Dressing	440
<input type="checkbox"/> Organic Chemicals Plastic and Synthetic Fibers	414
<input type="checkbox"/> Paint Formulating	446
<input type="checkbox"/> Paving and Roofing Materials	443
<input type="checkbox"/> Pesticides Chemicals	455
<input type="checkbox"/> Petroleum Refining	419
<input type="checkbox"/> Pharmaceutical Manufacturing	439
<input type="checkbox"/> Phosphate Manufacturing	422
<input type="checkbox"/> Photographic	459
<input type="checkbox"/> Plastics Molding and Forming	463
<input type="checkbox"/> Porcelain Enameling	466
<input type="checkbox"/> Pulp, Paper, and Paperboard	430
<input type="checkbox"/> Rubber Manufacturing	428
<input type="checkbox"/> Soap and Detergent Manufacturing	417

<input type="checkbox"/>	Steam Electric Power Generating	423
<input type="checkbox"/>	Sugar Processing	409
<input type="checkbox"/>	Textile Mills	410
<input type="checkbox"/>	Timber Products Processing	429
<input type="checkbox"/>	The Builders' Paper and Board Mills	431

A facility with process inclusive in the above areas may be covered by the Environmental Protection Agency's (EPA) categorical pretreatment standards. These facilities are termed "categorical users".

2. Give a brief description of all operations at this facility including primary products or services (includes principal raw materials, catalysts, and intermediates used in the process).

---



---



---

3. Indicate applicable Standard Industrial Classification (SIC) for all processes (if more than one applies, list in descending order of importance):

- a. \_\_\_\_\_
- b. \_\_\_\_\_
- c. \_\_\_\_\_
- d. \_\_\_\_\_
- e. \_\_\_\_\_

4. Product Volume:

Product (Brand Name)	Past Calendar Year Amounts Per Day (Daily Units)		Estimate This Calendar Year Amounts Per Day (Daily Units)	
	Average	Maximum	Average	Maximum
_____	_____	_____	_____	_____
_____	_____	_____	_____	_____
_____	_____	_____	_____	_____
_____	_____	_____	_____	_____
_____	_____	_____	_____	_____
_____	_____	_____	_____	_____

**SECTION C - WATER SUPPLY**

1. Water Sources (Check as many as apply):

- Private Well
- Surface Water
- Municipal Water Utility (Specify City): \_\_\_\_\_
- Cherokee County Water and Sewerage Authority
- Other (Specify): \_\_\_\_\_

2. List average water usage on premises (new facilities may estimate):

<u>Type</u>	<u>Average Usage (GPD)</u>	<u>Indicate Estimate (E) or Measured (M)</u>
a. Contact Cooling Water	_____	_____
b. Non-contact Cooling Water	_____	_____
c. Boiler Feed	_____	_____
d. Process	_____	_____
e. Sanitary	_____	_____
f. Air Pollution Control	_____	_____
g. Contained in Product	_____	_____
<u>Type</u>	<u>Average Usage (GPD)</u>	<u>Indicate Estimate (E) or Measured (M)</u>
h. Plant & Equipment Wash Down	_____	_____
i. Irrigation & Lawn Watering	_____	_____
j. Other	_____	_____
k. <b>Total of A-J</b>	_____	_____

**SECTION D - SEWER INFORMATION**

1. Name, address, and location of the publicly owned treatment works (POTW) to which you discharge:

a. Name of organization responsible for receiving wastewater:

\_\_\_\_\_

b. Facility receiving wastewater:

Name: \_\_\_\_\_

Street Address: \_\_\_\_\_

City: \_\_\_\_\_

NPDES Permit Number: \_\_\_\_\_

2. List size, descriptive location, and flow of each facility sewer which connects to the Authority's sewer system. (If more than three, attach additional information on another sheet).

<u>Sewer Size</u>	<u>Descriptive Location of Sewer Connection or Discharge Point</u>	<u>Average Flow (GPD)</u>
_____	_____	_____
_____	_____	_____
_____	_____	_____

**SECTION E - WASTEWATER DISCHARGE INFORMATION**

1. Provide the following information on wastewater flow rate.  
(New facilities may estimate).
  - a. Hours/Day Discharged (e.g., 8 hours/day):  
M \_\_\_\_\_ T \_\_\_\_\_ W \_\_\_\_\_ TH \_\_\_\_\_ F \_\_\_\_\_ SAT \_\_\_\_\_ SUN \_\_\_\_\_
  - b. Hours of Discharge (e.g., 9am to 5pm)  
M \_\_\_\_\_ T \_\_\_\_\_ W \_\_\_\_\_ TH \_\_\_\_\_ F \_\_\_\_\_ SAT \_\_\_\_\_ SUN \_\_\_\_\_
  - c. Peak Hourly Flow Rate (GPD) \_\_\_\_\_
  - d. Maximum Daily Flow Rate (GPD) \_\_\_\_\_
  - e. Annual Daily Average (GPD) \_\_\_\_\_
  
2. If batch discharge occurs or will occur, indicate:  
(New facilities may estimate).
  - a. Number of batch discharges: \_\_\_\_\_ per day
  - b. Average discharge per batch: \_\_\_\_\_ (GPD)
  - c. Time of batch discharges: \_\_\_\_\_ at \_\_\_\_\_  
(days of week) (hours of day)
  - d. Flow rate: \_\_\_\_\_ gallons/minute
  - e. Percent of total discharge: \_\_\_\_\_
  
3. Schematic Flow Diagram - For each major activity in which wastewater is or will be generated, draw a diagram of the flow of materials, products, water, and wastewater from the start of the activity to its completion, showing all processes. Indicate which processes use water and which generate waste streams. Include the average daily volume and maximum daily volume of each waste stream [new facilities may estimate]. If estimates are used for flow data this must be indicated. Number each unit process having wastewater discharges to the community sewer. Use these numbers when showing these unit processes in the building layout in Section H.

Facilities that checked activities in question 1 of Section B are considered Categorical Industrial Users and should skip to question 5.

4. For Non-Categorical Users Only: List average wastewater discharge, maximum discharge, and type of discharge (batch, continuous, or both), for each of your processes or proposed processes. Include the reference number from the schematic flow diagram that corresponds to each process. [New facilities should provide estimates for each discharge].

<u>No.</u>	<u>Process Description</u>	<u>Average Flow (GPD)</u>	<u>Maximum Flow (GPD)</u>	<u>Type of Discharge (batch, continuous, none)</u>
_____	_____	_____	_____	_____
_____	_____	_____	_____	_____
_____	_____	_____	_____	_____
_____	_____	_____	_____	_____
_____	_____	_____	_____	_____

**ANSWER QUESTIONS 5 & 6 ONLY IF YOU ARE SUBJECT TO CATEGORICAL PRETREATMENT STANDARDS**

5. For Categorical Users: provide the wastewater discharge flows for each of your processes or proposed processes. Include the reference number from the schematic flow diagram that corresponds to each process. [New facilities should provide estimates for each discharge].

<u>No.</u>	<u>Regulated Process</u>	<u>Average Flow (GPD)</u>	<u>Maximum Flow (GPD)</u>	<u>Type of Discharge (batch, continuous, none)</u>
_____	_____	_____	_____	_____
_____	_____	_____	_____	_____
_____	_____	_____	_____	_____
_____	_____	_____	_____	_____
_____	_____	_____	_____	_____

<u>No.</u>	<u>Unregulated Process</u>	<u>Average Flow (GPD)</u>	<u>Maximum Flow (GPD)</u>	<u>Type of Discharge (batch, continuous, none)</u>
_____	_____	_____	_____	_____
_____	_____	_____	_____	_____
_____	_____	_____	_____	_____
_____	_____	_____	_____	_____
_____	_____	_____	_____	_____

<u>No.</u>	<u>Dilution</u>	<u>Average Flow (GPD)</u>	<u>Maximum Flow (GPD)</u>	<u>Type of Discharge (batch, continuous, none)</u>
_____	_____	_____	_____	_____
_____	_____	_____	_____	_____
_____	_____	_____	_____	_____
_____	_____	_____	_____	_____
_____	_____	_____	_____	_____

6. For Categorical Users Subject to Total Toxic Organic (TTO) Requirements:

Provide the following (TTO) information:

a. Does (or will) this facility use any of the toxic organics that are listed under the TTO standard of the applicable categorical pretreatment standards published by EPA?

Yes

No

b. Has baseline monitoring report (BMR) been submitted which contains TTO information?

Yes

No

c. Has a toxic organics management plan (TOMP) been developed?

Yes

No

7. Do you have, or plan to have, automatic sampling equipment or continuous wastewater flow metering equipment at this facility?

Current: Flow Metering  Yes  No  N/A

Sampling Equipment  Yes  No  N/A

Planned: Flow Metering  Yes  No  N/A

Sampling Equipment  Yes  No  N/A

If so, please indicate the present or future location of this equipment on the schematic flow diagram and describe the equipment below:

---

---

If flow metering equipment is not installed, will water use records or other method be used and be representative of discharged flow? Explain.

---

---

8. Are any process changes or expansions planned during the next three years that could alter wastewater volumes or characteristics? Consider production processes as well as air or water pollution treatment processes that may affect the discharge.

No

Yes, then briefly describe these changes and their effects on the wastewater volume and characteristics:  
(Attach additional sheets if needed.)

---

9. Are any materials or water reclamation systems in use or planned?

No

Yes, then briefly describe recovery process, substance recovered, percent recovered, and the concentration in the spent solution. Submit a flow diagram for each process: (Attach additional sheets if needed.)

---

---

10. Are any other waste minimization measures used or planned?

No

Yes, then briefly describe measures:

---

---

**SECTION F - CHARACTERISTICS OF DISCHARGE (refer to 40 CFR Part 403.12(b) for baseline monitoring report requirements).**

1. DATA: Report organics and pesticides as ug/L; conventional pollutants and metals as mg/L; mass as lbs/day. All other units have been specified.

All current industrial users are required to submit monitoring data on all pollutants that are subject to categorical standards. Use the tables provided in this section to report the analytical results. **DO NOT LEAVE BLANKS.** For all other (non-regulated) pollutants, indicate whether the pollutant is known to be present (P), suspected to be present (S), or known not to be present (O), by placing the appropriate letter in the concentration column under average of analyses. If data is available for non-regulated pollutants, please include. Indicate on either the top of each table, or on a separate sheet, if necessary, the time, date, and place of sampling, the methods of analysis, the type of sample (i.e., flow proportional composite samples, time proportional composite samples, or grab samples) and the number of representative samples taken. Be sure methods conform to 40 CFR Part 136; if they do not, indicate what method was used. A certification statement should also be provided on the table or additional sheet if necessary that such sampling and analysis are representative of normal work cycles and expected pollutant discharges to the POTW. A copy of a pollutant scan can be attached in lieu of completing the tables provided that all requested information is included on the scan.

New dischargers should use the table to indicate what pollutants will be present or are suspected to be present in proposed waste streams by placing P (expected to be present), S (may be present), or O (will not be present) in the concentration column under average of analyses. If the industry is not yet in operation, the levels of the regulated pollutants and process flows should be estimated and reported.

When analyzing for pollutants listed in Georgia's **Rules and Regulations for Water Quality Control**, The applicant should ensure that the pollutants are at least analyzed down to the detection limits as specified in Attachment No. 1. If detection levels are not applicable for specific pollutants, so indicate by placing N/A under the column detection level used.



**TABLE A - POLLUTANT SPECIFIC RESULTS**

Pollutant	Detection Level Used	Maximum Daily Value		Average of Analyses		Number of Analyses		Units	
		Conc.	Mass	Conc.	Mass	Conc.	Mass	Conc.	Mass
Acenaphthene									
Acrolein									
Acrylonitrile									
Benzene									
Benzidene									
Carbon tetrachloride									
Chlorobenzene									
1,2,4-Trichlorobenzene									
Hexachlorobenzene									
1,2-Dichloroethane									
1,1,1-Trichloroethane									
Chloroethane									
Bis(2-chloroethyl) ether									
2-Chloroethyl vinyl ether									
2-Chloronaphthalene									
2,4,6-Trichlorophenol									
Parachlorometa cresol									
Chloroform									
2-Chlorophenol									
1,2-Dichlorobenzene									
1,3-Dichlorobenzene									
1,4-Dichlorobenzene									
3,3-Dichlorobenzidene									
1,1-Dichloroethylene									
1,2-Trans-dichloroethylene									
2,4-Dichlorophenol									
1,2-Dichloropropane									
1,2-Dichloropropylene									
1,3-Dichloropropylene (Cis)									
1,3-Dichloropropylene (Trans)									

Pollutant	Detection Level Used	Maximum Daily Value		Average of Analyses		Number of Analyses		Units	
		Conc.	Mass	Conc.	Mass	Conc.	Mass	Conc.	Mass
2-Methyl-4,6-Dinitrophenol									
3-Methyl-4-Chlorophenol									
2,4-Dimethylphenol									
2,4-Dinitrotoluene									
2,6-Dinitrotoluene									
1,2-Diphenylhydrazine									
Ethylbenzene									
Fluoranthene									
4-Chlorophenyl phenyl ether									
4-Bromophenyl phenyl ether									
Bis(2-chloroisopropyl) ether									
Bis(2-chloroethoxy) methane									
Methylene chloride									
Methyl chloride									
Methyl bromide									
Bromoform									
Dichlorobromomethane									
Chlorodibromomethane									
Hexachlorobutadiene									
Hexachlorocyclopentadiene									
Isophorone									
Naphthalene									
Nitrobenzene									
Nitrophenol									
2-Nitrophenol									
4-Nitrophenol									
2,4-Dinitr									
4,6-Dinitro-o-cresol									
N-nitrosodimethylamine									
N-nitrosodiphenylamine									
N-nitrosodi-n-propyla									
Pentachlorophenol									
Phenol									
Bis(2-ethylhexyl) phthalate									

Butyl benzyl phthalate

Pollutant	Detection Level Used	Maximum Daily Value		Average of Analyses		Number of Analyses	Units	
		Conc.	Mass	Conc.	Mass		Conc.	Mass
Di-n-butyl phthalate								
Di-n-octyl phthalate								
Diethyl phthalate								
Dimethyl phthalate								
Benzo(a)anthracene								
Benzo(a)pyrene								
3,4-benzofluoranthene								
Benzo(k)fluoranthene								
Chrysene								
Acenaphthylene								
Anthracene								
Benzo(ghi)perylene								
Fluorene								
Phenanthrene								
Dibenzo(a,h)anthracene								
Indeno(1,2,3-cd)pyrene								
Pyrene								
Tetrachloroethylene								
Toluene								
Trichloroethylene								
Vinyl chloride								
Aldrin								
Dieldrin								
Chlordane								
4,4'-DDT								
4,4'-DDE								
4,4'-DDD								
Alpha-endosulfan								
Beta-endosulfan sulfate								
Endrin								
Endrin aldehyde								
Heptachlor								

800-40

Heptachlor epoxide  
a-BHC-Alpha

Pollutant	Detection Level Used	Maximum Daily Value	Average of Analyses	Number of Analyses	Units
-----------	----------------------	---------------------	---------------------	--------------------	-------

		Conc.	Mass	Conc.	Mass		Conc.	Mass
b-BHC-Beta								
d-BHC-Delta								
PCB-1242								
PCB-1254								
PCB-1221								
PCB-1232								
PCB-1248								
PCB-1260								
PCB-1016								
Toxaphene (TCDD)								
Asbestos								
Acidity mg(CaCO <sub>3</sub> )/L								
Alkalinity mg(CaCO <sub>3</sub> )/L								
Fecal Coliform Bacteria (#/100ml)								
Chloride								
Chlorine								
Fluoride								
Hardness mg(CaCO <sub>3</sub> )/L								
Magnesium								
NH <sub>3</sub> -N								
TOC								
Kjeidahl N								
Nitrate N								
Nitrite N								
Organic N								
Orthophosphate P								
Lindane [Hexachlorocyclohexane]				800-41				

(g-BHC-Gamma)]

Sodium

Pollutant	Detection Level Used	Maximum Daily Value	Average of Analyses	Number of Analyses	Units
-----------	----------------------	---------------------	---------------------	--------------------	-------

	Conc.	Mass	Conc.	Mass	Conc.	Mass
Specific Conductivity $\mu$ mhos/cm						
Sulfate (SO4)						
Sulfide						
Sulfite (SO3)						
Antimony						
Arsenic						
Barium						
Beryllium						
Cadmium						
Chromium (Total)						
Chromium VI						
Copper						
Cyanide						
Lead						
Mercury						
Nickel						
Selenium						
Silver						
Thallium						
Zinc						
Methoxyxhlor						
2,4-Dichlorophenoxy propionic acid (TP Silvex)						

**TABLE B - PROHIBITED POLLUTANTS**

Complete this table by checking the appropriate column and providing analytical results where indicated (P = known to be present, S = suspected to be present, O = known not to be present):

<u>Pollutant</u>	<u>P</u>	<u>S</u>	<u>O</u>
1. Materials that may create a fire or explosion hazard, including waste streams with a closed cup flash point of less than 140°F or 60°C using test methods in 40 CFR Part 261.21.	_____	_____	_____
Flash point (°F or °C)	_____		
2. Corrosive type materials pH <5 or pH >9	_____	_____	_____
pH (std. units)	_____		
3. Solid or viscous pollutants in amounts which could cause flow obstruction or interference with POTW operation	_____	_____	_____
4. Discharge of any pollutant (including BOD <sub>5</sub> , Suspended solids, COD, etc.) in volume or strength to cause POTW unit process upset or NPDES permit violations.	_____	_____	_____
BOD <sub>5</sub> (mg/L)	_____		
COD (mg/L)	_____		
Suspended solids (mg/L)	_____		
Oil and Grease (mg/L)	_____		
5. Heated discharges in excess of 104°F or 40°C	_____	_____	_____
Temperature (°F or °C)	_____		

TABLE B (continued)

<u>Pollutant</u>	<u>P</u>	<u>S</u>	<u>Q</u>
6. Petroleum oil, nonbiodegradable cutting oil or products of mineral oil origin that cause POTW upsets or permit violations	_____	_____	_____
7. Pollutants which result in the presence of toxic gases, vapors or fumes in a quantity that may cause acute worker health and safety problems.	_____	_____	_____
8. Any trucked or hauled pollutants to discharge points on the POTW system.	_____	_____	_____

**2. HAZARDOUS WASTES DISCHARGED TO A POTW SEWER SYSTEM** (see 40 CFR Part 403.12(p) for requirements of hazardous waste notification):

a. Do you now discharge listed or characteristic hazardous wastes as specified in 40 CFR Part 261 to a POTW sanitary sewer system?

NO

YES (if the answer is "YES" complete the following).

(i) Name of the hazardous waste as set forth in 40 CFR Part 261.

---



---

(ii) EPA hazardous waste number

---



---

(iii) Type of discharge to the sewer (continuous, batch, or other)

---

(iv) A certification should be provided below that you have a program in place to reduce the volume and toxicity of hazardous wastes generated to the extent determined to be economically practical.

---

---

---

---

(v) Describe the program components:

---

---

---

---

b. Do you discharge more than 100 kilograms of hazardous waste per calendar month to the POTW sewer?

- No  
 Yes (if the answer is "Yes" report the following).

(i) An identification of the hazardous constituents contained in the hazardous waste as specified in 40 CFR Part 261.

---

---

---

(ii) An estimation of the mass and concentration of the constituents in the waste stream discharged during the calendar month.

---

---

---

(iii) An estimation of the mass of constituents in the waste stream expected to be discharged during the next 12 months.

---

---

---

c. Have you had to submit a hazardous waste notification (to the POTW that you discharge to) based on the requirements of 40 CFR Part 403.12(p)?

- No  
 Yes (if "Yes" provide the POTW name, address and date of notification).

---



---

---

---

## SECTION G - TREATMENT

1. Is any form of wastewater treatment practiced at this facility?

- Yes
- No

2. Is any form of wastewater treatment (or changes to existing wastewater treatment) planned for this facility within the next three years?

Yes, describe:

---

No

3. Treatment devices or processes used or proposed for treating wastewater or sludge (check all that apply).

- Air floatation
- Centrifuge
- Chemical precipitation
- Chlorination
- Cyclone
- Filtration
- Flow equalization
- Grease or oil separation, type: \_\_\_\_\_
- Grease trap
- Grinding filter
- Grit removal
- Neutralization, pH correction
- Ozonation
- Reverse osmosis
- Screen
- Sedimentation
- Septic tank
- Solvent separation
- Spill protection
- Sump
- Biological treatment, type: \_\_\_\_\_
- Rainwater diversion or storage

- Other chemical treatment, type: \_\_\_\_\_
- Other physical treatment, type: \_\_\_\_\_
- Other type: \_\_\_\_\_

4. Description

Describe the pollutant loadings, flow rates design capacity, physical size, and operating procedures of each treatment facility checked above (attach additional sheets if necessary).

---



---



---



---

5. Attach a process flow diagram for each existing treatment system. Include process equipment, by-products, by-product disposal method, waste and by-product volumes, and design and operating conditions.

6. Describe any changes in treatment or disposal methods planned or under construction for the wastewater discharge to the sanitary sewer. Please include estimated completion dates.

---



---



---



---

7. Do you have a treatment plant operator?  No  Yes  
(if Yes):

Name: \_\_\_\_\_

Title: \_\_\_\_\_

Phone: \_\_\_\_\_

Full time: \_\_\_\_\_ (specify hours)

Part time: \_\_\_\_\_ (specify hours)

8. Is the treatment plant operator certified?  No  Yes  
(if Yes):

Certification type: \_\_\_\_\_

Certification date and number: \_\_\_\_\_

**SECTION H - FACILITY OPERATION CHARACTERISTICS**

1. Indicate whether the facility discharge is:

- Continuous through the year, or
- Seasonal - Circle the months of the year during which the business activity occurs:

J   F   M   A   M   J   J   A   S   O   N   D

Comments:

---

---

2. Does operation shut down for vacation, maintenance, or other reasons?

- No
- Yes, indicate reasons and period when shutdown occurs:

---

---

3. List types and quantity of raw materials, catalysts, intermediates and other chemicals used or planned for use (attach list if needed).

Chemical	Quantity
----------	----------

---

---

---

---

---

---

---

---

4. Building Layout - Draw to scale the location of each building on the premises. Show map orientation and location of all water meters, storm drains, numbered unit processes (from schematic flow diagram in Section E-3), public sewers, and each facility sewer line connected to the public sewers. Number each sewer.

A blueprint or drawing of the facilities showing the above items may be attached in lieu of submitting a drawing.

**SECTION I - SPILL PREVENTION**

1. Do you have chemical storage containers, bins, or ponds at your facility?  No  Yes

If “Yes”, please give a description of their location, contents, size, type, and frequency and method of cleaning. Also indicate in a diagram or comment on the proximity of these containers to a sewer or storm drain. Indicate if buried metal containers have cathodic protection.

---

---

---

---

2. Do you have floor drains in your manufacturing or chemical storage area(s)?  No  Yes  
If “Yes”, where do they discharge to?

---

---

3. If you have chemical storage containers, bins, or ponds in manufacturing area, could an accidental spill lead to a discharge to: (check all that apply)

- an on-site disposal system
- public sanitary sewer system (e.g., through a floor drain)
- storm drain
- to ground
- other, specify: \_\_\_\_\_
- not applicable, no possible discharge to any of the above routes

4. Do you have an accidental spill prevention plan (ASPP) to prevent spills of chemicals or slug discharges from entering the Authority’s collection system?

- No
- Yes (Please enclose a copy with the application)
- N/A, not applicable since there are no floor drains and/or the facility discharge(s) only domestic wastes.

**SECTION J - NON-DISCHARGED WASTES**

1. Are any waste liquids or sludges generated and not disposed of in the sanitary sewer system?

No, skip the remainder of Section J.

Yes, please describe below (attach additional sheets if necessary)

Waste Generated	Quantity (per year)	Disposal Method	Treatment Facility On-site/Off-site
_____	_____	_____	_____
_____	_____	_____	_____
_____	_____	_____	_____
_____	_____	_____	_____

2. If any of your wastes identified in No. 1 are sent to an off-site centralized waste treatment facility, identify \_\_\_\_\_ the facility's name and location:

\_\_\_\_\_

\_\_\_\_\_

3. If an outside firm removes any of the waste, described in No. 1 above, state the name(s) and address(es) of all waste haulers:

a. \_\_\_\_\_

\_\_\_\_\_

\_\_\_\_\_

Permit No. (if applicable): \_\_\_\_\_

b. \_\_\_\_\_

\_\_\_\_\_

\_\_\_\_\_

Permit No. (if applicable): \_\_\_\_\_

4. If any wastes are stored on site for greater than 90 days provide the following:

Method:  drum  roll-off container  tank  lagoon

other (specify) \_\_\_\_\_

Typical length of time waste is stored:  days  weeks  months

Typical volume of waste stored:  tons  gallons

Is storage site diked?  Yes  No

Is there surface drainage collection:  Yes  No

5. Have you been issued any Federal, State, or local environmental permits?

- No
- Yes

If Yes, please list the permit(s):

---

---

---

---

6. In the event of discharge to storm sewer or surface water, has an NPDES Permit been applied for?

- No
- Yes

If Yes, please indicate the permit number or application date:

---

**SECTION K - AUTHORIZED SIGNATURES**

Compliance certification:

1. Are all applicable Federal, State, or local pretreatment standards and requirements being met on a consistent basis?

- No
- Yes
- Not yet discharging

2. If No:

a. What additional operations and maintenance procedures are being considered to bring the facility into compliance? Also, list additional treatment technology or practice being considered in order to bring the facility into compliance.

b. Provide a schedule for bringing the facility into compliance. Specify major events planned along with reasonable completion dates. Note that if the Cherokee County Water and Sewerage Authority issues a permit to the applicant, it may establish a schedule for compliance different from the one submitted by the facility.

Milestone Activity

Completion Date

---

---

---

---

---

**Authorized Representative Statement**

I certify under penalty of law that this document and all attachments were prepared under my direction or

supervision in accordance with a system designed to assure that qualified personnel properly gather and evaluate

the information submitted. Based on my inquiry to the person or persons who manage the system, or those

persons directly responsible for gathering the information, the information submitted is, to the best of my

knowledge and belief, true, accurate, and complete. I am aware that there are significant penalties for submitting

false information, including the possibility of fine and imprisonment for knowing violations.

---

Name(s)

Title

---

Signature

Date

Telephone

Call (770) 516-3688 or e-mail [nateg@ccwsa.com](mailto:nateg@ccwsa.com) for any questions concerning this form.

**803. GREASE CONTROL PROGRAM**

**CHEROKEE COUNTY WATER AND  
SEWERAGE AUTHORITY**

**GREASE CONTROL PROGRAM**

**Revision: 1.0 May 5, 2009**

**CHEROKEE COUNTY WATER AND SEWERAGE  
AUTHORITY GREASE MANAGEMENT  
PROGRAM**

**1. PURPOSE**

The purpose of this program is to minimize the introduction of grease, fats, and oils, into the Cherokee County Water and Sewerage Authority's wastewater collection system. The main components of the program are proper sizing, installation, and maintenance of grease interceptors. The administrative and inspection requirements of establishments that discharge grease, fats, and oils into the sewer system are established herein.



## 2. DEFINITIONS

Unless otherwise stated or the context clearly indicates a different intention, the following terms shall, for the purpose of this document, be defined as follows:

1. **Active interior recovery device (AIRD)**- An active automatic separator and remover of grease, fats, and oils from effluent discharge that cleans itself of accumulated grease, fats, and oils at least once every 24 hours, utilizing an electromechanical apparatus to accomplish removal.
2. **CCWSA**- The Cherokee County Water and Sewerage Authority.
3. **Clean-out port**- A pipe that extends from the ground surface to the interior of the passive exterior device ("PED") so as to allow access and inspection of the interior of the PED.
4. **Effluent T-valve**- A T-shaped valve extending from the ground surface below grade into the PED to a depth allowing recovery of water located under the layer of grease, fats, and oils to be discharged.
5. **Exterior grease trap**- A grease trap that contains baffles sufficient to allow a proper separation of grease from water and is located outside of the building.
6. **Grease, fats and oils recovery system or grease recovery system**- A system of interceptors, separators, traps, or grease recovery devices, which prevents free floating grease, fats, and oils from entering the sewage system by recovering and removing these substances from water.
7. **Grease-laden waste**- Effluent discharge that is produced from food processing, food preparation, or other commercial source where grease, fats, and oils enter the CCWSA wastewater collection system through automatic dishwasher pre-rinse stations, sinks, or other appurtenances.
8. **(Grease) trap**- An interceptor, separator, or recovery vehicle that prevents free-floating grease, fats, and oil from entering the sewage disposal system. Also includes a passive interceptor with a rated flow exceeding 50 gallons per minute or minimum storage capacity of 750 gallons or more and which is located outside the building.
9. **Grease recovery device**- Any separator of grease, fats, or oils, excluding passive interior devices.
10. **Interior grease trap**- A grease trap located inside a food service establishment; may be an active or passive trap.
11. **Manifest**- A log or recording of the volume, date of removal, and disposal destination of pumped materials from a grease trap or other device.
12. **Passive exterior device (PED)** - An oil/water-separating container that requires pumping and is housed outside a building or structure.

13. **Passive interior device (PID)**- An oil/water separating container that requires normal manual cleaning, by pumping or bailing, and is housed inside a building or structure. A passive interceptor with no moving parts with a rated flow of 50 gallons per minute or less that serves as a fixture trap and is located inside a building.
14. **Solids transfer/grease recovery device**- An active automatic pretreatment device which macerates coarse solids and separates/recovers free floating grease, fats, and oils from effluent. The device cleans itself of accumulated grease, fats, and oils at least once every 24 hours, utilizing electromechanical apparatus to accomplish recovery and removal.
15. **User** - Any establishment that discharges grease, fats, or oil into the CCWSA Sewer System. The establishment's owners, operators, or their agents that receive county wastewater system service and/or reclamation facility service. The term excludes industrial facilities because they are permitted under the CCWSA Industrial Pretreatment Program.

### 3. GENERAL

Users that generate grease, fats, or oil, or any combination thereof, and discharge water to a CCWSA Wastewater Treatment Facility shall be required to install, operate, clean, and maintain a grease recovery system of appropriate size and design to achieve compliance with requirements set forth under this section.

### 4. ADMINISTRATION

1. **Registration requirement**- As a condition of use, each user required to install a grease, fats, and oils recovery system as set forth in Section 5 shall register its recovery system with the CCWSA. Such registration form shall include the name, address, telephone number, and factors indicating the potential for grease-laden waste to be introduced into the wastewater collection system. CCWSA will review the registration form and provide the user with a Discharge Permit. The Discharge Permit will include a permit number, pumping frequency requirements, an expiration date, and the design requirements of a compliant grease removal system. The user shall keep the Discharge Permit in a conspicuous location where it can be inspected by the Health Department and CCWSA personnel upon request. No fee will be charged by CCWSA for the initial discharge permit.
2. **Annual Permit Review**-CCWSA shall keep a continuous log of all permitted users, including their permit number, address, and the contact information of the user. CCWSA will review Discharge Permits annually. Those found to be in compliance with existing federal, state, and local laws and regulations will be renewed by CCWSA. Any user found to be in noncompliance shall be subject to penalties under Section 9 herein. Upon the non-compliant user's demonstration of appropriate corrective actions to achieve compliance with all provisions of CCWSA Grease Control Program, CCWSA may renew said user's permit.
3. **Records**- All users must keep a record of any cleaning or maintenance of their grease recovery system. These records must include a manifest as listed in Sections 4.4 and 4.5 below. The manifest must be kept on-site for a period of three (3) years.

4. **Manifest-** All removal of grease traps contents must be tracked by a manifest that confirms pumping, hauling, and disposal of wastes whether it is collected by interior or exterior grease traps.
5. **Information-** This manifest shall contain the following information:
  - a. Generator information, including name, address, volume pumped, date and time of the pumping, and the signature of the generator verifying the information.
  - b. Transporter information, including company name, address, license plate number, permit number, the driver's name, and the driver's signature verifying transporter information.
  - c. Receiving information, including the facility's name, address, date and time of receiving, EPD number, and signature verifying receipt of the waste.
6. **Reporting-** Completed exterior grease trap cleaning manifests must be mailed to the CCWSA's Industrial Pretreatment Coordinator within 14 days after the trap is cleaned.
7. **Maintenance log-** For all interior grease traps, whether active or passive, each user of a grease recovery system shall maintain a continuous log indicating each cleaning and any maintenance for the previous 12 months. This log shall be kept in a conspicuous location where it can be inspected by the Health Department and CCWSA personnel upon request.

## 5. GREASE RECOVERY SYSTEMS

1. **Where required-** Grease, fats, and oils recovery systems shall be installed where grease-laden waste from food preparation, food processing or other commercial use will be discharged into the CCWSA wastewater collection system.
2. **Technology required-** An approved grease, fats, and oils recovery system shall be installed consisting of one or a combination of the following methods:
  - a. Passive technology that is an approved exterior grease trap.
  - b. Active technology including:
    1. An approved grease recovery device; or
    2. An approved solids transfer/grease transfer device.
3. **Prohibited discharge-** Waste that does not contain grease, fats, or oils and that otherwise does not require grease separation treatment shall not be discharged into the grease recovery system. Wastewater from dishwasher machines or wastewater that otherwise exceeds 130 degrees Fahrenheit shall not be introduced into any interior grease recovery device. Food-waste grinders shall not discharge into the building drainage system through a grease trap or grease recovery device.
4. **Dumpster pads-** Dumpster pads may be allowed to connect to the wastewater collection system under the following conditions:
  - a. The dumpster pad is constructed in such a manner so as to protect the drainage connection from storm water runoff in a method that is approved by the CCWSA Construction Inspector. The dumpster pad design must be in compliance with the *Cherokee County Water and Sewerage Authority Water and Sewer Specifications Standard No. S728 (Dumpster Pad Detail)* and meet the requirements of Section 320.

Additional information on the *Cherokee County Water and Sewerage Authority Water and Sewer Specifications* can be found at [www.ccwsa.com](http://www.ccwsa.com).

- b. The drain is connected to an exterior grease trap of at least 1500 gallons which will be maintained by the user in the method prescribed by this section for other exterior grease traps.

5. ***Passive exterior device (PED) requirements-***

- a. Each PED design, including size, type, and location shall be reviewed and approved by the CCWSA's Construction Inspector in substantial conformity to a grease trap detail approved and amended from time to time by CCWSA. PEDs shall:
  1. Be sized and engineered based upon the anticipated load and/or conditions of actual use.
  2. Be constructed of sound durable material, not subject to excessive corrosion or decay, and shall be water and gas tight if the PED is made of pre-cast or poured-in-place concrete.
  3. Be traffic-worthy with at least two manhole openings and one clean-out port or manhole over the discharge T-valve.
  4. Contain baffles sufficient to allow a proper separation of grease from water.
  5. Be a minimum of 1500 gallons in size. Multiple PEDs are allowed.
  6. Contain a test manhole on the discharge sewer line to allow observation, sampling, and measurement of grease discharges. Restrooms are to be routed downstream of the test manhole so that they do not flow through the PED. This manhole will serve only the PED and no other sewer lines shall enter this manhole.
- b. ***Passive interior devices (PIDs)*** - There shall be no PIDs installed in any user's premises upon the effective date of this article.
- c. ***Sizing:*** All grease traps shall have a capacity and design in compliance with the *Cherokee County Water and Sewerage Authority Water and Sewer Specifications* Standard No. S727 (Typical Grease Trap Design Specifications) and meet the requirements of Section 318. The design must be approved by the CCWSA Construction Inspector. Additional information on the *Cherokee County Water and Sewerage Authority Water and Sewer Specifications* can be found at [www.ccwsa.com](http://www.ccwsa.com).

6. ***Active interior recovery device requirements-*** AIRDs may be allowed in lieu of PEDs in accordance with the following conditions:

- a. The method of food preparation involves and/or creates little or no discharge of grease; or
- b. A technically logistical reason exists as to why an exterior grease trap cannot be installed (i.e., conflicts with existing utilities, elevation disparities, or location on a second floor).
- c. The installation or use of all grease recovery devices must be approved by the CCWSA's Construction Inspector.
  1. ***Location-*** Grease recovery devices shall receive all grease-laden waste discharge from the major point sources. A floor drain shall not be considered a major point source.

2. **Sizing-** Grease recovery devices shall be sized based upon the anticipated load and/or conditions of actual use and the manufacturer's recommendation. The CCWSA's Construction Inspector must approve the size of the grease recovery device.

## **6. ALTERNATIVE METHODS**

1. **Alternative technology/methods-** Engineered alternative technology or methods may be permitted, provided the technology or method meets the requirements of the *Cherokee County Water and Sewerage Authority Water and Sewer Specifications* Section 318. The installation or use of any alternative technology or methods must be approved by the CCWSA Construction Inspector. Additional information on the *Cherokee County Water and Sewerage Authority Water and Sewer Specifications* can be found at [www.ccwsa.com](http://www.ccwsa.com).
2. **Biological or chemical treatment agents-** The use of biological or chemical treatment agents will not be permitted on any user's premises upon the effective date of this article.

## **7. USER RESPONSIBILITY**

1. **User responsibility and acknowledgement-**
  - a. Users that are required to install grease, fats, and oils recovery system shall be responsible for the cleaning and maintenance of the grease, fats, and oils recovery systems located on the property. The user shall be responsible for maintaining any grease recovery system pursuant to Subsection b. below and in such a manner that the grease, fats, or oil discharge shall not exceed the CCWSA's maximum discharge limits as developed and approved by the CCWSA Board of Directors. Further information on the CCWSA's discharge limits and prohibited discharge standards can be acquired by contacting the CCWSA Industrial Pretreatment Coordinator.
  - b. The user shall maintain accurate records (manifests and logs) of the dates of cleaning and the means of disposal of grease, fats, and oils. These records are subject to inspection and review by CCWSA pursuant to and in accordance with Section 4.3 above.
  - c. Any removal and hauling of grease, fats, and oils shall be performed by a licensed waste disposal or rendering firm. If the grease recovery system fails to prevent discharge over CCWSA's maximum discharge limits, CCWSA will require the user to repair, replace, or upgrade their grease removal system, which may include one or more of the user's devices, at the user's expense.
  - d. All costs related to the building's sewer installation, grease recovery system, connection, and registration shall be borne by the user.
2. **Grease trap maintenance-**

- a. All grease traps shall be maintained by the user at the user's expense. Maintenance shall include the complete recovery of all contents, including floating materials, wastewater, bottom sludges, and solids. All grease recovery systems, including passive interior devices, passive exterior devices, and any grease recovery devices, shall be properly and adequately maintained by the user so as to achieve the intended purpose of the device.
- b. In the maintaining of these grease recovery systems, the user shall be responsible for proper recovery, removal, and disposal by appropriate, approved means of the captured material by a licensed waste disposal or rendering firm.
- c. ***Pumping/cleaning frequency-*** All grease recovery systems shall be completely pumped out at a minimum of once every three months, or at a frequency determined by the CCWSA to comply with this section or the manufacturer's recommendation. The frequency of removal shall be such as to ensure no overflow of oils or grease into the CCWSA wastewater collection system. Decanting or discharging of removed waste back into the trap from which the waste was removed or to any other grease trap or sanitary sewer connection for the purpose of reducing the volume to be hauled is prohibited.

## 8. ENFORCEMENT

1. ***Monitoring-*** The user shall install a test manhole on the discharge sewer to allow observation, sampling, and measurement of grease recovery system discharges. This manhole shall be installed so as to be safe and accessible at all times.
2. ***Inspection and entry-*** Any authorized representative of CCWSA bearing proper credentials and identification shall be permitted to enter and inspect all properties without prior notification. This right of inspection shall include the right to measure, observe, monitor, sample, test, record, review and make copies of all pertinent documents in accordance with this section.

## 9. VIOLATIONS AND PENALTIES

1. ***Violations-*** It shall be unlawful for any user to discharge water to CCWSA in a manner in violation of this section or of any conditions set forth in this article. Any person who violates any provision of this section shall, in addition to the penalties specified herein, be subject to the provisions contained in the *Cherokee County Water and Sewerage Authority Industrial Pretreatment Program Manual* to the extent such violations, notices, penalties, and fines are not addressed in this section.
2. ***Notice of noncompliance-*** If through inspection, it is determined that the user has failed to comply with the provisions of this section, a written warning of the violation shall be given to the user, the contractor named in the permit, or the user's authorized agent. The notice shall set forth the violation and the measure needed to achieve compliance. The user shall

have seven (7) days from receipt of this notice to comply. Where an emergency exists, a written warning shall be given to the user, and user will have 24 hours to comply.

3. **Failure to comply-** CCWSA shall have the power and authority to enter upon the property of any user who, after having received a written warning, has failed to comply with the provisions of this article, to terminate the user's water and/or wastewater service in any manner deemed necessary and appropriate by CCWSA.
4. **Overflow penalty-** Any sewer or manhole overflow traced to an inadequately operating grease recovery system or lack of a grease recovery system will result in a service charge to the user. The service charge shall include the cost of cleaning up the overflow and for cleaning grease out of the immediately adjacent contaminated CCWSA wastewater collection system. This penalty will be doubled with each successive overflow. Additionally, the user shall be responsible for payment of any fine levied by the Georgia Environmental Protection Division against the county as a result of overflows in the county wastewater collection system caused by grease traced to any inadequate or absent grease recovery system.
5. **Alternative penalties-** Any violation of this section may also be enforced by civil penalties or criminal prosecution pursuant to Section 6.11 of the *Cherokee County Water and Sewerage Authority Industrial Pretreatment Program Manual*.

## **804. GREASE CONTROL FAQ**

### *Cherokee County Water and Sewerage Authority Grease Control Program Frequently Asked Questions*

#### **What is the purpose of the Grease Control Program?**

The program was established to reduce the amount of grease, fats and oils in the wastewater collection system. This goal is to minimize the damage grease causes to sewer lines, pump stations and wastewater treatment plants as well as prevent sewage overflows or spills often caused by grease blockages in the sewer lines.

#### **Is the Grease Control Program making a difference?**

Sewer spills caused by grease blockages are down 75%. This program is making a positive impact on the environment and the waters of Cherokee County.

#### **Who do I contact with questions regarding the Grease Control Program?**

Please contact:

Nate Giddens  
Industrial Pretreatment Coordinator  
Cherokee County Water and Sewerage Authority  
260 Colemans Bluff Drive  
Woodstock, GA 30188  
Phone: (770) 516-3688 ext. 7  
Fax: (770) 592-8844  
E-mail: [nateg@ccwsa.com](mailto:nateg@ccwsa.com)

#### **What are the most important things for me, the business owner or operator, to know about the Grease Control Program?**

1. You are required to get your grease recovery system pumped completely at the frequency required on your permit.
2. If you have a PED or exterior grease recovery system, you are required to mail a copy of your manifest to CCWSA within 14 days of the cleaning.
3. If you have a PID, AIRD, or interior grease recovery device, you are required to maintain a continuous log indicating each cleaning and any maintenance for the previous 12 months.
4. You are required to keep copies of cleaning manifests on-site for a period of 3 years.

#### **Can I fax copies of my manifest to CCWSA?**

CCWSA will accept manifests via fax. However, it will not be held accountable for missing faxes. Section 4.6 of The Grease Control Program requires users to mail their completed manifests to CCWSA.

#### **Where do I mail copies of my cleaning manifests?**

Please mail your completed manifests to the address listed above.

#### **Will CCWSA notify me when it is time to have my grease recovery device pumped?**

Throughout the first year of the Grease Control Program, CCWSA has called or e-mailed its customers reminding them of program and permit requirements. From this point forward, CCWSA will no longer remind customers of their requirements and violations will be strictly enforced.



**What are the enforcement actions if I do not meet the requirements of my permit or the Grease Control Program?**

1st Offense- Written Notice of Violation (NOV). You will be given 7 days to achieve compliance.

2<sup>nd</sup> Offense- Written NOV that includes a \$250 Administrative Fine. At CCWSA's discretion, you will be given 1 to 7 days to achieve compliance. You will be required to pay the fine within 15 days of receipt of the NOV.

3rd Offense- Written NOV that will include immediate termination of water and sewer service. Service will not be restored until compliance is achieved and fines and reconnection fees are paid in full. .

NOTE: CCWSA has the right to enforce alternative penalties that may include publishing violations in the largest county newspaper, notification of the Cherokee County Environmental Health Department, fines of up to \$1,000 per day – per violation, Civil Penalties, and Criminal Prosecution.

**What if my commercial waste hauler forgets to pump my grease recovery device or doesn't send a copy of my cleaning manifest to CCWSA?**

Do not count on your hauler to maintain a set pumping schedule or send copies of your manifests to CCWSA. It is your permit and your responsibility to make sure that your device is pumped on time and CCWSA receives a copy of your manifest within 14 days of the cleaning.

**Does CCWSA perform compliance inspections?**

CCWSA performs unscheduled compliance inspections conducted by a CCWSA Inspector. The inspection may include taking a measurement of the combined grease and solids in the grease recovery device and a review of cleaning records.

**805. Grease Control Program User Registration Form**

**Cherokee County Water and Sewerage Authority  
Grease Control Program User Registration Form**

If your establishment discharges grease, fats, or oil into the sewer system, your facility is required by the Cherokee County Water and Sewerage Authority to operate and maintain a grease recovery system that prevents the excessive discharge of grease, fats, and oils to the wastewater collection system. Please fill out this form accurately and legibly and return to:

ATTN: Nate Giddens  
CCWSA Industrial Pretreatment Coordinator  
260 Colemans Bluff Dr.  
Woodstock, GA 30188

**CCWSA Sewer Account Number:** \_\_\_\_\_

**Facility Name:** \_\_\_\_\_

**Facility Address:** \_\_\_\_\_

\_\_\_\_\_  
\_\_\_\_\_

**Mailing Address:** \_\_\_\_\_  
(If Different)

\_\_\_\_\_  
\_\_\_\_\_

**Owner or Corporate Contact:** \_\_\_\_\_

Telephone: \_\_\_\_\_

E-Mail: \_\_\_\_\_

Fax Number: \_\_\_\_\_

**On-Site Contact:** \_\_\_\_\_

Telephone: \_\_\_\_\_

E-Mail: \_\_\_\_\_

Fax Number: \_\_\_\_\_

**Indicate the Classification of your Facility:**

Restaurant: \_\_\_\_\_

Grocery Store: \_\_\_\_\_

Fast Food: \_\_\_\_\_

Car Wash: \_\_\_\_\_

Cafeteria: \_\_\_\_\_

Pet Grooming: \_\_\_\_\_

Day Care Center/Pre-School: \_\_\_\_\_

School Cafeteria: \_\_\_\_\_

Hair Salon/Barber Shop: \_\_\_\_\_

Auto Shop: \_\_\_\_\_

Other (Describe): \_\_\_\_\_

**In Business Since (Date):** \_\_\_\_\_

**Hours of Operation (Include preparation and clean up time):**

Monday: \_\_\_\_\_

Tuesday: \_\_\_\_\_

Wednesday: \_\_\_\_\_

Thursday: \_\_\_\_\_

Friday: \_\_\_\_\_

Saturday: \_\_\_\_\_

Sunday: \_\_\_\_\_

**Number of Seats:** \_\_\_\_\_

**Number of Employees:** \_\_\_\_\_

**Number of Meals Served Per Day:** \_\_\_\_\_

**Indicate the Number of the Following Fixtures in your Facility:**

Kitchen Hand Sinks: \_\_\_\_\_ Double Compartment Sinks: \_\_\_\_\_

Pre-rinse Sinks: \_\_\_\_\_ Dishwashers: \_\_\_\_\_

Single Compartment Sinks: \_\_\_\_\_

**Passive Exterior Device(s) (PED) or Exterior Grease Trap(s):** YES: \_\_\_\_ NO: \_\_\_\_

Size of Device(s) or Trap(s) (Volume in Gallons): \_\_\_\_\_

Manufacturer: \_\_\_\_\_

Installation Date: \_\_\_\_\_

Is the pumping of PED(s) Contracted? YES: \_\_\_\_\_ NO: \_\_\_\_\_

Who Does the Pumping/Hauling? \_\_\_\_\_

\_\_\_\_\_

\_\_\_\_\_

What is the Pumping Frequency?

Weekly: \_\_\_\_\_

Quarterly: \_\_\_\_\_

800-67

Bi-Monthly: \_\_\_\_\_

Bi-Annually: \_\_\_\_\_

Monthly: \_\_\_\_\_

Annually: \_\_\_\_\_

As Needed: \_\_\_\_\_

Are Waste Manifests Used? YES: \_\_\_\_\_ NO: \_\_\_\_\_

(If you checked yes, attach a copy of the latest manifest.)

Is the PED Pumped Completely? YES: \_\_\_\_\_ NO: \_\_\_\_\_ UNKNOWN: \_\_\_\_\_

Where is the Grease Disposed? \_\_\_\_\_

Does Sanitary Waste Flow to the PED(s)? YES: \_\_\_\_\_ NO: \_\_\_\_\_ UNKNOWN: \_\_\_\_\_

Does the Dishwasher Flow to the PED(s)? YES: \_\_\_\_\_ NO: \_\_\_\_\_ UNKNOWN: \_\_\_\_\_

Does the Garbage Grinder Flow to the PED(s)? YES: \_\_\_\_\_ NO: \_\_\_\_\_ UNKNOWN: \_\_\_\_\_

**Passive Interior Device(s) (PID) (Under-sink Trap):** YES: \_\_\_\_\_ NO: \_\_\_\_\_

Size of PID(s) (Volume in Gallons): \_\_\_\_\_

Manufacturer: \_\_\_\_\_

Installation Date: \_\_\_\_\_

What is the Cleaning Frequency of the PID(s)?

Weekly: \_\_\_\_\_

Quarterly: \_\_\_\_\_

Bi-Monthly: \_\_\_\_\_

Bi-Annually: \_\_\_\_\_

Monthly: \_\_\_\_\_

Annually: \_\_\_\_\_

As Needed: \_\_\_\_\_

Do you keep a Maintenance Log or Manifest for the PID(s) Cleaning? YES: \_\_\_\_\_ NO: \_\_\_\_\_

(If you checked yes, attach a copy of the latest manifest.)

Where is the Grease from the PID(s) Disposed? \_\_\_\_\_

**Active Interior Recovery Device (AIRD)/Solids Transfer/Grease Recovery Device?**

YES? \_\_\_\_\_ NO: \_\_\_\_\_

Size of Device(s) (Volume in Gallons): \_\_\_\_\_

Manufacturer: \_\_\_\_\_

Installation Date: \_\_\_\_\_

Is the pumping of the Device(s) Contracted? YES: \_\_\_\_\_ NO: \_\_\_\_\_

Who Does the Pumping/Hauling? \_\_\_\_\_

\_\_\_\_\_

\_\_\_\_\_

What is the Pumping Frequency?

Weekly: \_\_\_\_\_

Quarterly: \_\_\_\_\_

Bi-Monthly: \_\_\_\_\_

Bi-Annually: \_\_\_\_\_

Monthly: \_\_\_\_\_

Annually: \_\_\_\_\_

As Needed: \_\_\_\_\_

Are Waste Manifests Used? YES: \_\_\_\_\_ NO: \_\_\_\_\_

(If you checked yes, attach a copy of the latest manifest.)

Is the Device(s) Pumped Completely? YES: \_\_\_\_\_ NO: \_\_\_\_\_ UNKNOWN: \_\_\_\_\_

Where is the Grease Disposed? \_\_\_\_\_

Does the Dishwasher Flow to the Device(s)? YES: \_\_\_\_\_ NO: \_\_\_\_\_ UNKNOWN: \_\_\_\_\_

Does the Garbage Grinder Flow to the Device(s)? YES: \_\_\_\_\_ NO: \_\_\_\_\_ UNKNOWN: \_\_\_\_\_

**Do you use Biological/Chemical Treatment Agents? YES: \_\_ NO: \_\_ UNKNOWN: \_\_**

Manufacturer: \_\_\_\_\_

Product Name: \_\_\_\_\_

**Does the Kitchen Recycle all Available Oil Products?** YES: \_\_NO: \_\_UNKNOWN: \_\_

What is the Name of the Recycling Firm? \_\_\_\_\_

"I certify under penalty of law that this document and all attachments were prepared under my direction or supervision in accordance with a system designed to assure that qualified personnel properly gather and evaluate the information submitted. Based on my inquiry of the person or persons who manage the system or those persons directly responsible for gathering the information, the information submitted is to the best of my knowledge and belief, true, accurate and complete. I am aware that there are significant penalties for submitting false information, including the possibility of fines for knowing violations"

\_\_\_\_\_  
Signature of Authorized Representative

\_\_\_\_\_  
Date

Call (770) 516-3688 or e-mail [nateg@ccwsa.com](mailto:nateg@ccwsa.com) for any questions concerning this form.



2010  
SEWER  
DETAILS



**NOTES:**

1. MANHOLE RIMS ARE TO BE FLUSH WITH PAVEMENT IN PAVED AREAS.
2. MANHOLE RIMS ON OUTFALL LINES ARE TO BE 18" ABOVE GROUND.
3. MANHOLE RIMS IN FUTURE STREETS ARE TO BE 48" ABOVE GROUND.
4. SEE DETAIL S704 REGARDING SAFETY PLATFORMS.
5. SEE DETAIL S730 REGARDING LAST MANHOLE ON SEWER LINE BEFORE A WET WELL.

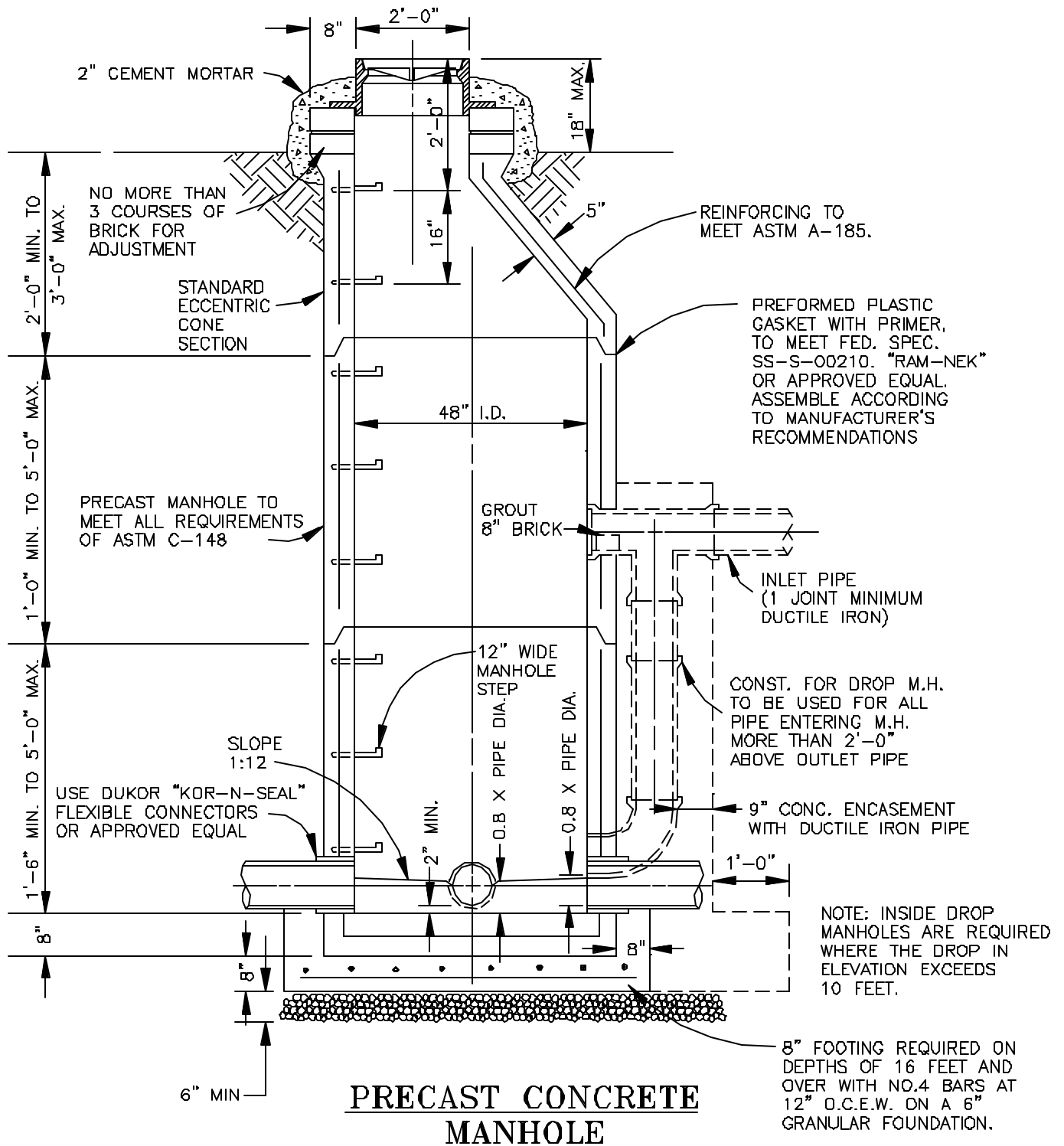

**PRECAST CONCRETE  
MANHOLE**

**CHEROKEE COUNTY  
WATER & SEWERAGE  
AUTHORITY**

**PRECAST  
CONCRETE  
MANHOLE  
CONSTRUCTION STANDARD**

DATE:	FEB. '03
APPROVED:	

STANDARD  
NO.  
**S701**

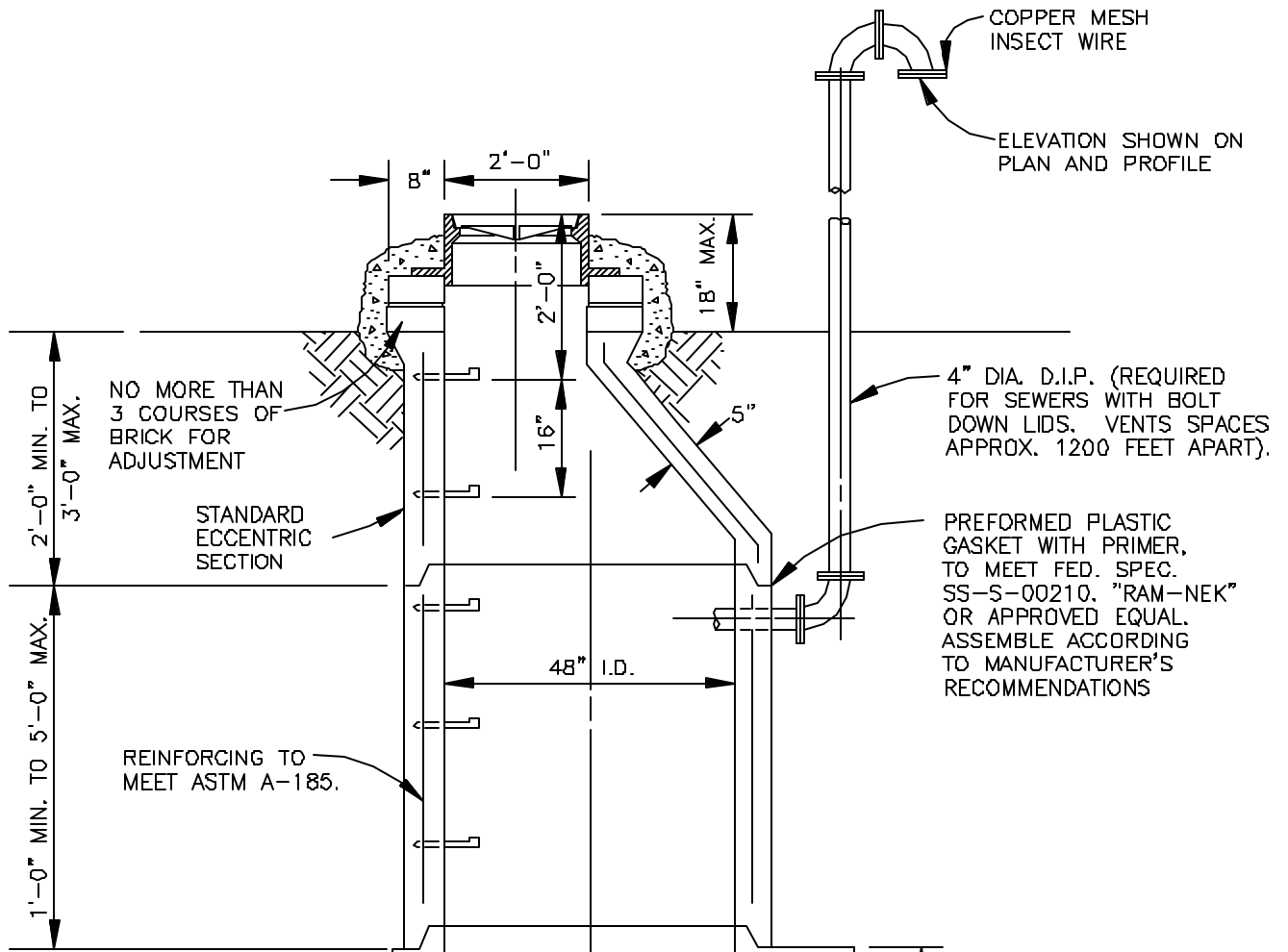

**NOTES:**

1. MANHOLE RIMS ARE TO BE FLUSH WITH PAVEMENT IN PAVED AREAS.
2. MANHOLE RIMS ON OUTFALL LINES ARE TO BE 18" ABOVE GROUND.
3. MANHOLE RIMS IN FUTURE STREETS ARE TO BE 48" ABOVE GROUND.
4. SEE DETAIL S704 REGARDING SAFETY PLATFORMS.
5. SEE DETAIL S730 REGARDING LAST MANHOLE ON SEWER LINE BEFORE A WET WELL.

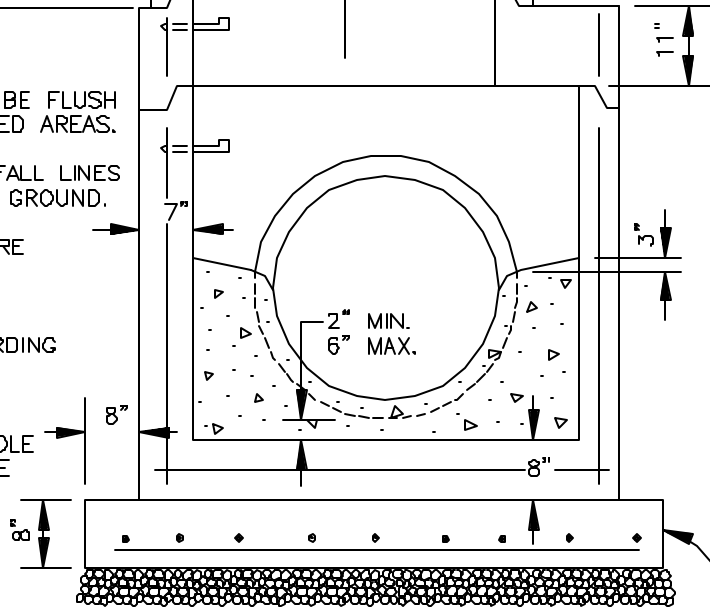

8" FOOTING REQUIRED ON DEPTHS OF 16 FEET AND OVER WITH NO.4 BARS AT 12" O.C.E.W. ON A 6" GRANULAR FOUNDATION.

**CHEROKEE COUNTY  
WATER & SEWERAGE  
AUTHORITY**

**STANDARD  
VENTED MANHOLE**  
(FOR PIPE LARGER THAN 18")  
CONSTRUCTION STANDARD

DATE: FEB. '03

APPROVED:

STANDARD  
NO.  
**S702**

**NOTES:**

1. MANHOLE RIMS ARE TO BE FLUSH WITH PAVEMENT IN PAVED AREAS.
2. MANHOLE RIMS ON OUTFALL LINES ARE TO BE 18" ABOVE GROUND.
3. MANHOLE RIMS IN FUTURE STREETS ARE TO BE 48" ABOVE GROUND.
4. SEE DETAIL S704 REGARDING SAFETY PLATFORMS.
5. SEE DETAIL S730 REGARDING LAST MANHOLE ON SEWER LINE BEFORE A WET WELL.

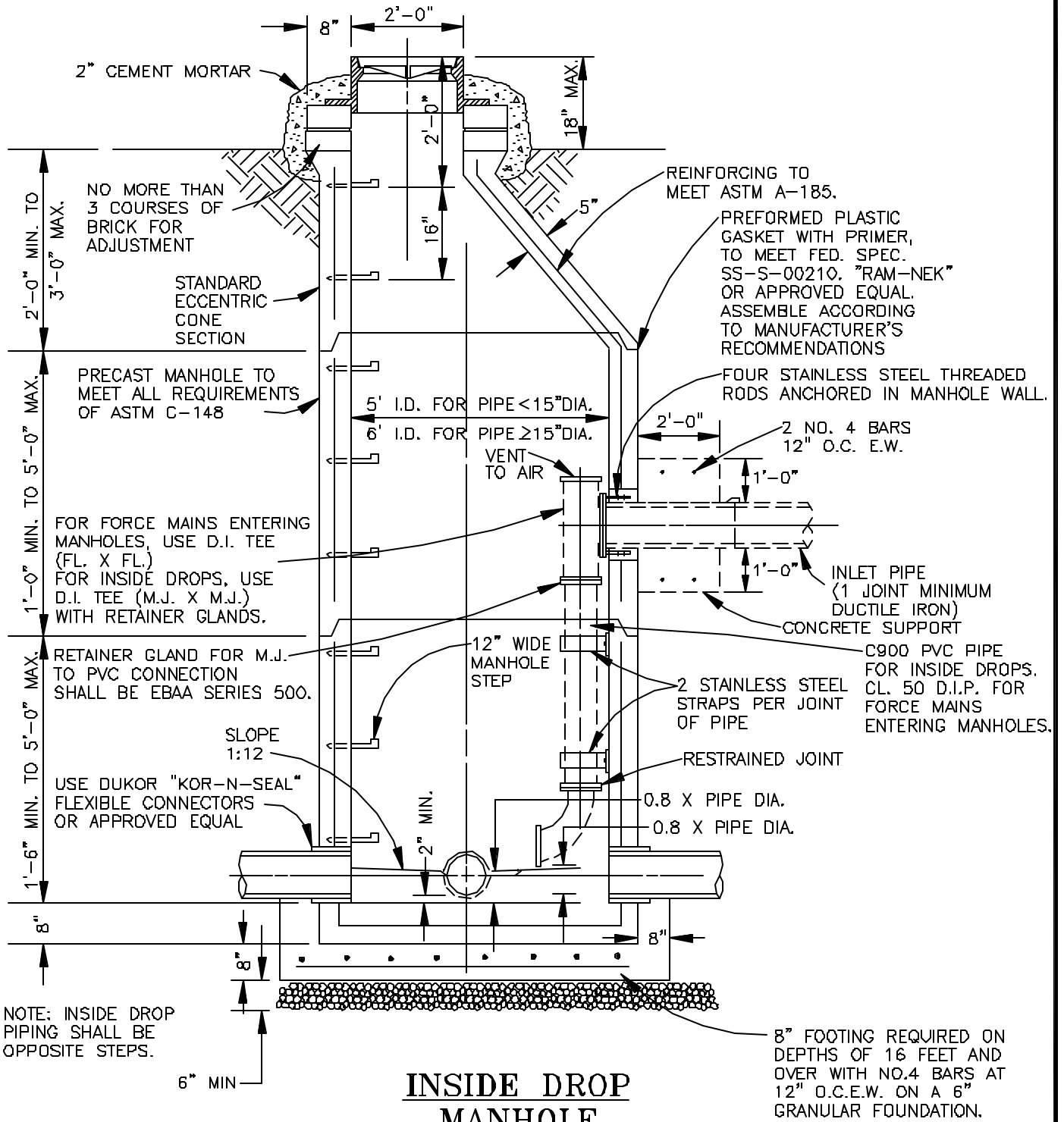

**INSIDE DROP  
MANHOLE**

(REQUIRED WHERE DROP IN ELEVATION EXCEEDS 10 FEET.)

**CHEROKEE COUNTY  
WATER & SEWERAGE  
AUTHORITY**

**INSIDE  
DROP  
MANHOLE  
CONSTRUCTION STANDARD**

DATE: FEB. '03

APPROVED:

STANDARD  
NO.  
**S703**

**NOTES:**

1. ALL MANHOLES FOR 24" DIAMETER AND LARGER SEWER PIPE SHALL BE 5'-0" IN DIAMETER. ALL MANHOLES FOR SEWER PIPES LESS THAN 24" IN DIAMETER SHALL BE 4'-0" IN DIAMETER.
2. SAFETY PLATFORMS ARE REQUIRED ON ALL MANHOLES EQUAL TO OR GREATER THAN 16 FEET IN DEPTH.
3. SAFETY PLATFORMS ARE TO BE PLACED AT A MAXIMUM DISTANCE OF 8' - 10' APART. THE FIRST PLATFORM SHALL BE 8' BELOW THE COVER. THERE SHALL BE A MINIMUM OF 8' FROM THE INVERT TO THE BOTTOM OF THE LOWEST PLATFORM.
4. PLATFORMS ARE TO BE DESIGNED TO OBTAIN A STRENGTH OF 4000 PSI IN 28 DAYS.
5. MANHOLE AND PLATFORM SHALL MEET A.S.T.M. SPECS. C-478.
6. REINFORCING STEEL SHALL HAVE A MINIMUM YIELD STRENGTH OF 60,000 PSI.
7. SAFETY PLATFORMS SHALL BE PLACED BETWEEN RISERS.
8. SAFETY PLATFORMS SHALL BE PRECAST CONCRETE OR APPROVED EQUAL.
9. ALTERNATE OPENINGS IN SAFETY PLATFORMS AS INDIVIDUAL DESCENDS.
10. PLATFORMS SHALL BE CORED FOR PIPES FOR INSIDE DROPS.

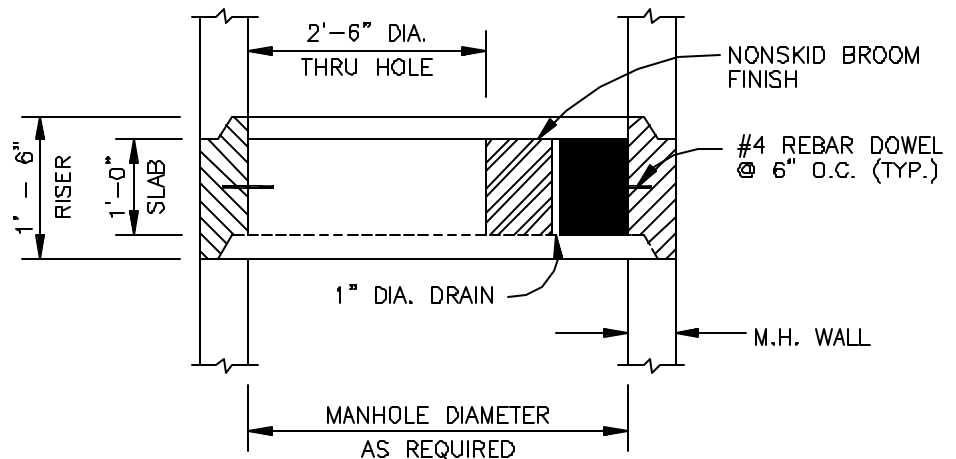
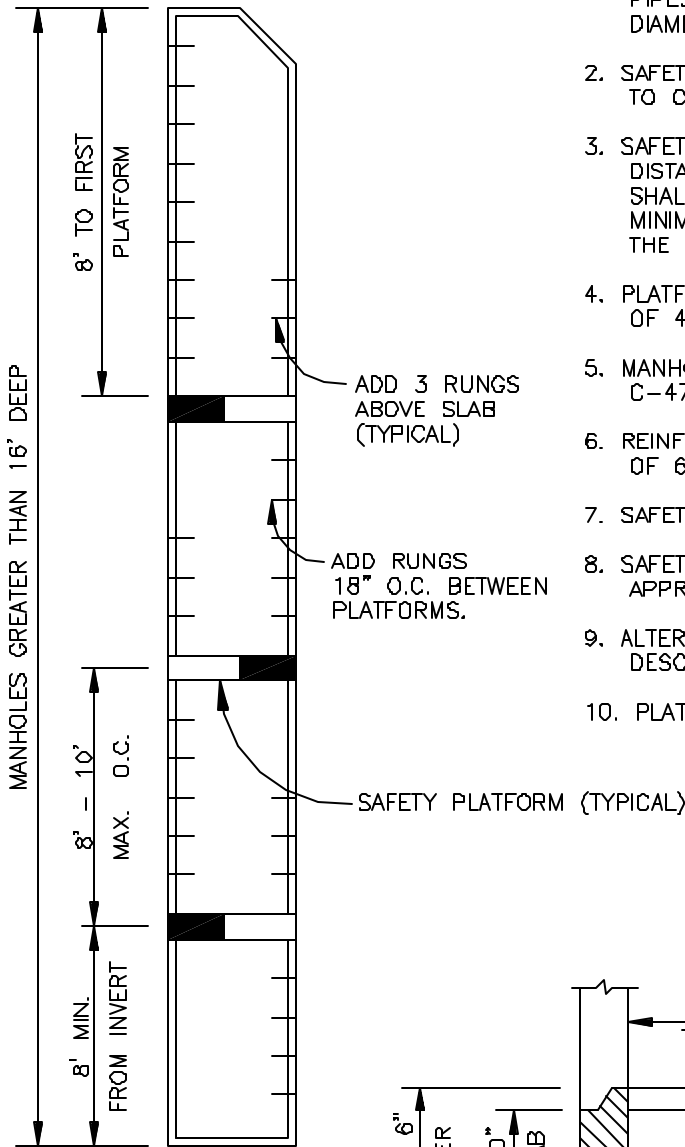

**MANHOLE PLATFORMS**

NOT TO SCALE

**CHEROKEE COUNTY  
WATER & SEWERAGE  
AUTHORITY**

**SAFETY  
PLATFORMS**

CONSTRUCTION STANDARD

DATE: FEB. '03

APPROVED:

STANDARD  
NO.

**S704**

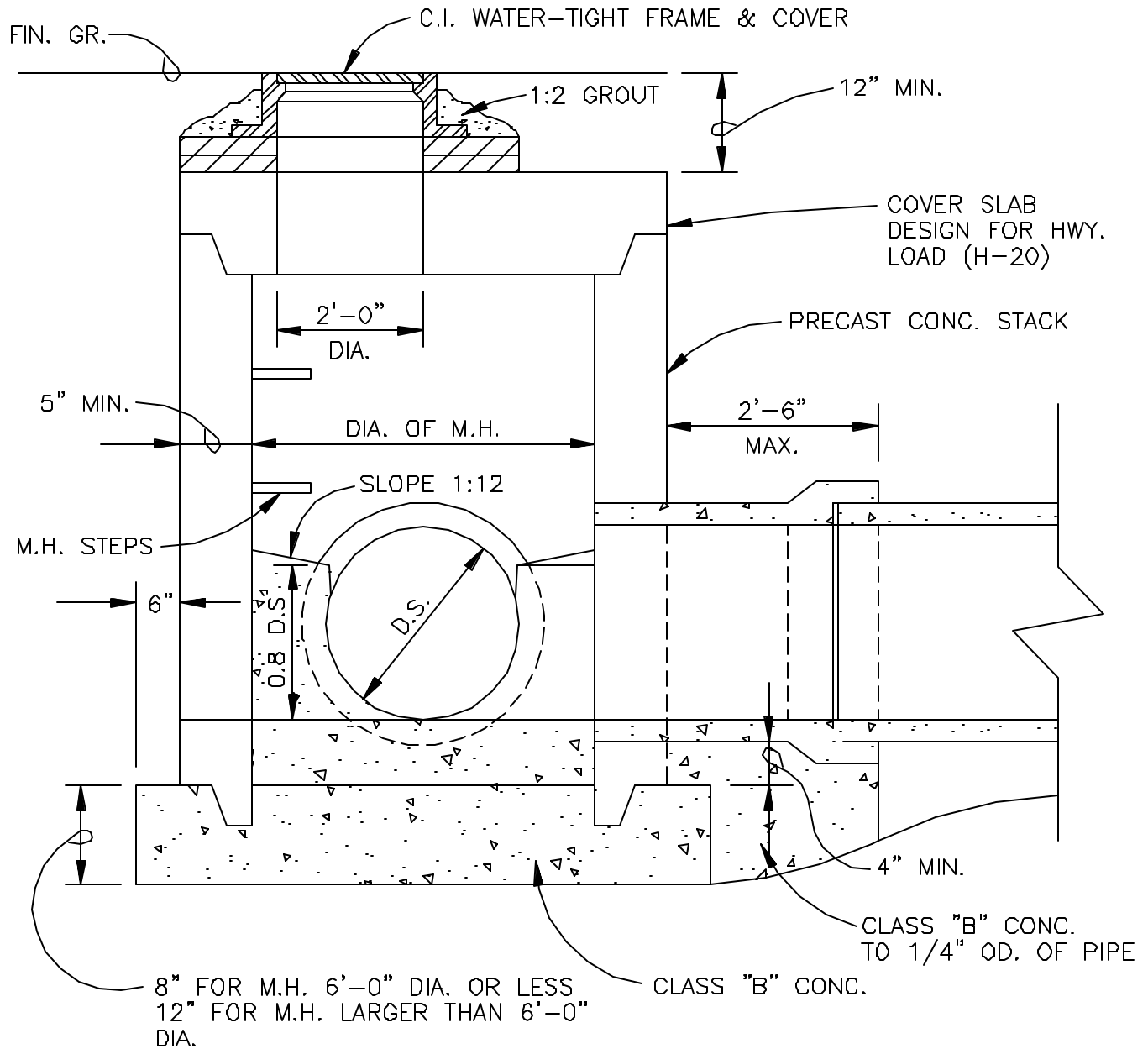

### SHALLOW MANHOLE DETAIL

<b>CHEROKEE COUNTY WATER &amp; SEWERAGE AUTHORITY</b>	<b>SHALLOW MANHOLE DETAIL</b> CONSTRUCTION STANDARD	DATE:	FEB. '03	STANDARD NO. <b>S705</b>
		APPROVED:		

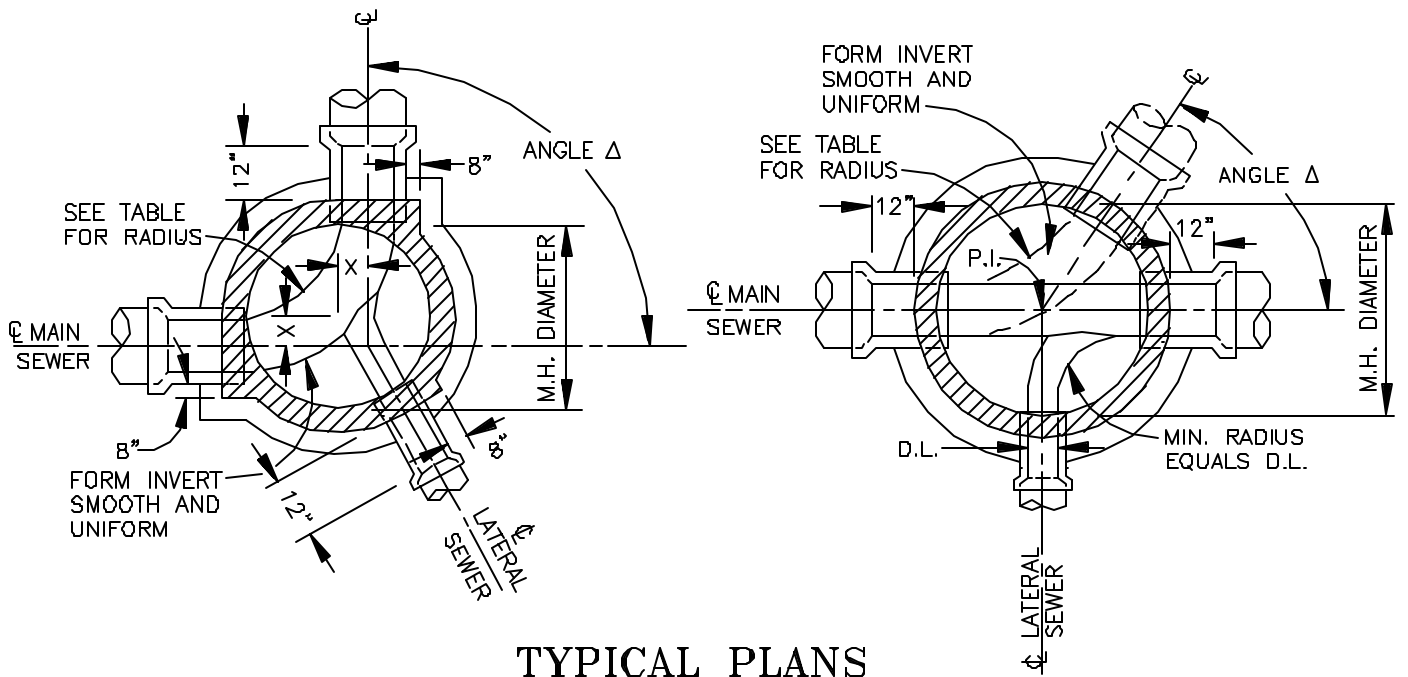

**TYPICAL PLANS  
STANDARD MANHOLE**

STANDARD MANHOLE SCHEDULE OF GOVERNING DIMENSIONS				
PIPE SIZE	ANGLE Δ	MANHOLE DIAMETER	"R"	"X"
8" TO 18"	0° TO 90°	4'-0"	2'-0"	0"
21" & 24"	0° TO 60°	4'-0"	2'-0"	6"
21" & 24"	60° TO 70°	5'-0"	2'-0"	6"
21" & 24"	70° TO 80°	5'-0"	2'-0"	7- 1/2"
21" & 24"	80° TO 90°	5'-0"	2'-0"	10- 1/2"
30" & 36"	0° TO 60°	5'-0"	3'-0"	8"
30" & 36"	60° TO 70°	6'-0"	3'-0"	10"
30" & 36"	70° TO 80°	6'-0"	3'-0"	13"
30" & 36"	80° TO 90°	6'-0"	3'-0"	16"
42"	0° TO 35°	6'-0"	3'-0"	3"
42"	35° TO 50°	6'-0"	6'-0"	6"
42"	50° TO 90°	7'-0"	6'-0"	0"
48" & 54"	0° TO 35°	6'-0" & 7'-0"	6'-0"	0"
48" & 54"	35° TO 90°	8'-0"	6'-0"	0"

<b>CHEROKEE COUNTY WATER &amp; SEWERAGE AUTHORITY</b>	<b>STANDARD MANHOLE PLANS</b>  CONSTRUCTION STANDARD	DATE:	FEB. '03	STANDARD NO.  <b>S706</b>
		APPROVED:		

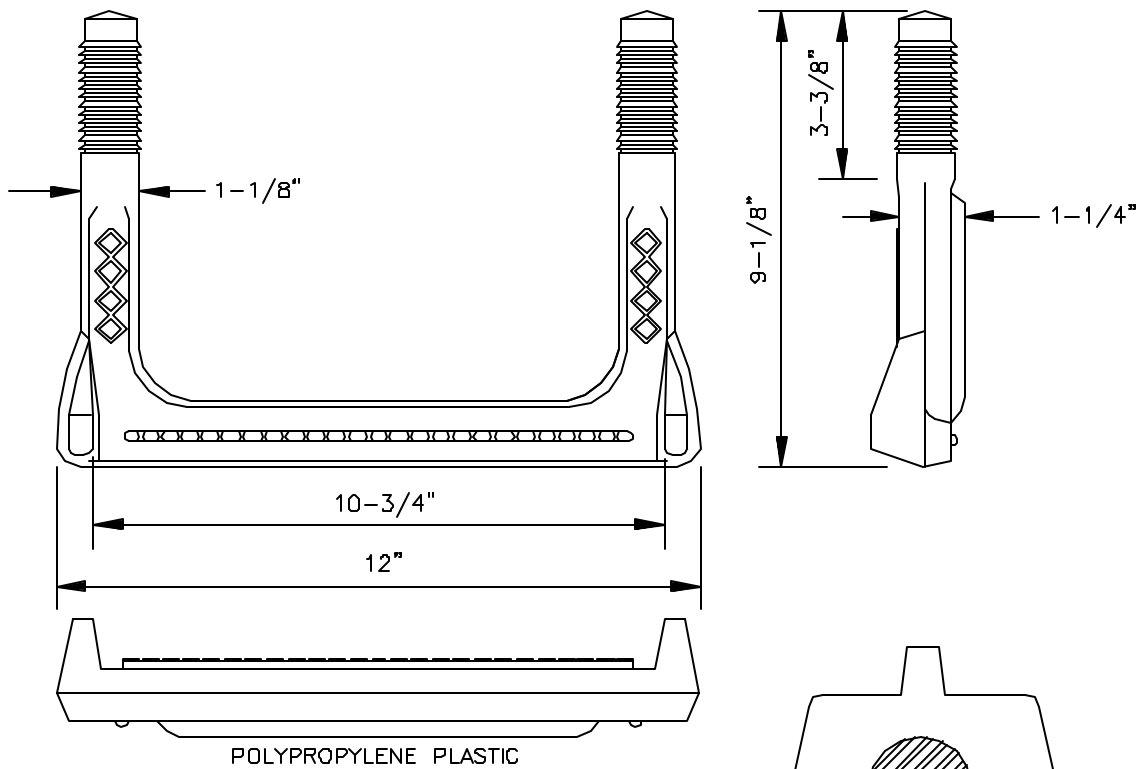

1/2" GRADE 60 STEEL REINFORCEMENT

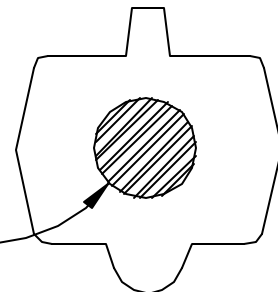

**SECTION**

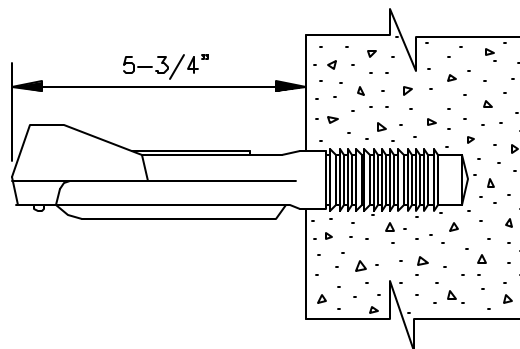

**MANHOLE STEP**  
**DETAIL**

**CHEROKEE COUNTY  
WATER & SEWERAGE  
AUTHORITY**

**MANHOLE  
STEP**  
CONSTRUCTION STANDARD

DATE:	FEB. '03
APPROVED:	

STANDARD  
NO.  
**S707**

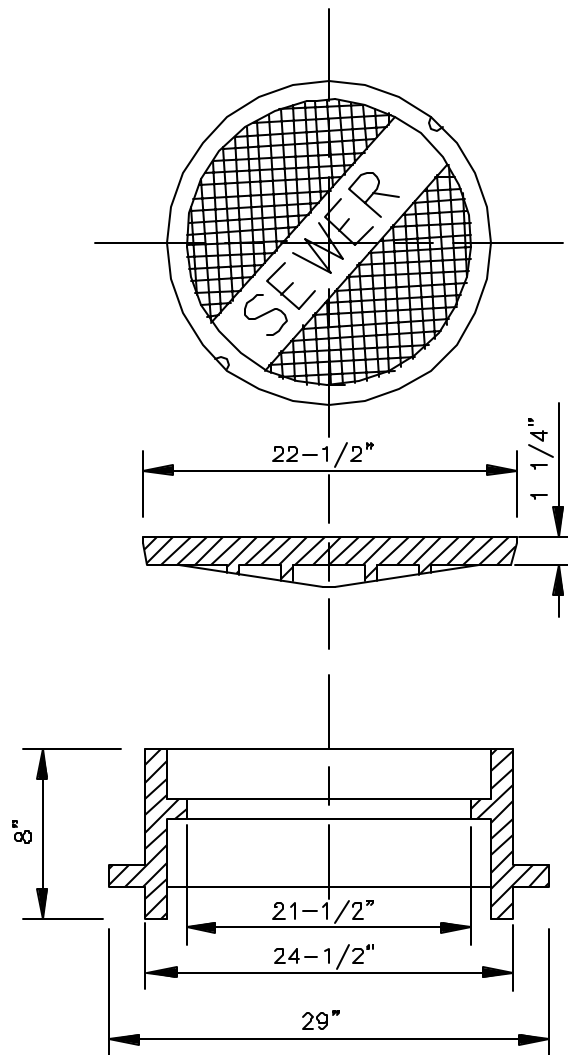

**MANHOLE FRAME AND COVER**

TOTAL WEIGHT: 315 LB.

NOTE: PICK HOLES SHALL NOT PENETRATE THE COVER.

<b>CHEROKEE COUNTY WATER &amp; SEWERAGE AUTHORITY</b>	<b>STANDARD MANHOLE FRAME &amp; COVER</b> CONSTRUCTION STANDARD	DATE:	FEB. '03	STANDARD NO. <b>S708</b>
		APPROVED:		



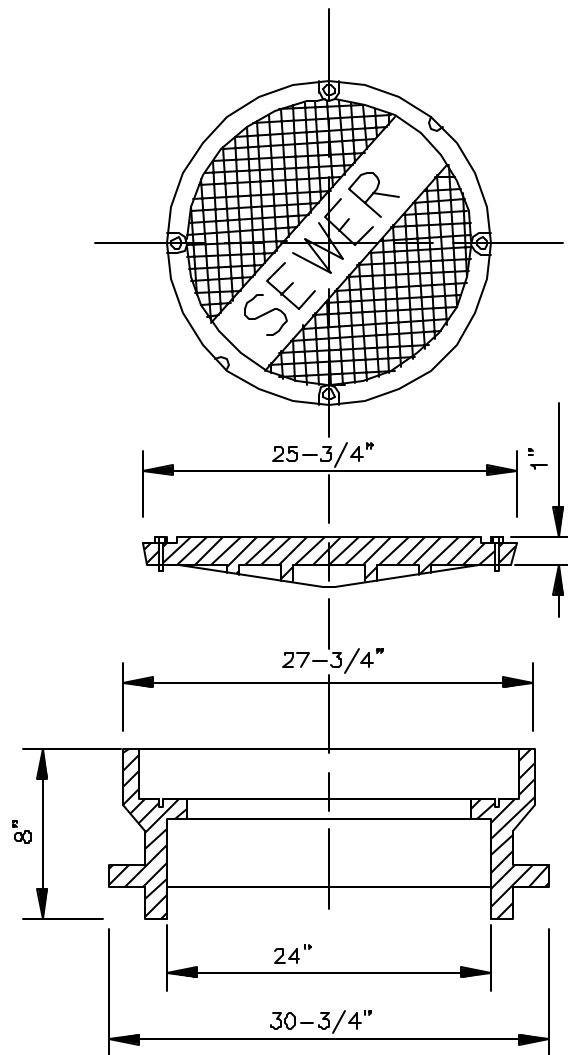

**WATER-TIGHT MANHOLE FRAME AND COVER**

TOTAL WEIGHT: 375 LB. WATER-TIGHT

NOTE: PICK HOLES SHALL NOT  
PENETRATE THE COVER.

<b>CHEROKEE COUNTY WATER &amp; SEWERAGE AUTHORITY</b>	<b>STANDARD MANHOLE FRAME &amp; COVER</b> CONSTRUCTION STANDARD	DATE:	FEB. '03	STANDARD NO. <b>S709</b>
		APPROVED:		

PLACE FOUR STEEL SHIMS (4" X 2") EQUALLY SPACED AROUND BOTTOM OF MH FRAME. THICKNESS SHALL BE AS REQUIRED TO MAKE COVER FLUSH WITH PAVEMENT. SURROUND SHIMS WITH CEMENT. WHEN THICKNESS IS LESS THAN 1/2", USE CONCRETE MORTAR INSTEAD. WHEN THICKNESS IS GREATER THAN 2", USE BRICKS. (NOT TO EXCEED 2 COURSES.)

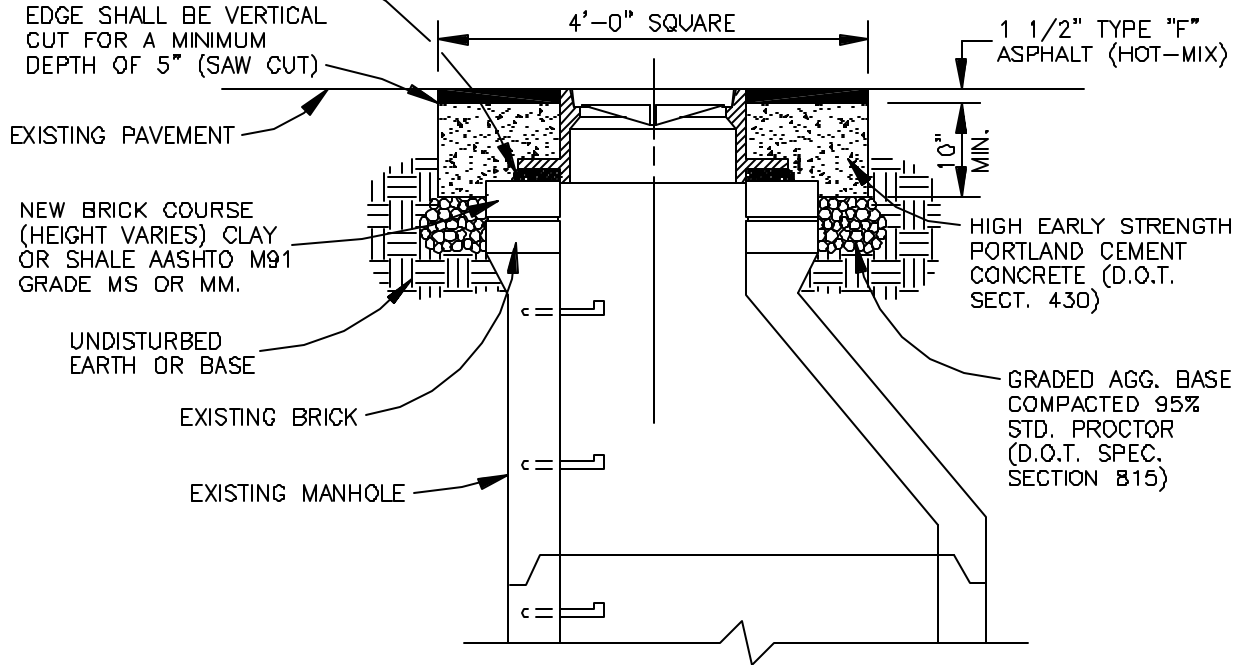

## MANHOLE FRAME-GRADE ADJUSTMENT

NOTES:

1. PORTLAND CONCRETE FOR COLLAR SHALL BE A MIN. OF 10" THICK AND SHALL EXTEND FROM THE LAST FULL COURSE OF BRICK TO 1 1/2" BELOW THE EXISTING PAVEMENT.
2. THE CONTRACTOR HAS THE OPTION OF USING PORTLAND CONCRETE FOR THE FULL DEPTH (FROM THE ASPHALT TO UNDISTURBED EARTH) OR AS SHOWN ABOVE.
3. THE CONCRETE SHALL BE LEFT WITH A RAKED FINISH TO PROVIDE A ROUGH SURFACE FOR THE ASPHALT TO BOND TO BITUMINOUS TACK AND ASPHALT SHALL BE PLACED PER CURRENT D.O.T. SPECIFICATIONS.
4. STEEL PLATES MAY BE REQUIRED BY THE AUTHORITY IN HIGH TRAFFIC AREAS TO PROTECT THE FRESH CONCRETE FOR A MINIMUM OF 40 HOURS. IN THESE HIGH TRAFFIC AREAS BARRICADES, CONES, ETC. WILL NOT BE ALLOWED.
5. BEFORE WORKING IN AN AREA, THE CONTRACTOR SHALL NOTIFY THE AUTHORITY.

**CHEROKEE COUNTY  
WATER & SEWERAGE  
AUTHORITY**

**MANHOLE  
FRAME-GRADE  
ADJUSTMENT  
CONSTRUCTION STANDARD**

DATE: FEB. '03

APPROVED:

STANDARD  
NO.  
**S710**

NOTE:

1. SEWER LATERAL TO BE LOCATED 10 FEET FROM THE SIDE LOT LINE ON THE DOWNSTREAM SIDE OF THE SANITARY SEWER.
2. MIN. SLOPE OF 1% REQ'D. FOR 6" SERVICE.

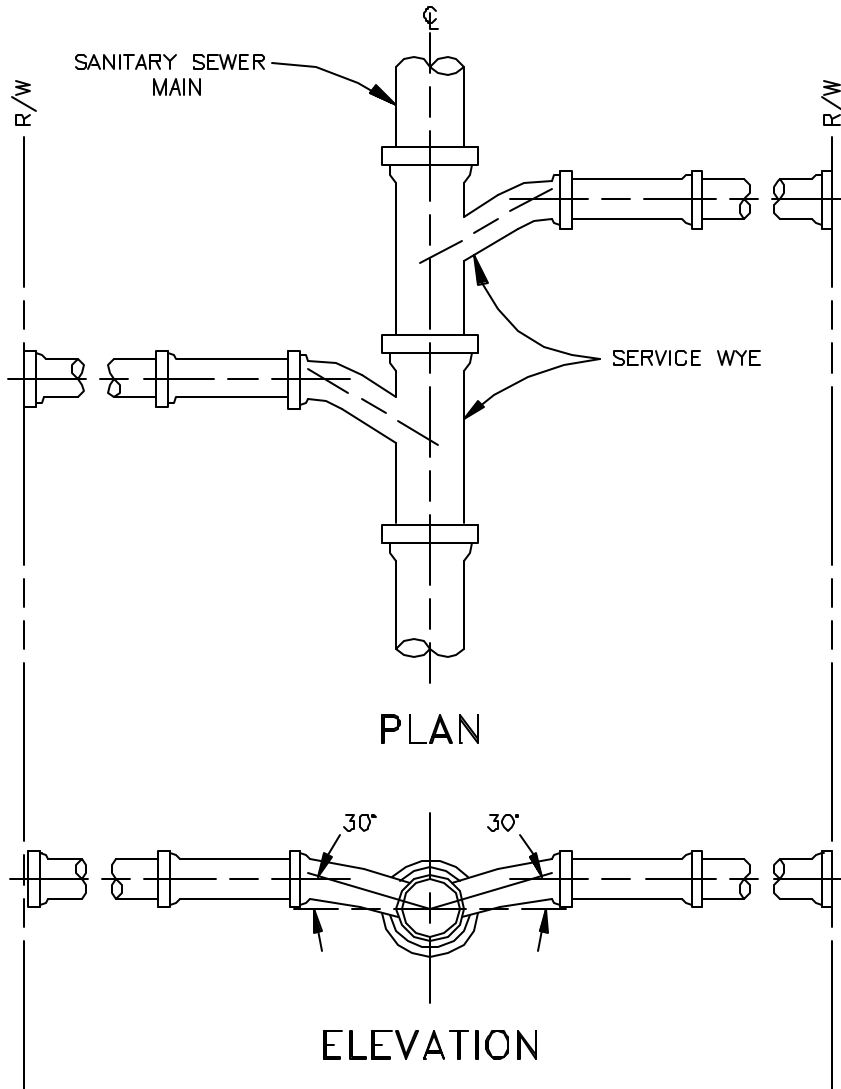

SEWER SERVICE LATERAL

**CHEROKEE COUNTY  
WATER & SEWERAGE  
AUTHORITY**

**SEWER SERVICE  
LATERAL**  
CONSTRUCTION STANDARD

DATE: FEB. '03

APPROVED:

STANDARD  
NO.  
**S711**

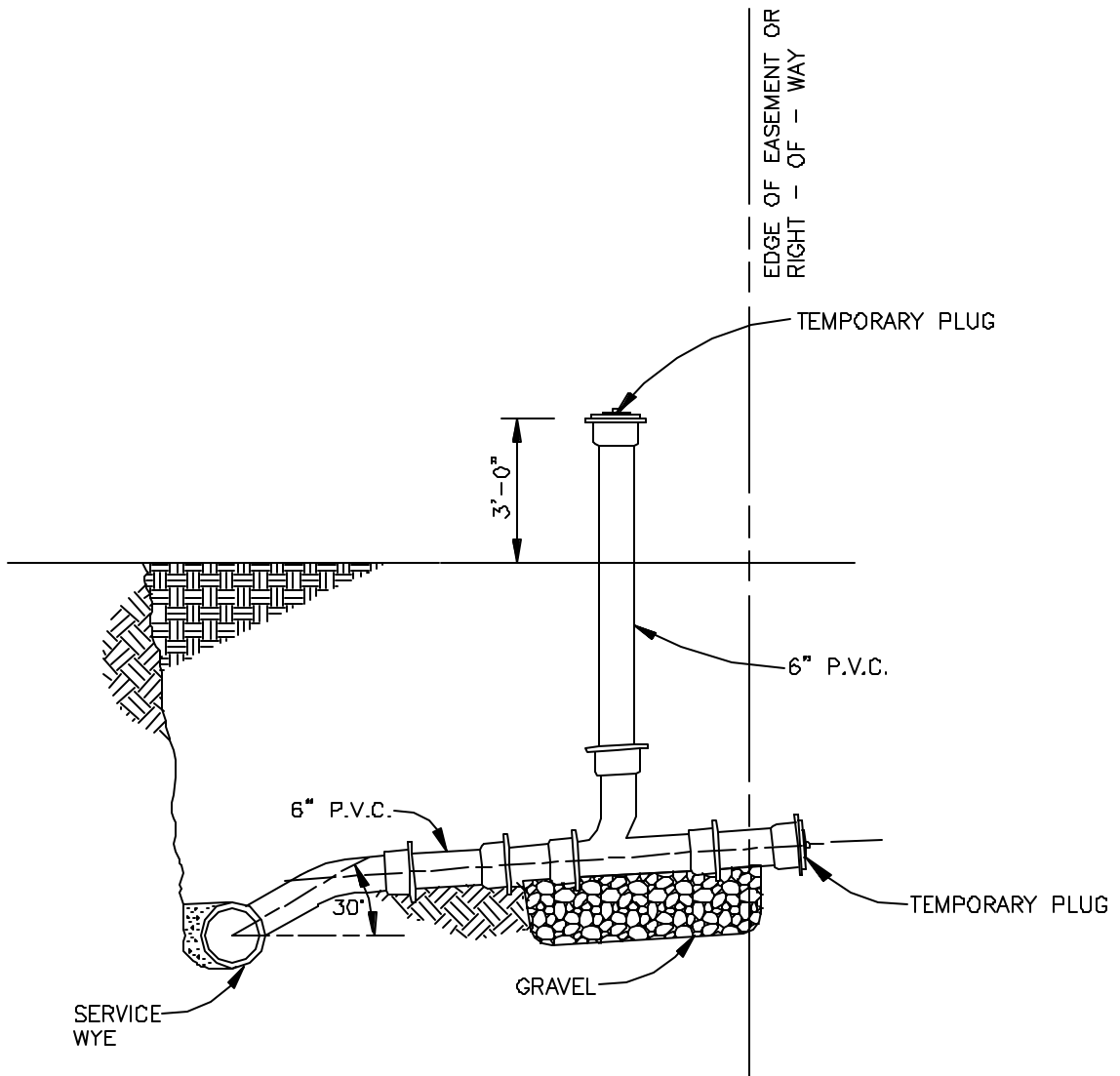

**SANITARY**  
**SEWER SERVICE**  
**LOCATION DETAIL**  
 (BY SEWER CONTRACTOR)

<b>CHEROKEE COUNTY WATER &amp; SEWERAGE AUTHORITY</b>	<b>SEWER SERVICE LOCATION DETAIL</b>  CONSTRUCTION STANDARD	DATE:	FEB. '03	STANDARD NO. <b>S712</b>
		APPROVED:		

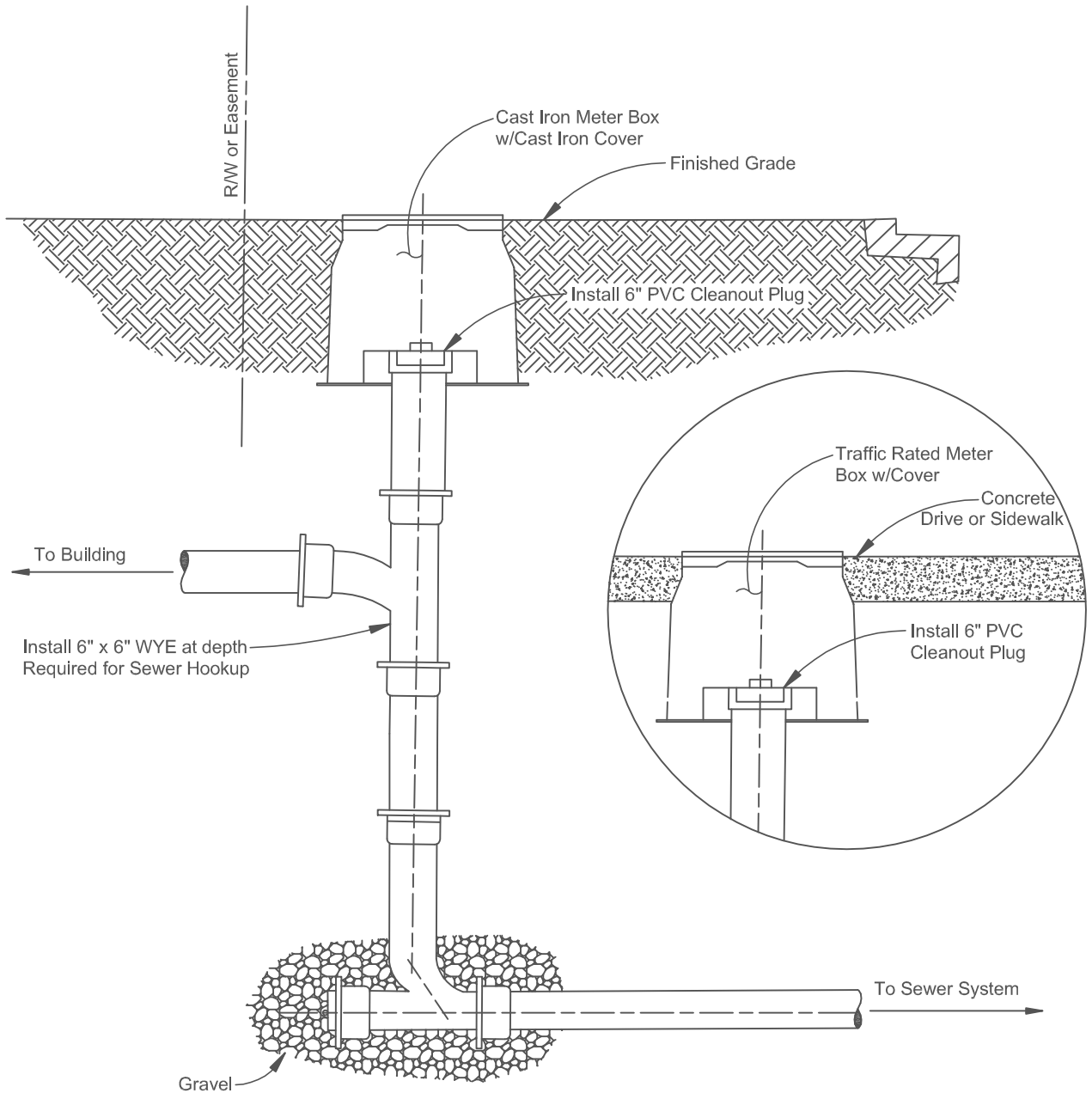

**CLEANOUT DETAIL**  
(BY BUILDER)

**Note:**

- 1.) If Meter Box/Cleanout is located in driveway or sidewalk. Meter Box and lid shall be traffic rated.
- 2.) Easement is required for Meter Box/Cleanout located outside of Right of Way.
- 3.) Meter Box shall be supported with compacted soil, gravel, etc. to keep top of box from settling below finished grade. Bricks can be used but shall not be placed on top of water lines.

<b>CHEROKEE COUNTY WATER &amp; SEWERAGE AUTHORITY</b>	<b>CLEANOUT DETAIL</b>  CONSTRUCTION STANDARD	DATE: MAR. '04	STANDARD NO.  <b>S713</b>
		Revised: June '13	
		APPROVED:	

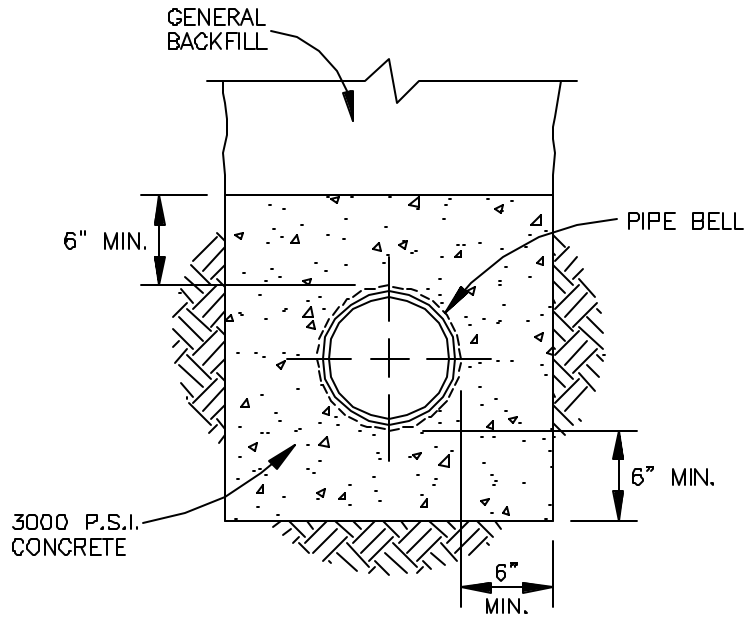

**CONCRETE ENCASEMENT**

<b>CHEROKEE COUNTY WATER &amp; SEWERAGE AUTHORITY</b>	<b>CONCRETE ENCASEMENT</b>  CONSTRUCTION STANDARD	DATE:	FEB. '03	STANDARD NO.  <b>S714</b>
		APPROVED:		

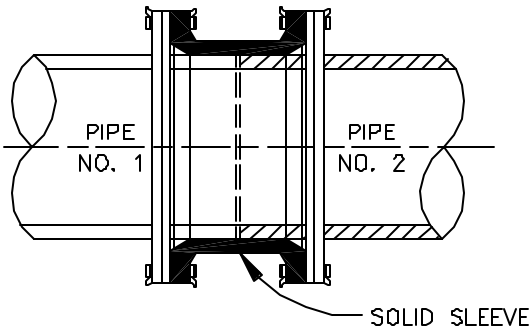

**PIPE ADAPTER**  
**JOINING DIFFERENT TYPES OF PIPE**

<b>CHEROKEE COUNTY WATER &amp; SEWERAGE AUTHORITY</b>	<b>TYPICAL PIPE ADAPTER</b>  CONSTRUCTION STANDARD	DATE:	FEB. '03	STANDARD NO. <b>S715</b>
		APPROVED:		

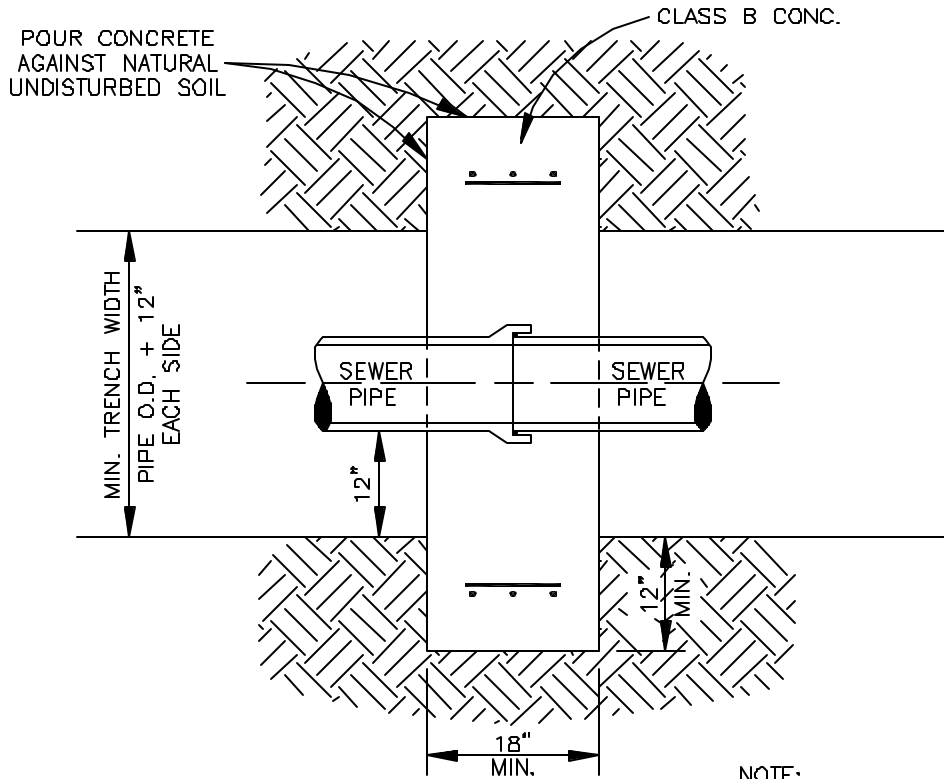

PLAN

NOTE:

1. COLLAR REQUIRED AT EVERY PIPE JOINT.

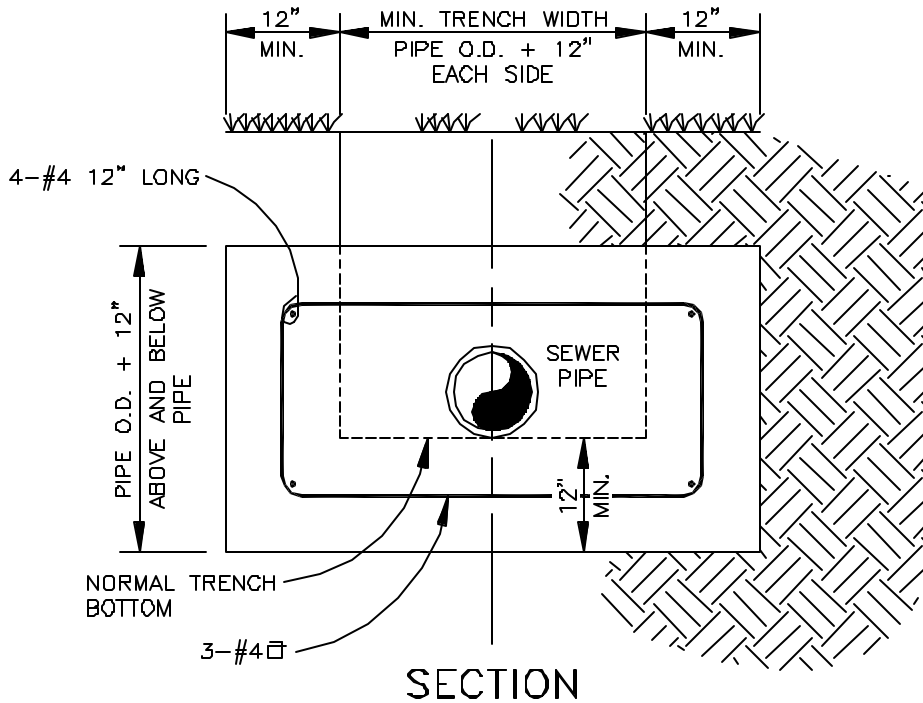

SECTION

SEWER PIPE ANCHOR

<b>CHEROKEE COUNTY WATER &amp; SEWERAGE AUTHORITY</b>	<b>SEWER PIPE ANCHOR</b> (SLOPES 20% OR MORE) CONSTRUCTION STANDARD	DATE:	FEB. '03	STANDARD NO. <b>S716</b>
		APPROVED:		



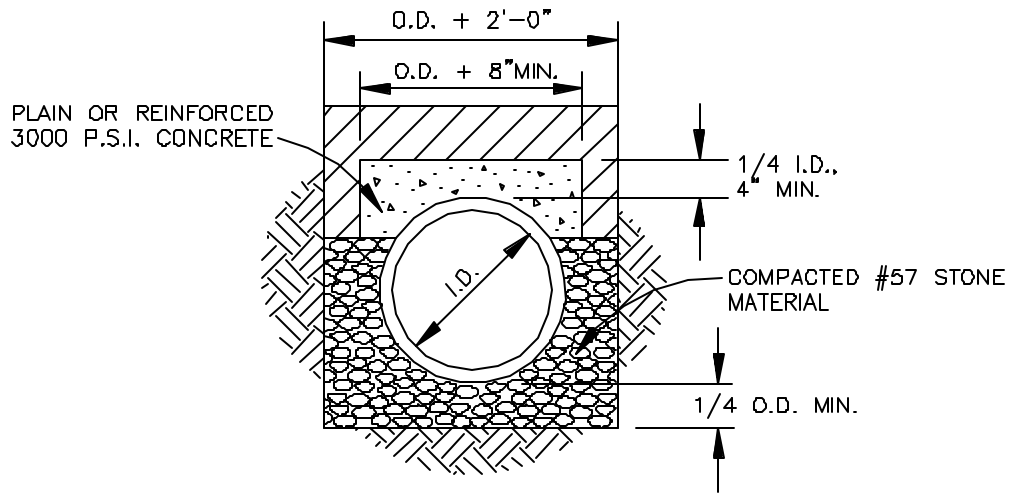

**CONCRETE ARCH**

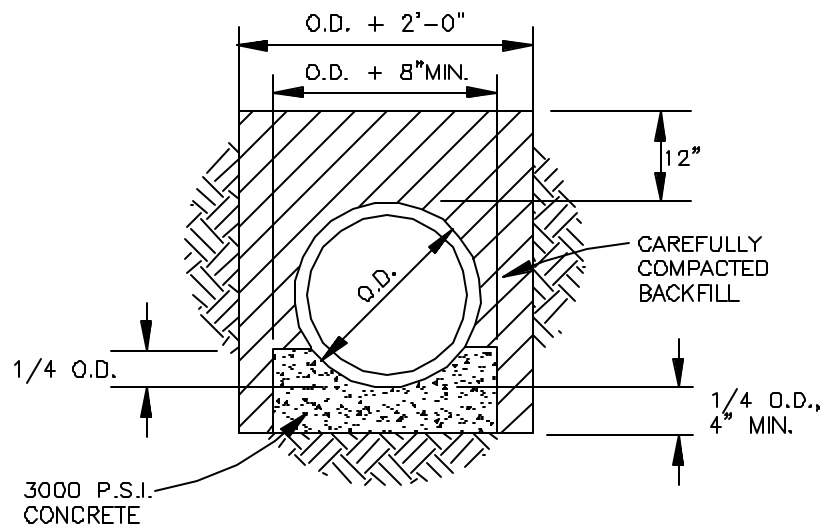

**CONCRETE CRADLE**

**CHEROKEE COUNTY  
WATER & SEWERAGE  
AUTHORITY**

**PIPE CLASS  
'A' BEDDING**  
CONSTRUCTION STANDARD

DATE:	FEB. '03
APPROVED:	

STANDARD  
NO.  
**S717**

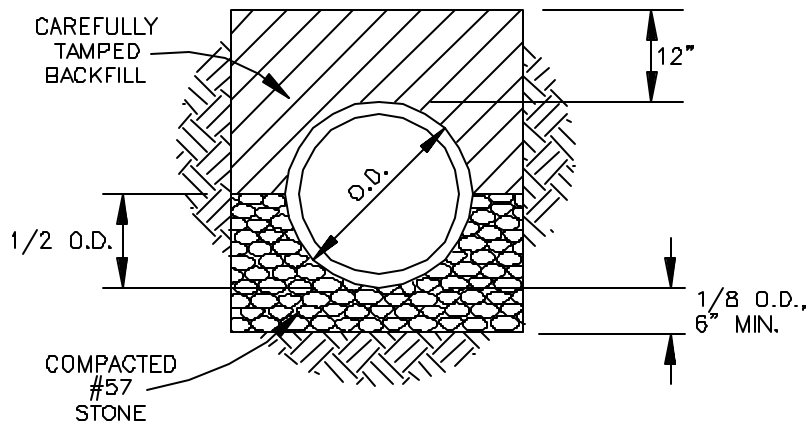

COMPACTED GRANULAR BEDDING  
LOAD FACTOR 1.9

PIPE CLASS 'B' BEDDING

<b>CHEROKEE COUNTY WATER &amp; SEWERAGE AUTHORITY</b>	<b>PIPE CLASS 'B' BEDDING</b> CONSTRUCTION STANDARD	DATE:	FEB. '03	STANDARD NO. <b>S718</b>
		APPROVED:		

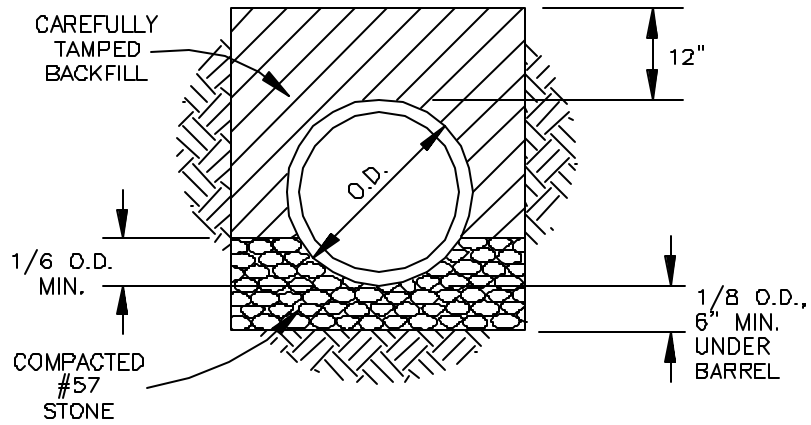

GRANULAR BEDDING  
LOAD FACTOR 1.5

PIPE CLASS 'C' BEDDING

<b>CHEROKEE COUNTY WATER &amp; SEWERAGE AUTHORITY</b>	<b>PIPE CLASS 'C' BEDDING</b> CONSTRUCTION STANDARD	DATE:	FEB. '03	STANDARD NO. <b>S719</b>
		APPROVED:		

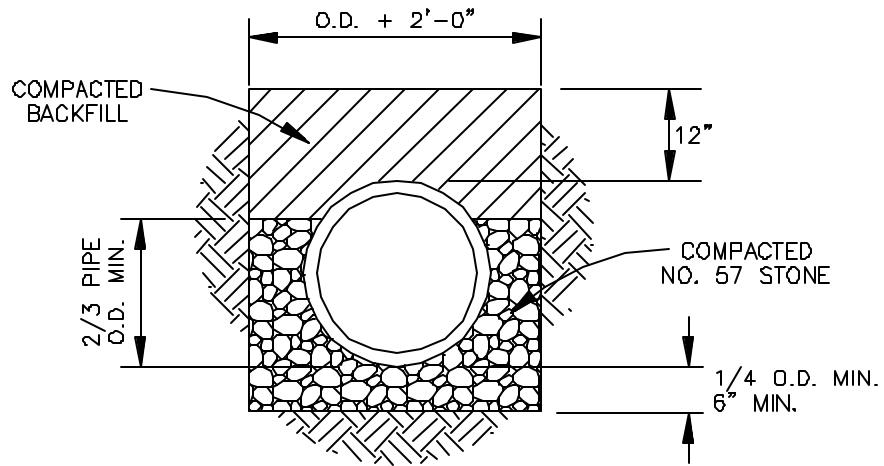

**MINIMUM P.V.C. PIPE  
BEDDING DETAIL**

NOT TO SCALE

NOTE: IF PVC SANITARY SEWER LINE IS CONSTRUCTED IN 100 YEAR FLOOD PLAIN OR BELOW GROUNDWATER TABLE, COMPACTED CLASS 1 MATERIAL IS REQUIRED TO THE TOP OF THE PIPE.

<b>CHEROKEE COUNTY WATER &amp; SEWERAGE AUTHORITY</b>	<b>MINIMUM P.V.C. PIPE BEDDING DETAIL</b> CONSTRUCTION STANDARD	DATE:	FEB. '03	STANDARD NO. <b>S720</b>
		APPROVED:		

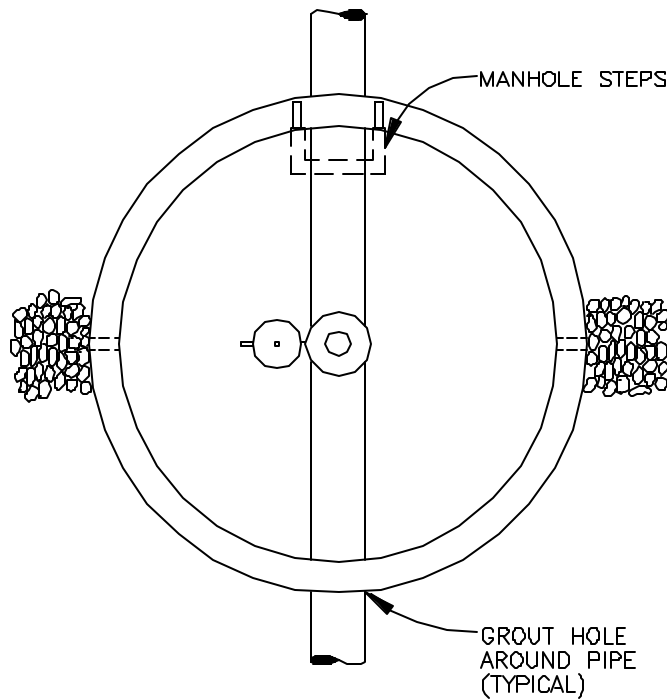

PLAN

**NOTES:**

1. NO PIPE JOINTS ALLOWED WITHIN MANHOLE.
2. ALL MANHOLES IN ROAD RIGHT-OF-WAY SHALL BE FLUSH WITH GRADE

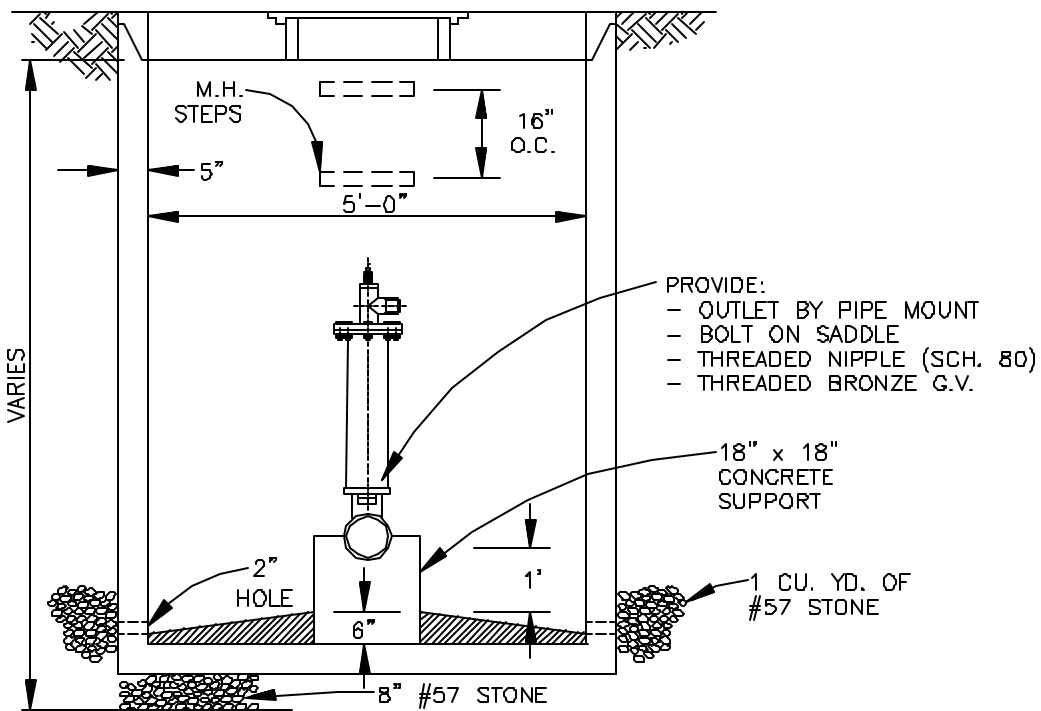

SECTION

**SEWER AIR & VACUUM VALVE ASSEMBLY**

<b>CHEROKEE COUNTY WATER &amp; SEWERAGE AUTHORITY</b>	<b>SEWER AIR &amp; VACUUM VALVE ASSEMBLY</b> CONSTRUCTION STANDARD	DATE: FEB. '03	STANDARD NO. <b>S721</b>
		APPROVED:	

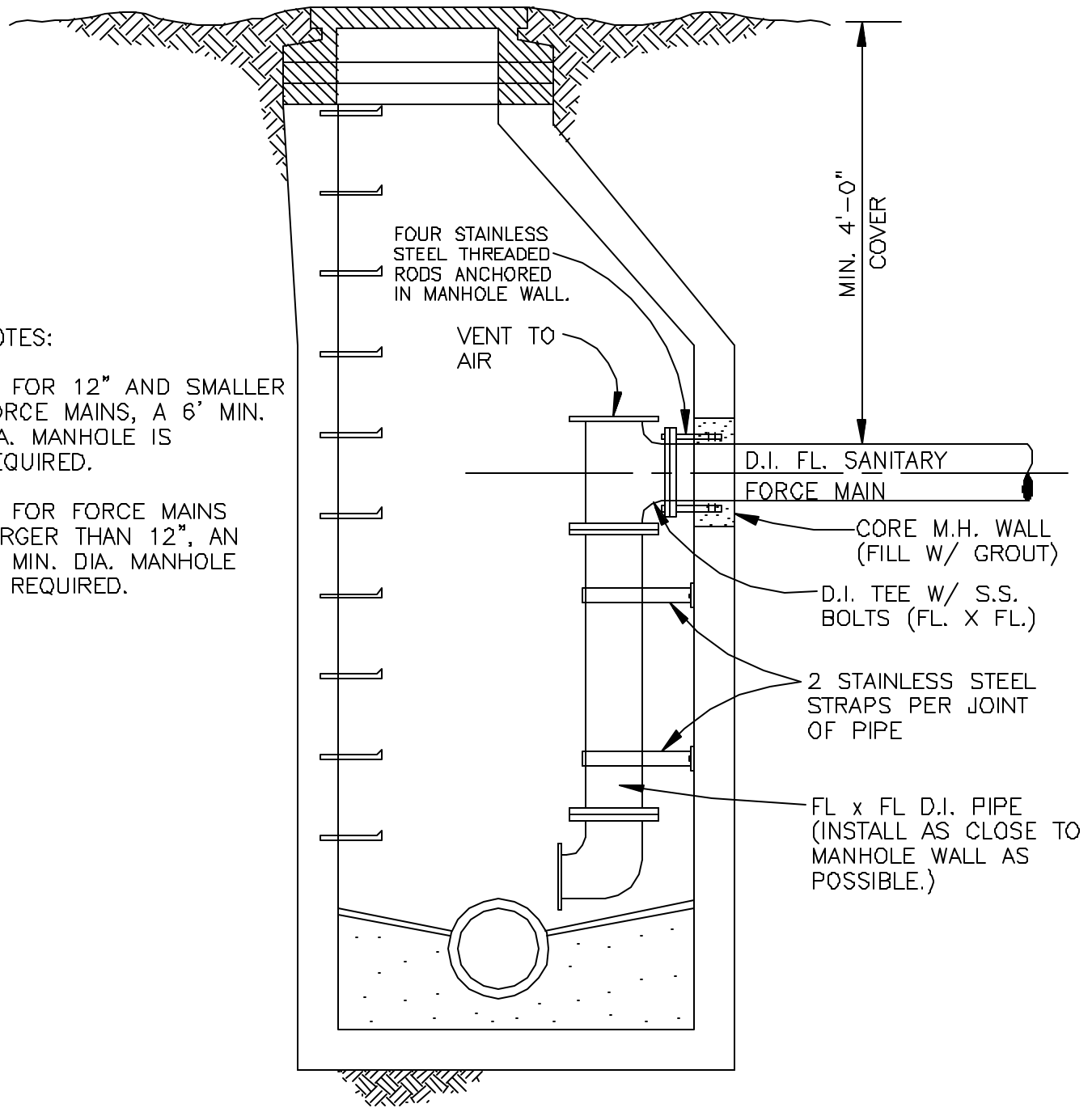

**NOTES:**

1. FOR 12" AND SMALLER FORCE MAINS, A 6' MIN. DIA. MANHOLE IS REQUIRED.

2. FOR FORCE MAINS LARGER THAN 12", AN 8' MIN. DIA. MANHOLE IS REQUIRED.

**FORCE MAIN CONNECTION TO EXISTING MANHOLE**

**CHEROKEE COUNTY  
WATER & SEWERAGE  
AUTHORITY**

**FORCE MAIN  
CONNECTION  
TO MANHOLE  
CONSTRUCTION STANDARD**

DATE: FEB. '03

APPROVED:

STANDARD  
NO.  
**S722**

GROUT ANNULAR SPACE  
BETWEEN CARRIER PIPE  
AND LINER

GROUT BETWEEN  
EARTH AND CASING

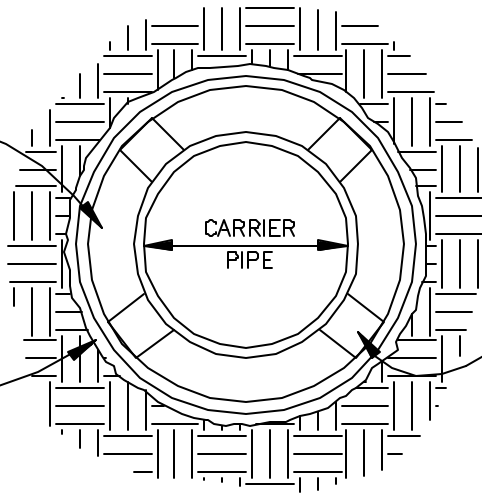

CASING SPACERS SHALL BE  
INSTALLED TO SECURE THE  
PIPE AT THE PROPER  
GRADE AND ELEVATION  
THROUGHOUT THE CASING  
AND TO PREVENT MOVEMENT  
OF THE PIPE DURING GROUTING.

**CASING SPACER DETAIL**

**CHEROKEE COUNTY  
WATER & SEWERAGE  
AUTHORITY**

**SEWER CASING  
SPACER DETAIL**  
CONSTRUCTION STANDARD

DATE: FEB. '03

APPROVED:

STANDARD  
NO.  
**S723**

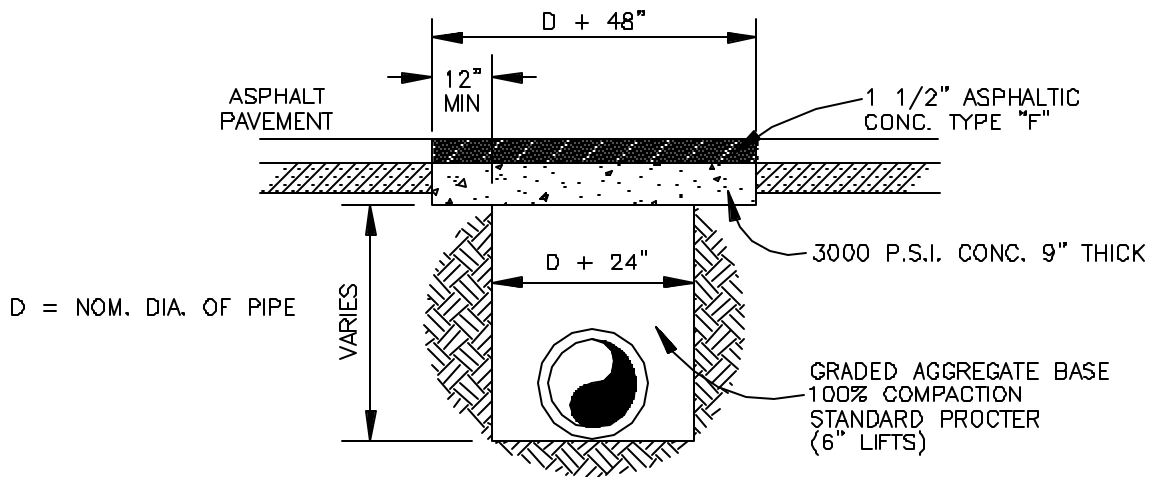

**STATE OR STATE-AID ROADS**

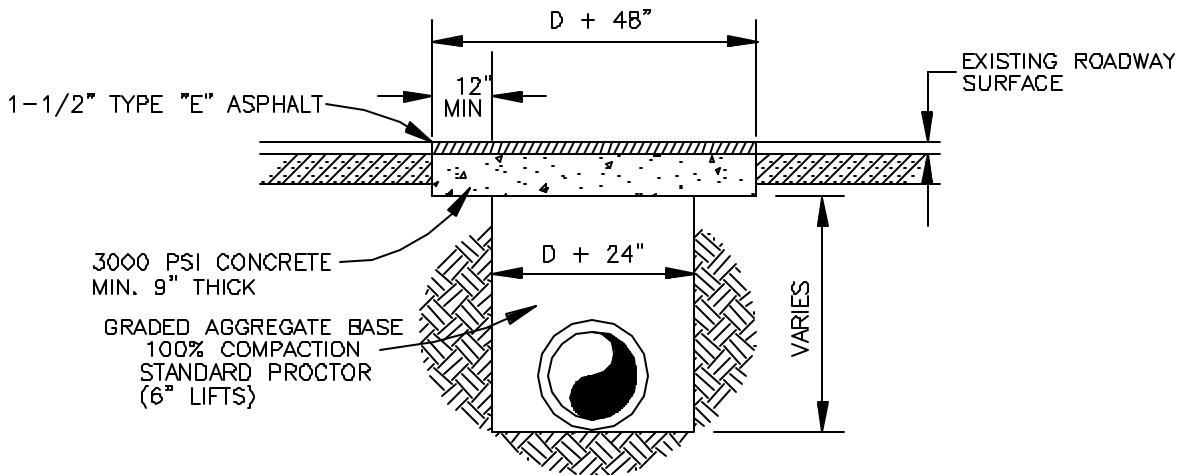

**NOTES:**

1. PERMISSION MUST BE OBTAINED FROM CHEROKEE COUNTY TO OPEN CUT EXISTING ROADS.
2. ROADWAYS WILL GENERALLY BE BORED OR TUNNELED FROM DITCH LINE TO DITCH LINE.
3. IF CONCRETE PAVEMENT, REPLACE WITH ORIGINAL THICKNESS (MINIMUM 8"), FLUSH WITH EXISTING PAVEMENT.

**COUNTY ROADS**

**CHEROKEE COUNTY  
WATER & SEWERAGE  
AUTHORITY**

**TYPICAL STREET  
CUT REPAIR**  
CONSTRUCTION STANDARD

DATE:	FEB. '03
APPROVED:	

STANDARD NO.  
**S724**



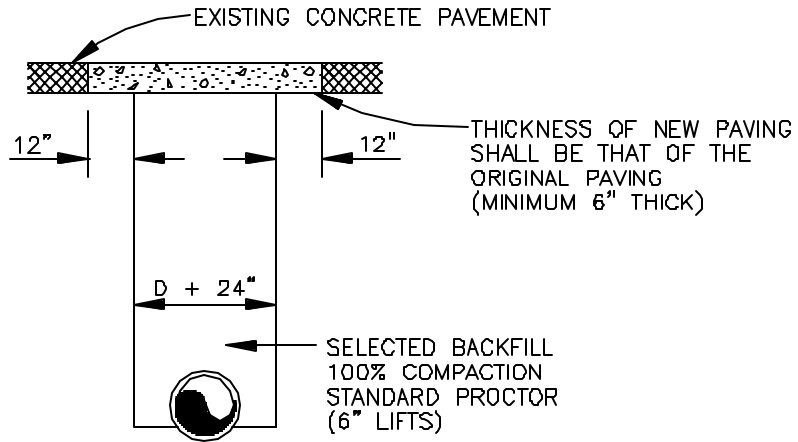

## CONCRETE DRIVEWAY

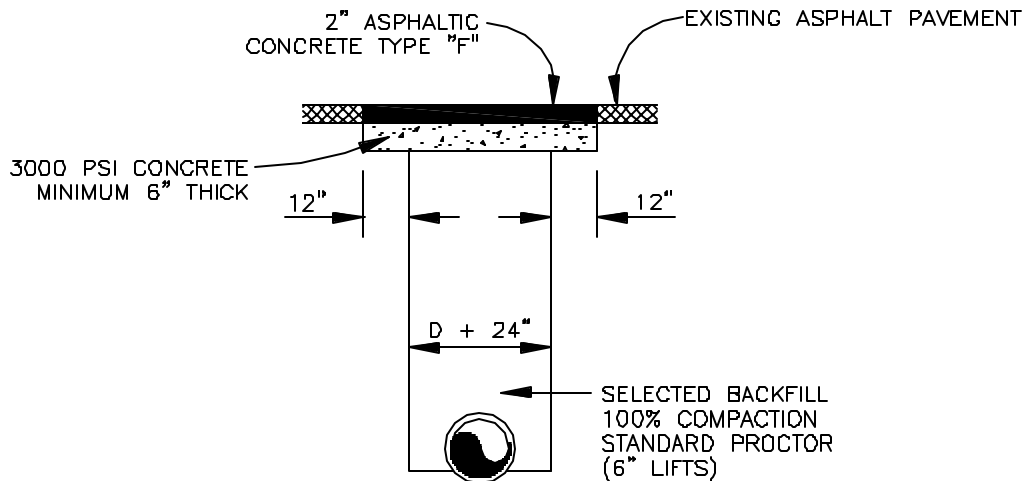

## ASPHALT DRIVEWAY

### NOTES:

1. BACKFILL TO BE COMPACTED AS DIRECTED IN SPECIFICATIONS.
2. D = NOMINAL PIPE DIAMETER

**CHEROKEE COUNTY  
WATER & SEWERAGE  
AUTHORITY**

**TYPICAL  
DRIVEWAY  
CUT REPAIR  
CONSTRUCTION STANDARD**

DATE: FEB. '03

APPROVED:

STANDARD  
NO.  
**S725**

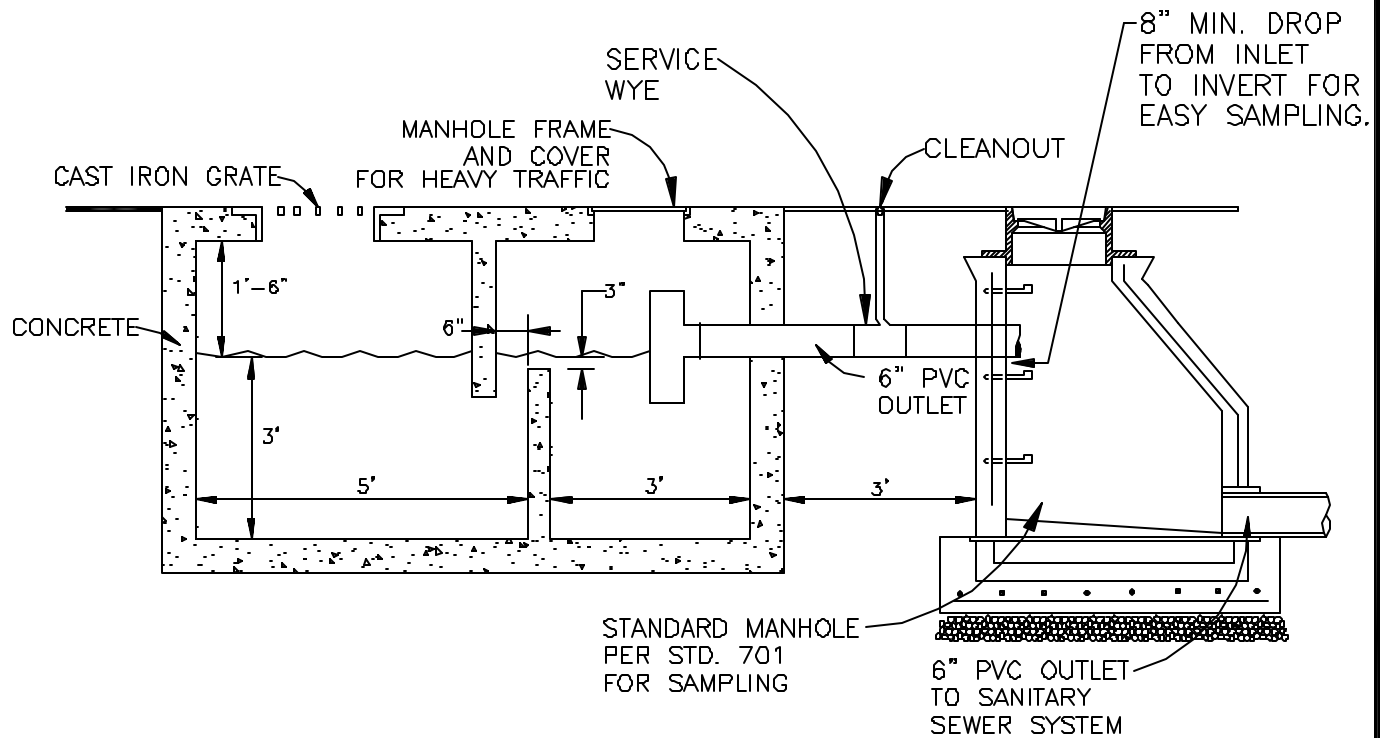

MINIMUM SIZE: 1,500 GALLONS

NOTE:  
 SIZE AND DIMENSIONS OF COMBINATION SAND/OIL TRAP AND PIPING  
 DEPENDENT ON QUANTITY OF FLOW. DESIGN ENGINEER  
 SHALL SUBMIT CALCULATIONS TO SUPPORT DESIGN SIZE.

**CHEROKEE COUNTY  
 WATER & SEWERAGE  
 AUTHORITY**

**TYPICAL  
 COMBINATION  
 SAND/OIL TRAP**  
 CONSTRUCTION STANDARD

DATE: FEB. '03

APPROVED:

STANDARD  
 NO.  
**S726**

CCWSA STANDARD 1500 GALLON GREASE TRAP

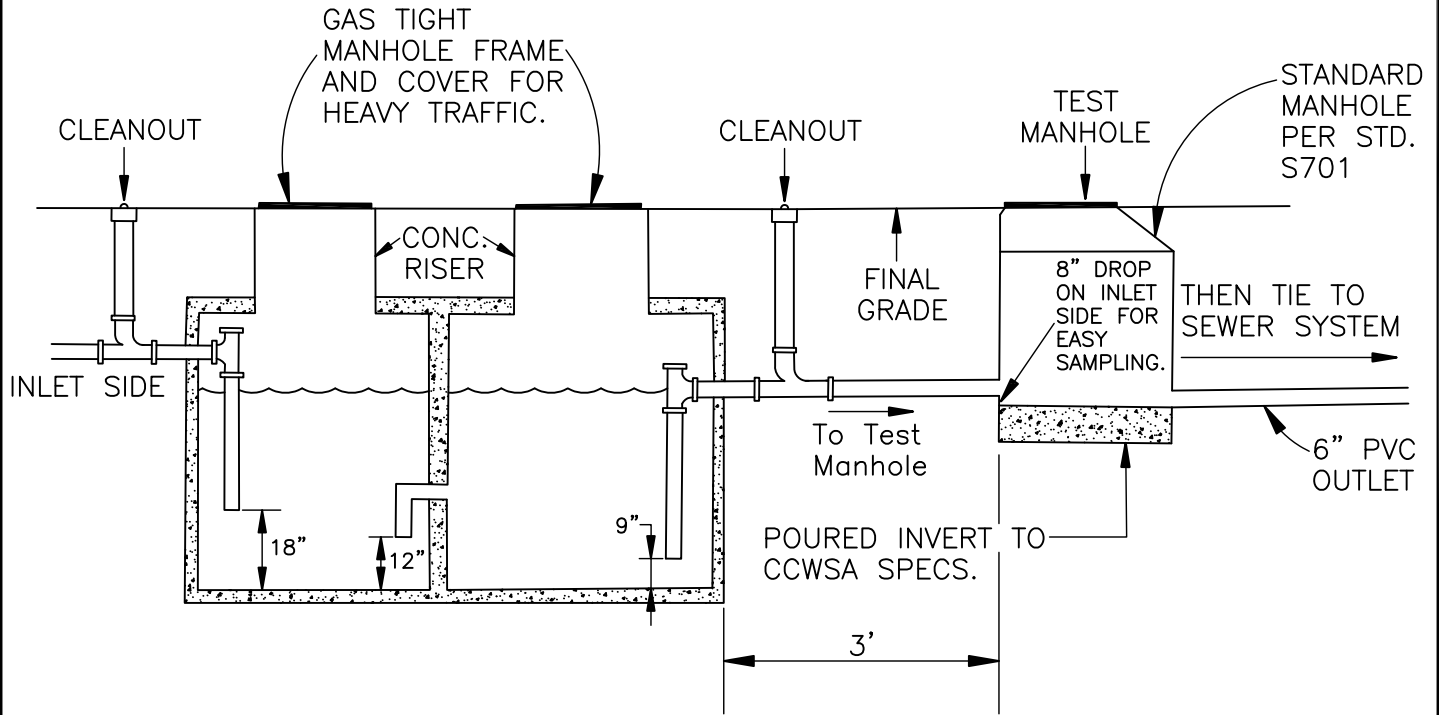

NOTES:

1. MIN. OF 4" P.V.C. Piping From Business To Test Manhole.
2. MIN. SIZE: 1,500 GALLONS  
Eating establishments/restaurants shall have a 1500 gallon grease trap for an occupancy of 75 seats or less. Eating establishments/restaurants shall have two (2) 1500 gallon grease traps in series for an occupancy of 76 seats or more. The Authority shall determine the size(s) and the number of grease traps for establishments/restaurants with more than 150 seats or 150 person occupancy. All grease traps shall be installed according to the Authority's Typical Grease Trap Detail. Authority approval shall be required for any connection varying from this.
3. Size And Dimensions of Grease Trap and Piping dependent on Flow from Restaurant. Designer shall submit Calculations to Support Design Size.
4. Only The Flow From The Grease Trap is Allowed To Enter The Test Manhole.
5. All Dumpsters Must be routed through the Inlet Side of The Grease Trap.
6. No Restroom Sewerage is Allowed to Flow Through the Grease Trap.

<b>CHEROKEE COUNTY WATER &amp; SEWERAGE AUTHORITY</b>	<b>TYPICAL GREASE TRAP</b>  CONSTRUCTION STANDARD	DATE: FEB. '03	STANDARD NO.  <b>S727</b>
		Revised July '14	
		APPROVED:	

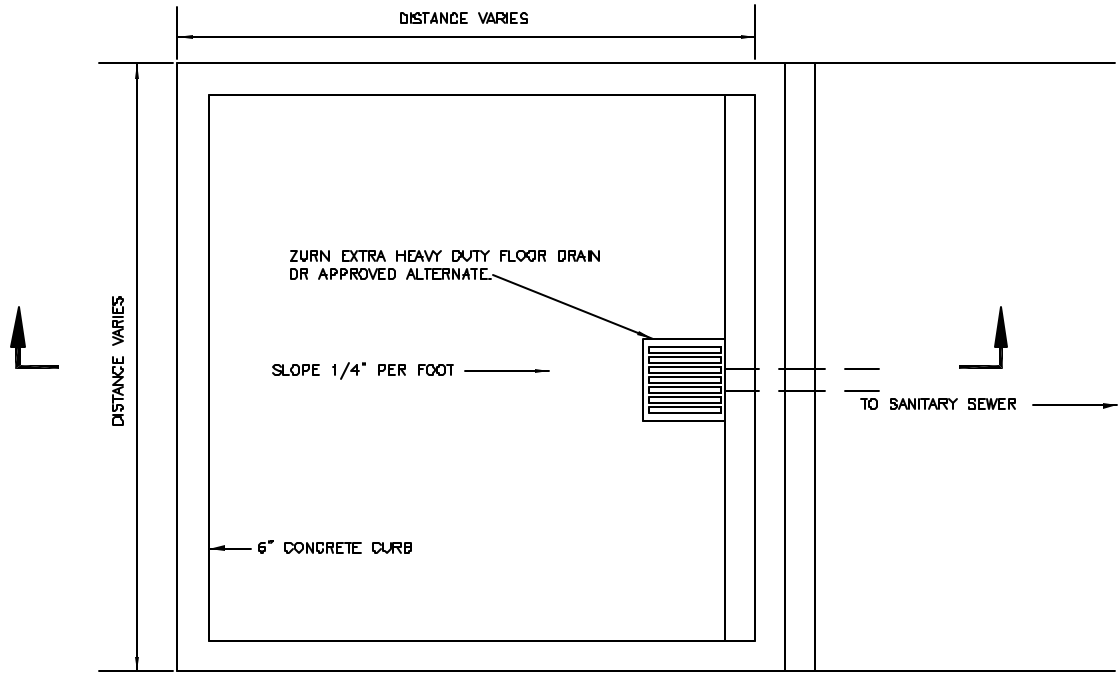

**PLAN VIEW**

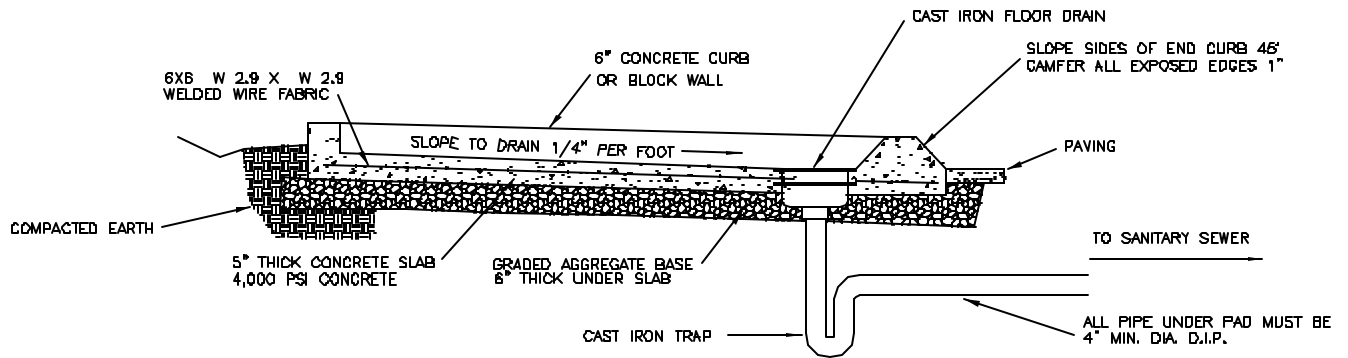

**SECTION VIEW**

NOTE: FLOW FROM DUMPSTER PAD SHALL BE ROUTED THROUGH GREASE TRAP IF APPLICABLE.

<b>CHEROKEE COUNTY WATER &amp; SEWERAGE AUTHORITY</b>	<b>DUMPSTER PAD DETAIL</b>  CONSTRUCTION STANDARD	DATE:	FEB. '03	STANDARD NO.  <b>S728</b>
		APPROVED:		

NOTES:

1. FLOOR OF CHECK VALVE VAULT TO BE SLOPED TO DRAIN WET WELL.
2. FLOOR DRAIN SHALL HAVE P-TRAP TO BLOCK GASES FROM WET WELL.
3. GENERATOR AND CONTROL PANEL TO BE FIELD LOCATED BY CCWSA.

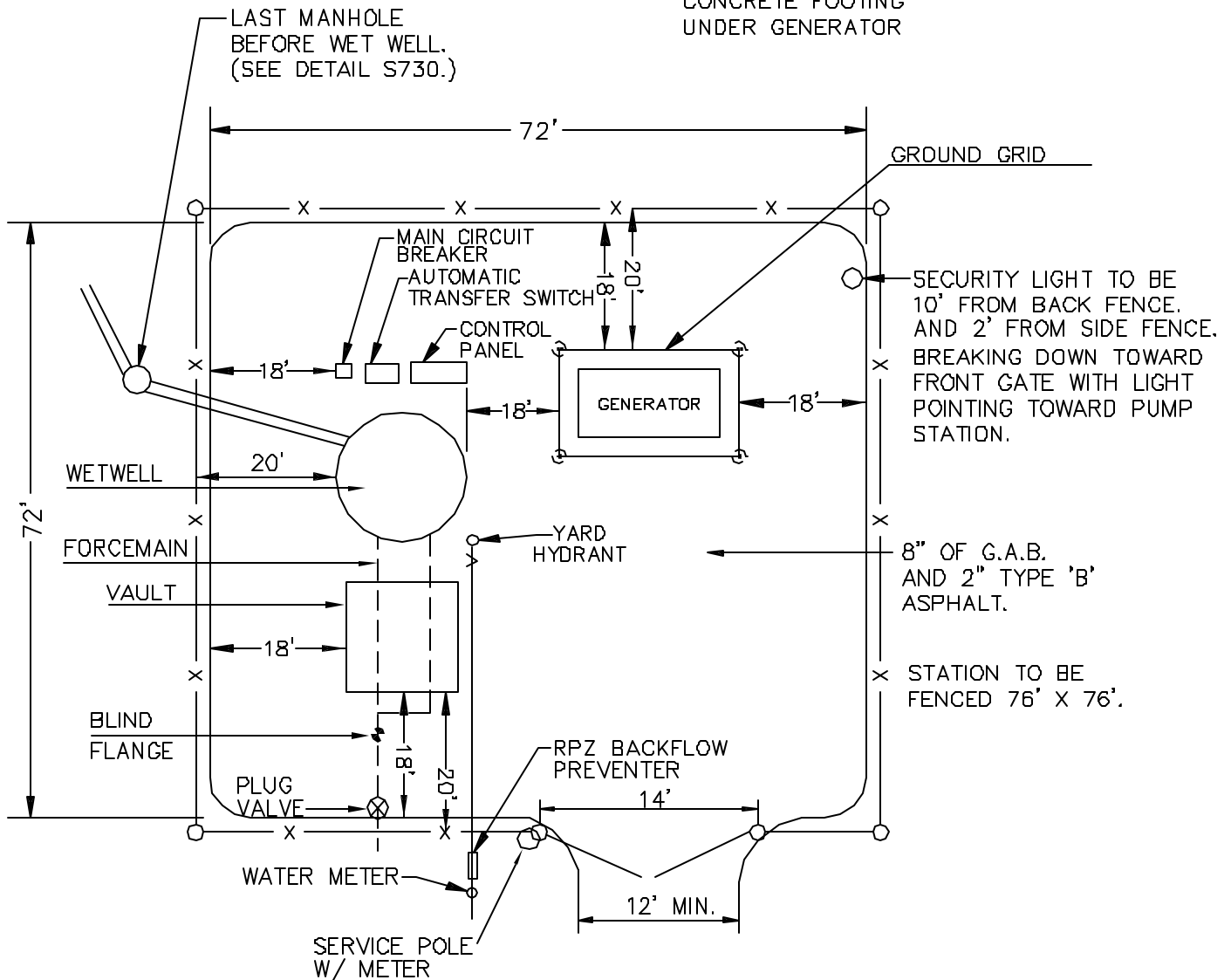
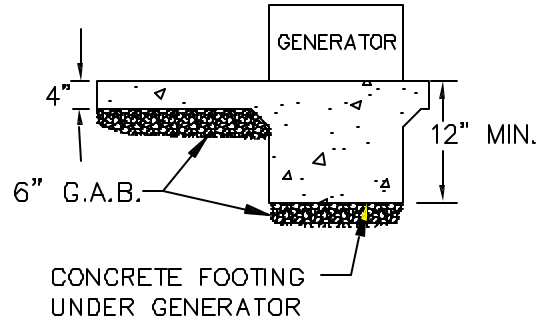

NOTE: THIS IS A GENERAL SCHEMATIC LAYOUT. LOCATIONS MAY VARY ACCORDING TO EQUIPMENT SIZE AND SITE REQUIREMENTS. NEED TO BE ABLE TO GET A TRUCK ON BOTH SIDES OF WET WELL AND GENERATOR. FOR DETAILED REQUIREMENTS, SEE SECTION 319 OF SANITARY SEWER STANDARDS.

<b>CHEROKEE COUNTY WATER &amp; SEWERAGE AUTHORITY</b>	<b>SUBMERSIBLE SITE LAYOUT PLAN</b> CONSTRUCTION STANDARD	DATE: FEB. '03	STANDARD NO. <b>S729</b>
		APPROVED: _____	

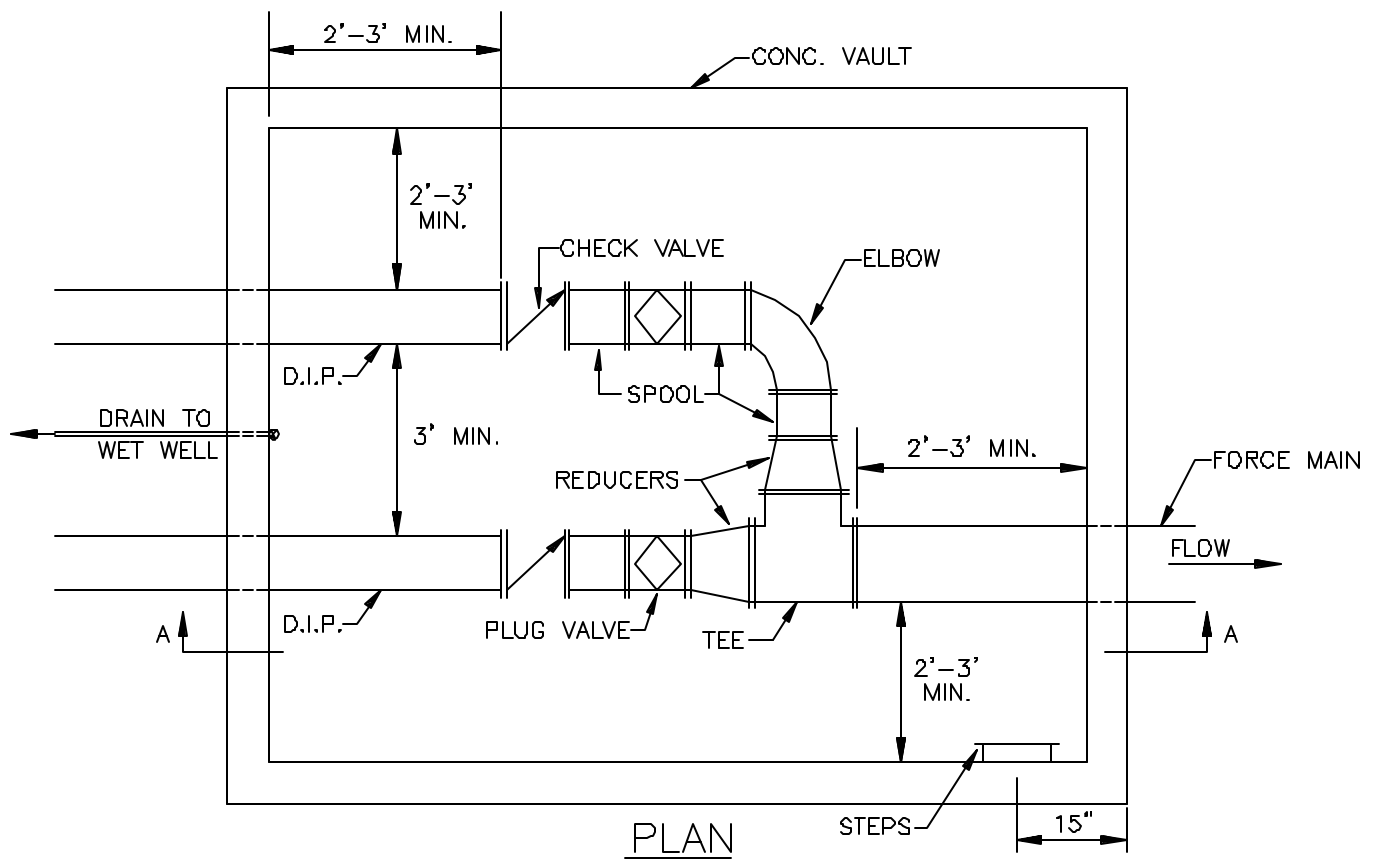

PLAN

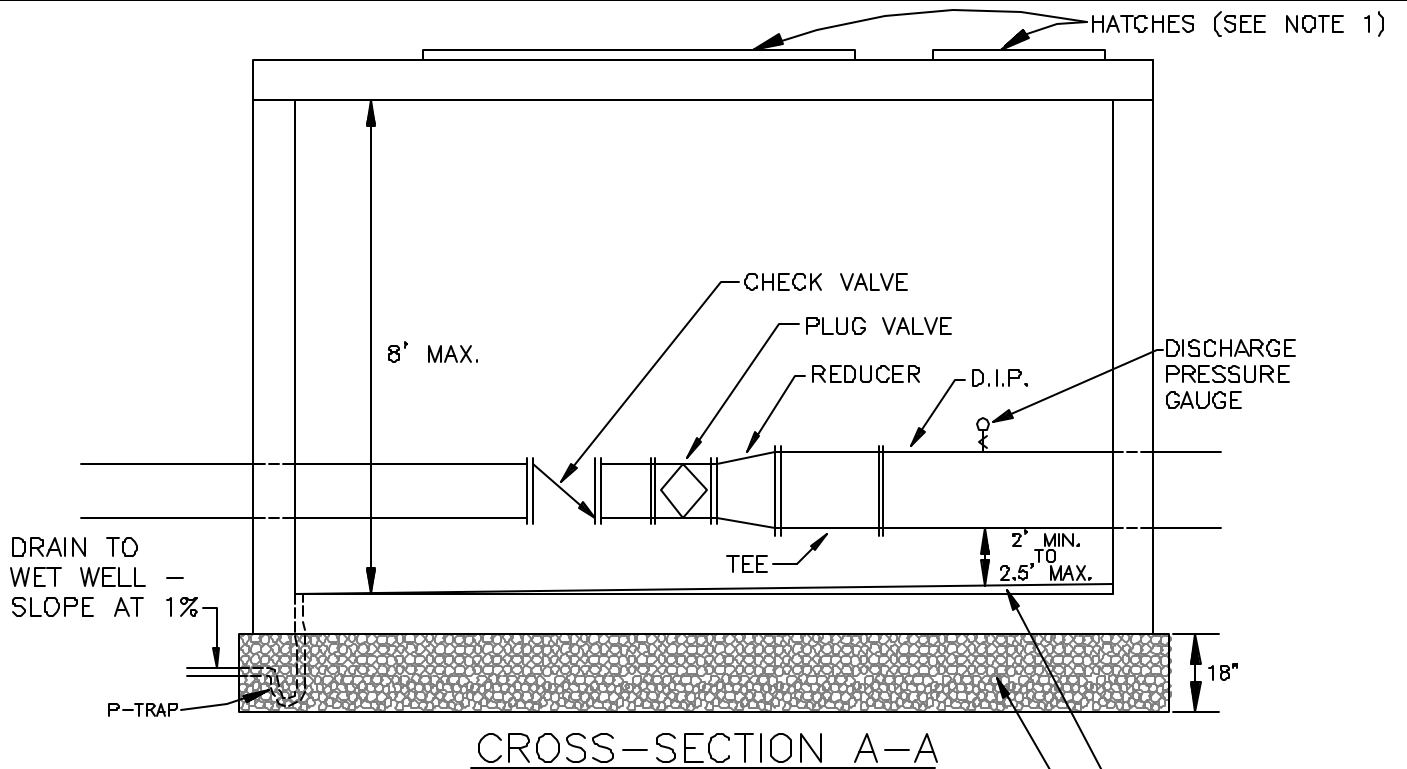

CROSS-SECTION A-A

NOTES:

1. HATCH OPENINGS INTO VAULT SHALL BE APPROVED BY THE CCWSA.
2. PIPE SUPPORTS REQ'D. UNDER ALL VALVES, TEES AND BENDS.
3. ALL VALVES AND FITTINGS SHALL BE FL. X FL.
4. SURGE RELIEF VALVE MAY BE REQ'D. DOWNSTREAM OF THE TEE DEPENDING UPON OPERATING PRESSURE OF THE SYSTEM.

GROUT SLOPE AT 2%  
#57 STONE  
NON-YIELDING  
FOUNDATION

**CHEROKEE COUNTY  
WATER & SEWERAGE  
AUTHORITY**

**LIFT STATION  
VALVE PIT DETAIL**  
CONSTRUCTION STANDARD

DATE:	FEB. '03
APPROVED:	

STANDARD  
NO.  
**S731**

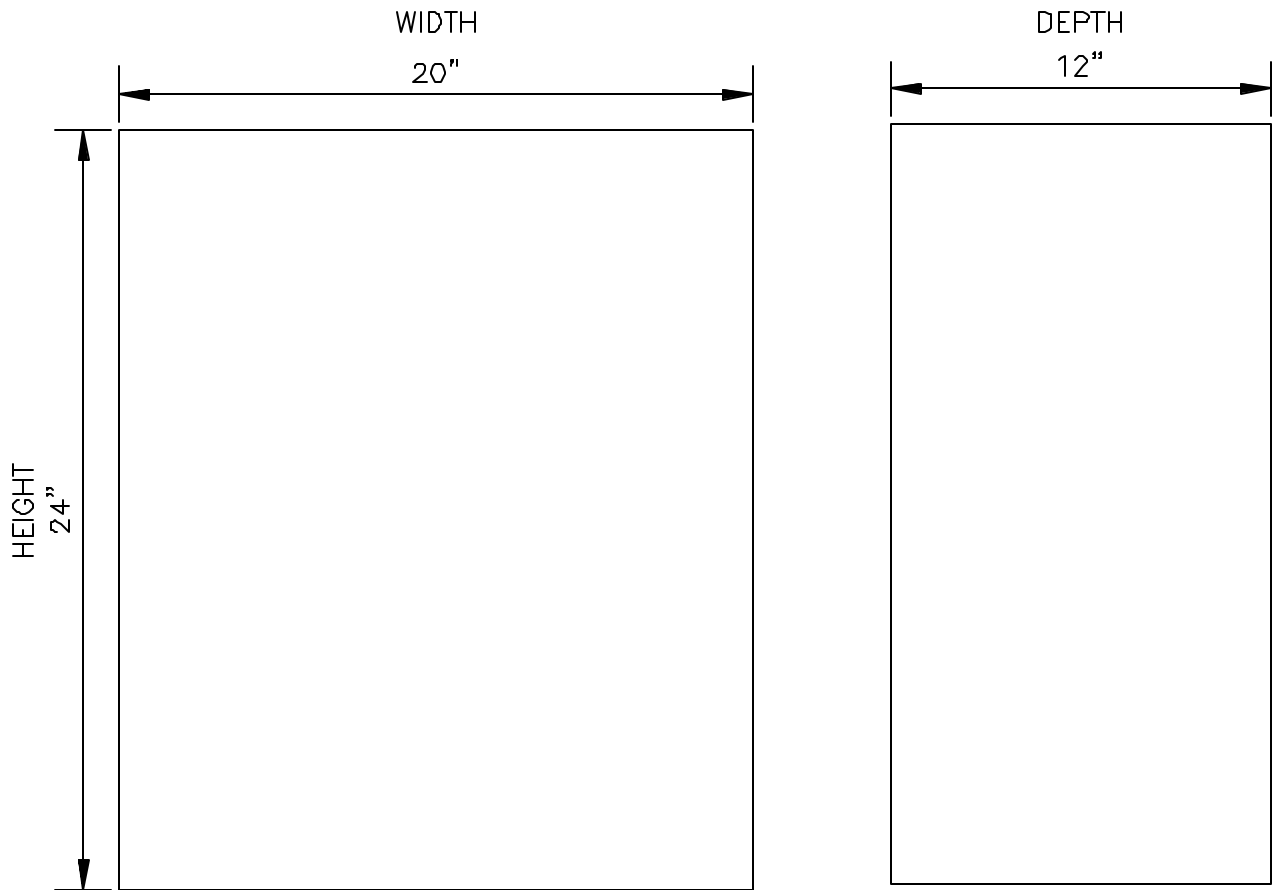

ROOM NEEDED IN CONTROL PANEL FOR SCADA

<b>CHEROKEE COUNTY WATER &amp; SEWERAGE AUTHORITY</b>	<b>SCADA RTU PANEL</b> CONSTRUCTION STANDARD	DATE:	FEB. '03	STANDARD NO. <b>S732</b>
		APPROVED:		

GROUND CONDUCTOR  
IN 3/4" CONDUIT.  
SIZE PER N.E.C.

#2 BARE STRANDED COPPER  
CONDUCTOR (TYPICAL)

GROUND GRID 24"  
BELOW GRADE

TO MAIN  
CIRCUIT  
BREAKER  
ENCLOSURE

GENERATOR  
ON CONCRETE  
PAD

3/4"Øx10'  
COPPERWELD  
GROUND ROD  
(TYP. FOR 4)

CADWELD ALL  
CONNECTIONS (TYP.)

**CHEROKEE COUNTY  
WATER & SEWERAGE  
AUTHORITY**

**PUMP STATION  
GROUNDING**

CONSTRUCTION STANDARD

DATE: FEB. '03

APPROVED:

STANDARD  
NO.

**S733**



CHEROKEE COUNTY  
 UTILITY PLACEMENT DETAIL 208-A  
 RURAL STREET SECTION  
 SEE ATTACHMENT "A"



CALL BEFORE YOU DIG  
 1-800-282-7411

DRAWING  
 (NOT TO SCALE)

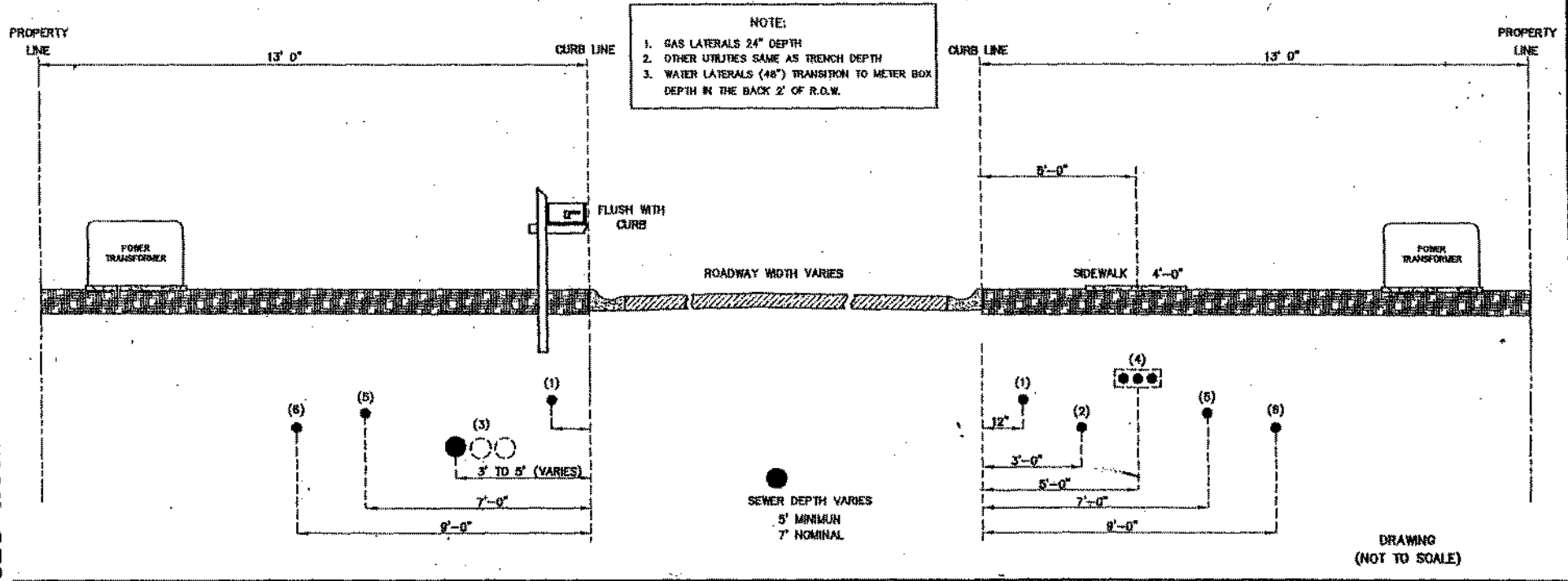

DRAWING  
 (NOT TO SCALE)

CCWSA DETAIL S734

<p>(1) CATV CURB DIST. - 1' DEPTH - 24" BOTH SIDES ROADWAY</p>	<p>(2) GAS CURB DIST. - 3' DEPTH - 36" EAST OR NORTH SIDE OF STREET AS DETERMINED AT SUBD. ENTRANCE</p>	<p>(3) WATER CURB DIST. - 3' TO 5' DEPTH - 48" WEST OR SOUTH SIDE OF STREET AS DETERMINED AT SUBD. ENTRANCE</p>	<p>(4) MULTI-DUCT CONDUIT CURB DIST. - 5' DEPTH - 18" REQUIRES SPECIAL PERMIT</p> <p>UTILITIES PROTECTION CENTER                  1-800-282-7411      METRO (770) 823-4344</p>	<p>(5) TELEPHONE CURB DIST. - 7' DEPTH - 30" BOTH SIDES OF ROAD JOINT TRENCH LOCATION FOR: TELEPHONE, CATV</p>	<p>(6) POWER CURB DIST. - 9' DEPTH - 36" BOTH SIDES OF ROAD JOINT TRENCH LOCATION FOR: PWR. TELE. CATV</p>	<p>NOTE: THE BACK (4) FEET OF THE R.O.W. IS RESERVED FOR THE PLACEMENT OF POLES, PEDESTALS, PULL BOXES, METERS, AND OTHER UTILITY DEVICES.</p>
--	---	---	--	--	--	--

# CHEROKEE COUNTY UTILITY PLACEMENT DETAIL 208-B RURAL STREET SECTION SEE ATTACHMENT "A"



CALL BEFORE YOU DIG  
1-800-282-7411

**NOTE:**  
NO UNDER-GROUND UTILITIES TO BE  
INSTALLED PRIOR TO ROADWAY AND SLOPE GRADING

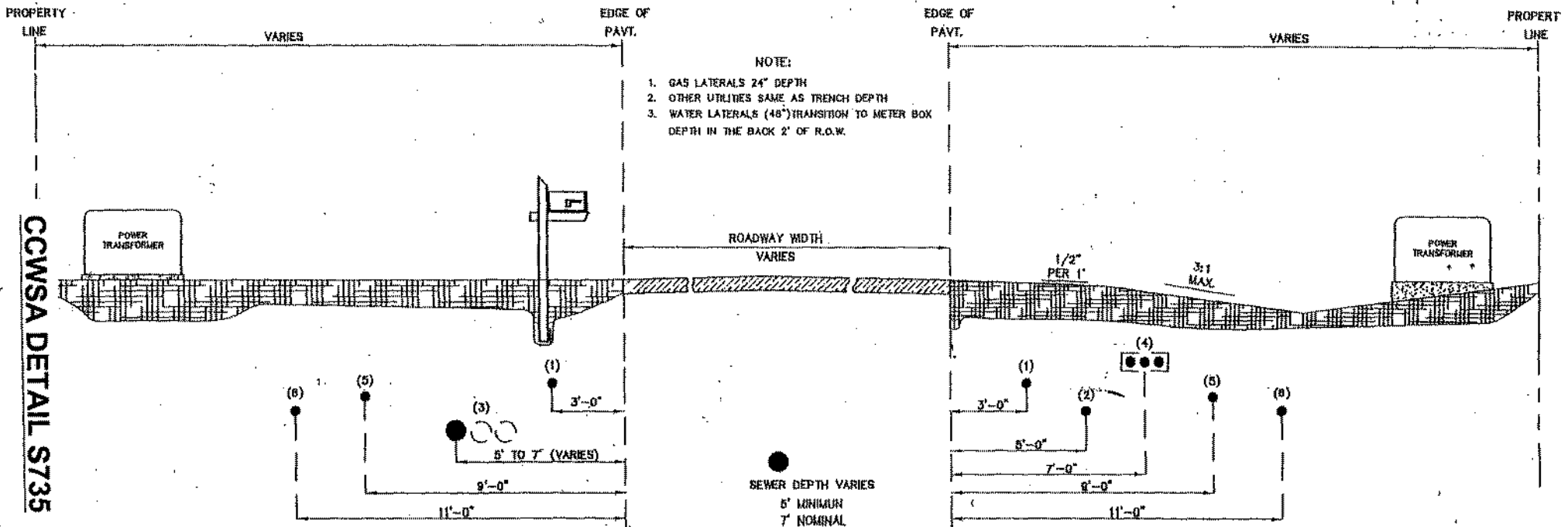

CCMSA DETAIL S735

<p>(1) CATV PAVT. DIST. - 3' DEPTH - 24" BOTH SIDES ROADWAY</p>	<p>(2) GAS PAVT. DIST. - 5' DEPTH - 36" EAST OR NORTH SIDE OF STREET AS DETERMINED AT SUBD. ENTRANCE</p>	<p>(3) WATER PAVT. DIST. - 5' TO 7' DEPTH - 48" WEST OR SOUTH SIDE OF STREET AS DETERMINED AT SUBD. ENTRANCE</p>	<p>(4) MULTI-DUCT CONDUIT PAVT. DIST. - 7' DEPTH - 18" REQUIRES SPECIAL PERMIT</p> <p style="text-align: center;">UTILITIES PROTECTION CENTER 1-800-282-7411      METRO (770) 623-4344</p>	<p>(5) TELEPHONE PAVT. DIST. - 9' DEPTH - 30" BOTH SIDES OF ROAD JOINT TRENCH LOCATION FOR: TELEPHONE, CATV</p>	<p>(6) POWER PAVT. DIST. - 11' DEPTH - 36" BOTH SIDES OF ROAD JOINT TRENCH LOCATION FOR: PWR. TELE. CATV</p>	<p><b>NOTE:</b> THE BACK (4) FEET OF THE R.O.W. IS RESERVED FOR THE PLACEMENT OF POLES, PEDESTALS, PULL BOXES, METERS, AND OTHER UTILITY DEVICES.</p>
---	--	--	--	---	--	---

**Detail S736**  
***Cherokee County Water & Sewerage Authority***

P.O. Box 5000 Canton, Georgia 30114  
Phone: (770) 479-1813 Fax: (770) 704-0053

**New Project Requirement Detail (2010)**

This is a list of some of the requirements that need to be met before obtaining water and/or sewer service in Cherokee County.

- A pre-construction meeting with water and/or sewer contractor and C.C.W.S.A inspector before work begins. (770) 479-9107
- Contractor must have approved plans stamped by C.C.W.S.A before water or sewer work begins.
- There are certain fees, depending on type of project, which must be paid to C.C.W.S.A. before getting service. Some of which are:

**Water Flow Test \$400.00**  
(Fees must be paid before test can be ordered)  
**Plan Review Fees:**  
**Water \$250.00**  
**Sewer \$500.00**  
**Lift Station \$10,000.00**  
***(FEES ARE SUBJECT TO CHANGE)***

Water Meter Deposit (Depends on size of meter and/or number of units.)

Back-Flow Device (Depends on size and type), when testable device is required we also must have test result by approved tester before setting of meter. Contact: Greg Long (770) 479-9107 ext. 228

Sewer Tap Fee (depends on size and type) Contact: Ricky Dobbs (770) 479-1813 ext 249

- If meter is larger than 2" meter must have a by-pass.(All fees paid before tapping)
- Must submit six sets of Plans & Electronic Data (On State Plane Coordinates) to Rose Creek Plant for all proposed projects. Contact: Jeff Hooper or Corey Ghorley (770) 591-7156

All sanitary sewer manholes in streets shall be required to be @ 95% compaction under the first foot of top grade. Compaction tests shall be at all 4' lifts on 2 sides of each manhole within a 2' diameter of the manhole. Test results shall be faxed to C.C.W.S.A. Inspection Department before any G.A.B. shall be placed on sub-grade.

C.C.W.S.A. Fax: (770) 704-0053  
(This applies to county projects only. Not projects within city limits)

If the proposed project will serve, or has the potential to serve a business that is required to have a grease trap or dumpster pad, plans for the same will be submitted to C.C.W.S.A. Inspection Department: Marty Rodgers (770) 479-9107 ext. 223

- Any and all final tests on water and sewer, and all fees paid, before final plat can be signed or release of meters.
- Three sets of each water & sewer as-built drawings for our records.
- Once job is released, owner/developer will be responsible for one year warranty period.
- Must be two separate signature places on final plat for C.C.W.S.A. to sign off.
- Project will not be released for meter sales until C.C.W.S.A. Inspection Department has received two copies of recorded final plat.
- At end of one year re-inspection will be done.
- If water has to be cut off, work needs to be scheduled 4 to 5 days ahead of time. Phone: (770) 479-9107
- CANNOT ENCROACH ON ANY BUFFERS, OWNER/DEVELOPER & ENGINEER WILL BE RESPONSIBLE FOR OBTAINING VARIANCES.(Must have in writing where variance was obtained)

Signature \_\_\_\_\_ Date \_\_\_\_\_



# CERTIFICATE OF LIABILITY INSURANCE

DATE (MM/DD/YYYY)  
01/01/2010

<b>PRODUCER</b>  Insurnce Agent/Broker Name Insurnce Agent/Broker Street Address or P.O. Box Insurnce Agent/Broker City, State & Zip Code Contact & Phone Number	<b>THIS CERTIFICATE IS ISSUED AS A MATTER OF INFORMATION ONLY AND CONFERS NO RIGHTS UPON THE CERTIFICATE HOLDER. THIS CERTIFICATE DOES NOT AMEND, EXTEND OR ALTER THE COVERAGE AFFORDED BY THE POLICIES BELOW.</b>	
	<b>INSURERS AFFORDING COVERAGE</b>	<b>NAIC #</b>
<b>INSURED</b>  Contractor/Vendor Name Contractor/Vendor Street Address or P.O. Box Contractor/Vendor City, State & Zip Code	INSURER A: Name of Insurance Company	Enter NAIC#
	INSURER B: Name of Insurance Company (if applicable)	Enter NAIC#
	INSURER C: Name of Insurance Company (if applicable)	Enter NAIC#
	INSURER D: Name of Insurance Company (if applicable)	Enter NAIC#
	INSURER E: Name of Insurance Company (if applicable)	Enter NAIC#

### COVERAGES

THE POLICIES OF INSURANCE LISTED BELOW HAVE BEEN ISSUED TO THE INSURED NAMED ABOVE FOR THE POLICY PERIOD INDICATED. NOTWITHSTANDING ANY REQUIREMENT, TERM OR CONDITION OF ANY CONTRACT OR OTHER DOCUMENT WITH RESPECT TO WHICH THIS CERTIFICATE MAY BE ISSUED OR MAY PERTAIN, THE INSURANCE AFFORDED BY THE POLICIES DESCRIBED HEREIN IS SUBJECT TO ALL THE TERMS, EXCLUSIONS AND CONDITIONS OF SUCH POLICIES. AGGREGATE LIMITS SHOWN MAY HAVE BEEN REDUCED BY PAID CLAIMS.

INSR LTR	ADD'L INSRD	TYPE OF INSURANCE	POLICY NUMBER	POLICY EFFECTIVE DATE (MM/DD/YY)	POLICY EXPIRATION DATE (MM/DD/YY)	LIMITS	
A	<input checked="" type="checkbox"/>	<b>GENERAL LIABILITY</b> <input checked="" type="checkbox"/> COMMERCIAL GENERAL LIABILITY <input type="checkbox"/> CLAIMS MADE <input checked="" type="checkbox"/> OCCUR <input checked="" type="checkbox"/> Contractual <input checked="" type="checkbox"/> XCU (explosion, underground, collapse) GEN'L AGGREGATE LIMIT APPLIES PER: <input type="checkbox"/> POLICY <input checked="" type="checkbox"/> PROJECT <input type="checkbox"/> LOC	Enter Policy #	Enter Effective Date	Enter Expiration Date	EACH OCCURENCE	\$1,000,000
						DAMAGE TO RENTED PREMISES (Ea occurrence)	\$100,000
						MED EXP (Any one person)	\$5,000
						PERSONAL & ADV INJURY	\$1,000,000
						GENERAL AGGREGATE	\$1,000,000
						PRODUCTS - COMP/OP AGG	\$1,000,000
						Fire Damage -Any one fire	\$50,000
A	<input type="checkbox"/>	<b>AUTOMOBILE LIABILITY</b> <input type="checkbox"/> ANY AUTO <input type="checkbox"/> ALL OWNED AUTOS <input type="checkbox"/> SCHEDULED AUTOS <input type="checkbox"/> HIRED AUTOS <input type="checkbox"/> NON-OWNED AUTOS <input type="checkbox"/> _____ <input type="checkbox"/> _____	Enter Policy #	Enter Effective Date	Enter Expiration Date	COMBINED SINGLE LIMIT (Each Occurrence)	\$
						BODILY INJURY (Per person)	\$
						BODILY INJURY (Per accident)	\$
						PROPERTY DAMAGE (Per accident)	\$
A	<input type="checkbox"/>	<b>GARAGE LIABILITY</b> <input type="checkbox"/> ANY AUTO <input type="checkbox"/> _____				AUTO ONLY - EA ACCIDENT	\$
						OTHER THAN EA ACC	\$
						AUTO ONLY: AGG	\$
A	<input type="checkbox"/>	<b>EXCESS/UMBRELLA LIABILITY</b> <input type="checkbox"/> OCCUR <input type="checkbox"/> CLAIMS MADE <input type="checkbox"/> DEDUCTIBLE <input type="checkbox"/> RETENTION \$	Enter Policy #	Enter Effective Date	Enter Expiration Date	EACH OCCURENCE	\$
						AGGREGATE	\$
							\$
							\$
							\$
A	<input checked="" type="checkbox"/>	<b>WORKERS COMPENSATION AND EMPLOYERS' LIABILITY</b> ANY PROPRIETOR/PARTNER/EXECUTIVE OFFICER/MEMBER EXCLUDED? If yes, describe under SPECIAL PROVISIONS below	Enter Policy # (Policy must meet statutory requirements)	Enter Effective Date	Enter Expiration Date	<input checked="" type="checkbox"/> WC STATUTORY LIMITS <input type="checkbox"/> OTHER	
						E.L. EACH ACCIDENT	\$1,000,000
						E.L. DISEASE - EA EMPLOYEE	\$1,000,000
						E.L. DISEASE - POLICY LIMIT	\$1,000,000
	<input type="checkbox"/>	<b>OTHER</b>					

### DESCRIPTION OF OPERATIONS / LOCATIONS / VEHICLES / EXCLUSIONS ADDED BY ENDORSEMENT / SPECIAL PROVISIONS

Cherokee County Water And Sewerage Authority is additional insured.

This/These certificate(s) of insurance conform(s) to all terms and conditions (including coverage of the indemnity agreement) contained in Contract with Cherokee County Water And Sewerage Authority.

Insert Contract, Customer Account, and Purchase Order # (Job Description, if Applicable)

### CERTIFICATE HOLDER

Cherokee County Water And Sewerage Authority  
 391 West Main Street  
 Canton, GA 30114

### CANCELLATION

SHOULD ANY OF THE ABOVE DESCRIBED POLICIES BE CANCELLED BEFORE THE EXPIRATION DATE THEREOF, THE INSURER AFFORDING COVERAGE WILL ENDEAVOR TO MAIL 30 DAYS WRITTEN NOTICE TO THE CERTIFICATE HOLDER NAMED TO THE LEFT, BUT FAILURE TO DO SO SHALL IMPOSE NO OBLIGATION OR LIABILITY OF ANY KIND UPON THE INSURER, ITS AGENTS OR REPRESENTATIVES.

AUTHORIZED REPRESENTATIVE

**DETAIL S738**

**COLOR CODES  
FOR  
UTILITY LOCATING**

**RED**      ELECTRIC

**YELLOW**      GAS-OIL

**ORANGE**      TELEPHONE/CATV

**BLUE**      WATER

**GREEN**      SEWER

**IF YOU DIG GEORGIA**

**CALL US FIRST !**

1-800-282-7411

*It's The Law !*

**Utilities Protection Center, Inc.**

**THREE WORKING DAYS  
BEFORE  
YOU DIG GEORGIA  
CALL**

**Utilities Protection  
Center, Inc.**



**1-800-282-7411**

*It's The Law !*

## DETAIL S739 – PAGE 1 of 4

### CHEROKEE COUNTY WATER AND SEWERAGE AUTHORITY SANITARY SEWER SYSTEM CONSTRUCTION GENERAL NOTES

1. All sanitary sewer system construction must follow the current Cherokee County Water and Sewerage Authority Sanitary Sewer System Standards.
2. For D.I.P. sewer lines, the minimum wall thickness shall be Class 50 and the interior lining shall be Protecto 401 ceramic epoxy. Wall thicknesses greater than the minimum called for above may be required due to greater depths or varying bedding requirements. Class C bedding is the minimum allowed.
3. All Polyvinyl Chloride (PVC) sewers 6" to 15" in diameter shall meet the requirements for minimum wall thickness as specified under SDR 35 in ASTM D3034, latest revision. PVC sewers that are 18" and larger in diameter shall have a minimum wall thickness as specified under T-1 in ASTM F679, latest revision. PVC sewers with more than 12' of cover may require wall thicknesses greater than SDR 35 or T-1. PVC is not allowed for sewers greater than 24" in diameter or more than 16' of cover.
4. Ductile Iron Pipe is required for sanitary sewer lines:
  - a. Crossing storm sewers or other utilities with less than 2' of clearance
  - b. Crossing water mains
  - c. Crossing all streams and vegetative buffers
  - d. For all cross country locations with less than 3' of cover
  - e. For all locations in roadways with less than 5' of cover
  - f. For all locations with 16' or more of cover
  - g. With 20% or greater slope
  - h. Inside all casings
  - i. Installed in subdivision easements between lots
  - j. Adjacent to all drop manholes (1 joint minimum at connection to drop manhole)
  - k. For all installations in fill material
  - l. At all other locations designated by the CCWSA
5. Information regarding underground utilities on these plans is not guaranteed as to accuracy or completeness. Prior to beginning work, the Contractor shall request a field location through the utilities protection center and any utility owners thought to have facilities in the area. The Contractor shall promptly compare these field-marked locations with the project plans and then notify the designer of any anticipated problems or need for design changes. It is the Contractor's responsibility to excavate or cause the utility owner to excavate for the purpose of determining exact elevations or locations at utility crossings and other critical locations well in advance of the work under this contract. Damage to existing utilities resulting from the Contractor's negligence shall be repaired at the Contractor's expense. The Developer and/or the Developer's Contractor is responsible for verifying the exact location, size, and material of any existing water or sanitary sewer facility proposed for connection or use by this project.
6. All sewer service laterals shall have a minimum diameter of 6" and a minimum grade of 1%.
7. The Developer shall obtain a land disturbance permit from Cherokee County governing all items related to erosion control.

## DETAIL S739 – PAGE 2 of 4

8. This project is located in Land Lots \_\_\_\_\_, in the \_\_\_\_\_ District of Cherokee County, Georgia.
9. Clearing will be kept to an absolute minimum. Vegetation and mulch will be applied to applicable areas immediately after grading is complete. Land disturbing will be scheduled to limit exposure of bare soils to erosive elements.
10. Construction activities will be performed in compliance with all applicable laws and regulations.
11. All marketable timber will be salvaged. Top soil will be salvaged, stock piled and spread on areas to be vegetated. Trees outside of the clearing line will be protected from damage by appropriate markings.
12. Contractor is responsible for staking the alignment of the proposed pipeline prior to pipe installation. If a conflict should arise, the contractor shall notify the designer at that time.
13. All excavated dirt shall be placed on the high side of the trench away from any creeks.
14. Any fill dirt over the pipe shall be graded to prevent ponding.
15. The right-of-way or construction easement represents the limits of clearing for the complete job. The contractor shall not clear beyond this limit.
16. A copy of the approved construction plans must be kept on the job site at all times that construction is underway.
17. No bury pits are allowed.
18. Topographic ground elevations along all sewer lines, gravity and force mains, are from field-run surveys, not aerial photographs.
19. All easements must be acquired prior to the preconstruction meeting with the Chief Inspector.
20. The Developer/Contractor shall meet with the Chief Inspector at least 24 hours before beginning construction. The Contractor shall notify the Chief Inspector or his designated representative by 8:30 a.m. of each workday when work is scheduled unless authorized otherwise.
21. Sanitary sewer force mains shall be installed so that the top of the pipe is a minimum of four feet below final grade, four feet below the edge of the pavement, or four feet below the ditch paralleling the road, whichever is deepest.
22. Type 4 bedding is required at all restrained pipe installations.
23. Contractor must show proof of insurance in the amount specified by the CCWSA.
24. A horizontal separation of at least 10 feet is required between existing or proposed water mains and existing or proposed sanitary sewer lines.
25. A vertical separation of at least 18 inches is required where a sewer line crosses an existing or proposed water main. A full joint of sanitary sewer pipe is required to be centered at the water main crossing.

## **DETAIL S739 – PAGE 3 of 4**

26. No portion of this project is being constructed on or near an existing landfill, abandoned landfill, or any other site used for waste disposal.
27. Potable water and sanitary sewer structures are not allowed within a dam. Utility pipelines and structures must be a minimum of 30 feet outside the toe of slope of the dam.
28. Existing County roads shall not be open cut unless permission is granted by the Cherokee County Department of Public Transportation.
29. Plan approval is valid for 12 months without beginning construction. Plans shall be subject to beginning the process of review and approval if 12 months expire prior to the start of construction.
30. Record drawings of water and sanitary sewer facilities are required to be submitted to the CCWSA upon completion of the project.
31. If construction plans are stamped for a full project, and then the Developer revises the plans to build the development in phases, no construction or field inspection will be allowed to begin until the revised, phased plans are re-approved and stamped for the phased construction.
32. All streams and protective buffers shall be crossed in accordance with current County and State regulations.
33. Inside of steel casings, pipe joints shall be restrained using Fast-Grip gaskets or approved equal.
34. Safety platforms are required for all manholes that are 16' in depth or more.
35. Concrete footings are required for all manholes that are 16' in depth or more and for all manholes installed in fill material.
36. Sanitary sewers in roadways shall be installed with a minimum of 7' of cover where laterals are located in order to obtain a minimum cover of 5' over the lateral at the R/W limit, or DIP laterals are required.
37. The CCWSA shall not be responsible for any building built too low to be served by the sanitary sewer system.
38. The CCWSA shall not be responsible for any sanitary sewer services covered or buried by construction.
39. Soil adjacent to all manholes located in roadways will be tested for 95% compaction. The CCWSA must receive a copy of the results of the testing before the final plat will be signed.
40. When transitioning from DIP to PVC, the Contractor must utilize solid sleeves or "Harco" fittings.
41. All angles between "in" lines and "out" lines for manholes shall be labeled. Acute angles (angles < 90 degrees) are not allowed for sewer mains or sewer services.
42. Sewer lines that have slopes greater than 20% shall be DIP and shall be provided with concrete anchors (Detail S716).
43. Manholes located in future streets must be installed to be 48" or higher above grade.



**DETAIL S739 – PAGE 4 of 4**

44. Manholes that are located outside of roadways shall be installed to be at least 18" above grade and shall be provided with self-sealing, bolt-down covers.
45. For any new project connecting to an existing manhole, the Contractor shall core and boot the existing manhole at an elevation that is 2 feet or less from the existing invert out.
46. Inside drop manholes shall be 5 feet in diameter and shall be built in accordance with Detail S703.
47. All force mains paralleling water mains shall be encased in green polyethylene tubing so as to identify the force main as sanitary sewer.
48. Inside of developments with curb and gutter, the Contractor shall cut a "S" into the top of the curb above all sanitary sewer service laterals.
49. Locator wire must be installed above all sewer lateral lines.
50. Sanitary sewer cleanouts shall be installed for all service laterals at the edge of the sewer easement or R/W. CCWSA maintenance of laterals ends at the sewer cleanout.
51. Horizontal locations will be referenced to Georgia State Plane Coordinates System (NAD 83 West Zone Feet).
52. Vertical locations will be referenced to North American Vertical Datum (NAVD 88).
53. Orthometric locations will be referenced to GEOID 99/03.
54. No landscaping or structures will be allowed in CCWSA easements.

**Return to:**  
Cherokee County Water & Sewerage Authority  
1957 Authority Drive  
Woodstock, Georgia 30189  
Attn: Jeffery Hooper  
**State of Georgia**  
**County of Cherokee**

**Grant of Easement**  
**Sewer Line/Main**

This grant of easement made this \_\_\_\_\_ day of \_\_\_\_\_, 20\_\_\_\_\_, from \_\_\_\_\_ of the State of Georgia, and County aforesaid, hereinafter called Grantor, to **CHEROKEE COUTY WATER AND SEWERAGE AUTHORITY**, a Political Subdivision of the State of Georgia, herein called the Grantee.

**WITNESSETH**, the Grantor for and in consideration of the sum of \$1.00 and other valuable considerations in hand paid, at and before the sealing and delivery of these presents, does grant bargain, sell, and convey unto Grantee an easement and perpetual right-of-way over, upon, through, under and/or across the property of the Grantor in Land Lot \_\_\_\_\_, of \_\_\_\_\_ District, 2<sup>nd</sup> Section, Cherokee County, Georgia, and being a strip of land more particularly described and shown on the plat attached hereto as Exhibit "A" and entitled \_\_\_\_\_ (Subdivision Name, Phase, Unit, and or Pod, \_\_\_\_\_ Lot Number \_\_\_\_\_) made a part hereof showing the dimensions and location of this easement. The permanent easement covered by this instrument is \_\_\_\_\_ feet wide, with the permission to use an additional \_\_\_\_\_ feet wide during construction. The easement begins and ends where the said pipeline enters and leaves the property line as indicated above, and totals approximately \_\_\_\_\_ feet in length.

The easement covered by this instrument is for the purpose of a sanitary sewer line/main and utility installation together with the right to go upon said land to install said water line and installations with the continuous right from time to time to go in and upon said right of way and to construct, install, operate, maintain, inspect, reconstruct, repair, renew, and replace therein the pipeline and other installations as may be necessary; also the right to clear, keep clear, remove and dispose of all undergrowth, trees and other obstructions, objects and structures on said right of way, which are inconsistent with the rights of the Grantee and which may interfere with or endanger the construction, operation and maintenance of said sewer line/main and other installations; also the right of ingress and egress to and from said right of way over roads, if any, existing at the time for such ingress and egress, for the purpose of constructing, operating, maintaining, repairing, renewing, replacing said sewer line/main and installations. Said right of way easement may be used by the owners of said land, or their assigns, provided such use is not inconsistent with the rights sought to be condemned and further that such use does not interfere with, injure or endanger said sewer line/main and other installations and the construction, repairing, renewal and replacement thereof and the uses for the purposes hereinbefore stated.

The Grantor does hereby covenant that they are lawfully seized and possessed of the real estate above described, that Grantor does have good and lawful right to convey the said property, and said property is free from all encumbrances, and that they will forever warrant and defend title thereto against the lawful claims of all persons whomsoever.

IN WITNESS WHEREOF, said GRANTOR hereunder set his hand and affixed his seal on the date written above.

**WITNESS**

**GRANTOR(S)**

\_\_\_\_\_  
Witness (printed name)

\_\_\_\_\_  
Grantor (printed name)

\_\_\_\_\_  
Witness (Signature)

\_\_\_\_\_  
Grantor (Signature)

\_\_\_\_\_  
Grantor (Printed Name)

\_\_\_\_\_  
Grantor (Signature)

**CCWSA ACCEPTANCE**

Sworn to and subscribed before me  
this the \_\_\_ day of \_\_\_\_\_ 20 \_\_\_\_.

\_\_\_\_\_  
CCWSA Representative (Printed Name)

\_\_\_\_\_  
Notary Public (SEAL)

\_\_\_\_\_  
CCWSA Representative (Signature)